

Zetasizer μ V User Manual

MAN0428 Issue 1.0 December 2008

© **Malvern Instruments Ltd. 2003, 2004, 2006, 2007, 2008**

Malvern[®] Instruments makes every effort to ensure that this document is correct. However, due to Malvern Instruments' policy of continual product development we are unable to guarantee the accuracy of this, or any other document after the date of publication. We therefore disclaim all liability for any changes, errors or omissions after the date of publication. No reproduction or transmission of any part of this publication is allowed without the express written permission of Malvern Instruments Ltd.

Head office:

Malvern Instruments Ltd.
Enigma Business Park,
Groveswood Road,
Malvern,
Worcestershire WR14 1XZ
United Kingdom.

Tel + [44] (0)1684-892456
Fax + [44] (0)1684-892789

**Zetasizer is a registered trademark in the UK and/or other countries, and is owned by Malvern Instruments Ltd.
Malvern and the green "hills" logo are registered trademarks in the UK and/or other countries, and is owned by Malvern Instruments Ltd.**

Windows 2000 and XP are registered trademarks of the Microsoft Corporation.
Zetasizer, NIBS and M3-PALS are registered trademarks of Malvern Instruments.
Tygon is a registered trademark of Cole Palmer Instruments Company Limited.

Printed in England

Addendum to manual

Addendum number	ADD0076-1.0
Date	04/02/2009
Manual number	MAN0428-1.0
Manual name	Zetasizer μ V User Manual

This addendum presents new information for taking measurements at ambient temperatures while using the Flow-mode facility on the Zetasizer μ V instrument.

The information below should be inserted as a third paragraph in the **Sample - Temperature** section on page 9.16, and as a fifth paragraph in the **Flow-mode SOPs** section on page 9.33.



Note

To improve the stability of temperature control when using the system as a Gel Permeation Chromatography (GPC) detector, the measurement temperature should be set to be 5°C or greater, above or below the ambient temperature.

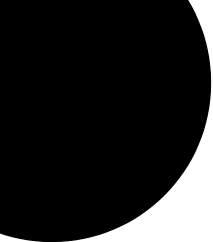

Table of contents

Part 1 - Operator's Guide

Introduction to this manual

Introduction	1-1
How to use this manual	1-1
Access to the instrument	1-3
Assumed information	1-3
Where to get help.	1-4

What is the Zetasizer μ V?

Introduction	2-1
What does the Zetasizer μ V do?	2-1
What are Particle Size and Molecular weight?	2-2

How does the Zetasizer μ V work?

Introduction	3-1
How is a Zetasizer measurement performed?	3-2
What does the Zetasizer consist of? - Identifying the hardware	3-5
Navigating the software	3-11

A Tutorial - Making a measurement

Introduction	4-1
Quick guide to making a measurement	4-2
Powering up the system	4-2
Sample preparation	4-3
Choosing the correct cell	4-3
Filling the cell.	4-7
Inserting the cell.	4-9
Making an SOP measurement	4-11
Making a manual measurement.	4-13

The Measurement display	4-13
-----------------------------------	------

Records and Reports - Viewing the Results

Introduction	5-1
Displaying the results	5-1

Sample Preparation

Introduction	6-1
Preparing the sample - Size	6-1
Preparing the sample - Molecular weight	6-2
Count rate meter	6-4

Part 2 - Supervisor's Guide

Security

Introduction	7-1
Initial start-up - set up the administrator.	7-2
Enabling security	7-3
User groups.	7-4
Users	7-5

Measurement file window - Workspaces

Introduction	8-1
Measurement file window	8-2

Using SOPs

Introduction	9-1
The SOP Editor	9-3
Creating an SOP	9-8
Measurement type selection	9-9
Size SOPs	9-10
Molecular weight SOPs	9-25
Flow-mode SOPs.	9-33
Trend SOPs	9-35

Extracting an SOP	9-37
Modifying an SOP	9-38
Distributing an SOP	9-38

Advanced features

Introduction	10-1
Solvent Builder.	10-2
SOP Player	10-4
Result averaging	10-9
Editing the result	10-10
Exporting results	10-12
Flow-mode	10-16
Options dialogue	10-21
Expert Advice	10-25

Creating Custom Reports

Introduction	11-1
Overview	11-2
Opening an existing report	11-3
Creating a new report	11-3
Adding elements to the report	11-4
Setting up the report elements	11-5
Selecting elements	11-13
Aligning and sizing elements	11-14
Saving a report.	11-14
A finished report.	11-15
Viewing the new report	11-15
Other information shown on a report	11-16
Protecting a report	11-16

Protein Utilities

Introduction	12-1
Debye plot.	12-2
Molecular weight calculations	12-7
Concentration utilities.	12-10

Scattering functions	12-11
--------------------------------	-------

Size theory

Introduction	13-1
What is Dynamic Light Scattering?	13-1
Operation of the Zetasizer μ V - Size measurements	13-6

Molecular Weight theory

Introduction	14-1
What is Static light scattering?	14-1
The Debye plot.	14-4

Part 3 - Appendices

Specification

Specification	A-1
Chemical compatibility	A-2

Unpacking instructions

Installation

Introduction	C-1
Installing the Zetasizer μ V	C-2
Changing the computer	C-2

Regulatory Statements

Disposal of Electrical & Electronic Equipment	D-1
FCC Notice (US only)	D-2
Canadian Regulatory Information.	D-3
VCCI acceptance (Japan only).	D-3

Part 1 -

Operator's Guide

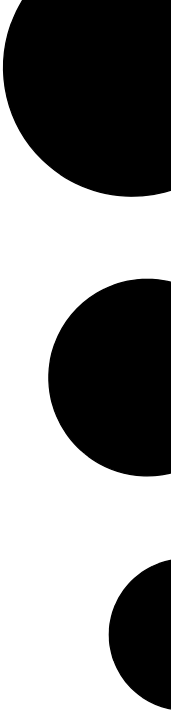

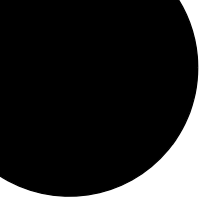

Introduction to this manual

Introduction

This manual covers the operation and maintenance of the Zetasizer μV particle analyser.



Note

The Zetasizer model, Serial number, software and firmware version can be found by left-clicking the μV icon in the right corner of the status bar.

The aim of this manual is to:

- Identify what the instrument is.
- Explain in simple terms how it works.
- Explain how the instrument should be used to make a measurement.
- Identify the user maintenance procedures.

How to use this manual

Read this manual together with the **Essentials manual**, which describes Site Requirements, Health and Safety and Maintenance information.



Warning!

The instrument and the samples to be measured may be hazardous if mis-used. Users must read the **Health and Safety** information in the **Essentials manual** before operating the system.

We recommend reading both these manuals fully before starting the first measurement, though if more familiar with particle size analysers, jump straight to **Chapter 4**. This chapter gives practical details on making measurements.

This manual is divided into three sections as follows.

Part 1 – Operator’s guide

This guide and the **Essentials manual** contain all the information required for the operator to use the Zetasizer μV instrument.

Topics covered are: What is the Zetasizer μV instrument, what are the components of the Zetasizer μV , what it does, instructions on using the instrument and the software, basic measurement and maintenance procedures.

Part 2 – Supervisor’s guide

The Supervisor’s guide concentrates on the administration of the Zetasizer μV and covers some of the more advanced features. It also provides a greater insight into the measurement procedures and expands on the analysis theories.

Topics covered are: security aspects, use of **Standard Operating Procedures (SOPs)**, organising measurement files and discussion on the analysis theories used – Size and Molecular weight.

It is recommended that the supervisor should also read Part 1 – Operator’s guide.

Part 3 - Appendices

This contains supplementary information not necessary for the general operation of the system.

More detail on the Zetasizer software can be found by using the on-line **Help** within the software.

Access to the instrument

Within this manual, reference is made to the various people who will have access to the instrument.

Malvern personnel

Malvern personnel (service engineers, representatives, etc.) have full access to the instrument and are the only people authorised to perform all service procedures that may require the removal of the covers.



Warning!

Removal of the main covers by unauthorised personnel, even a supervisor, will invalidate the warranty of the instrument.

Supervisor

The supervisor is responsible for the management and safety of the instrument and its operation. The supervisor also trains the operators. They can perform all user maintenance routines identified in the **Essentials manual**.

Under no circumstances, should the supervisor remove the main cover of the instrument.

Operator

An operator is a person trained in the use of the system. The operator can perform all user maintenance routines identified in the **Essentials manual**, except changing the fuse.

Under no circumstances, should the operator remove the main cover of the instrument.



Warning!

Failure to follow these guidelines could result in exposure to hazardous voltages and laser radiation.

Assumed information

Naming convention

The Zetasizer μV will either be referred to in full, or as “the instrument”.

The combination of the Zetasizer μV instrument, the computer and Zetasizer software may be referred to as the “the system”.

Cells and Cuvettes

Any device for holding and measuring the sample in the instrument will generally be referred to as a “cell”. This includes dip cells and all kinds of cuvettes used (i.e. glass, small volume, disposable) unless a proper description is more appropriate.

Solvents and dispersants

To reflect the intended protein analysis applications of the system, the term “solvent” is used throughout this manual to refer to any fluid used to disperse a sample’s particles for measurement. However, solvent can also be taken to mean “dispersant” where this is more applicable to the sample type.

Menu commands

Menu commands from the Zetasizer software are referred to in the form **main menu-menu item**. As an example, the command **Tools-Options** refers to selecting the **Options** item in the **Tools** menu. Menu commands are shown in bold text.

Where to get help

Manuals and Help files

The primary sources of help for the Zetasizer μV are the **Essentials manual**, this manual and the on-line help system within the software. This manual is designed to give an overview of the system as a whole, while the on-line help system is designed to give detailed information on the Zetasizer software.

Each dialogue within the Zetasizer software has a **Help** button that gives information specific to that dialogue.

Essentials Manual

This manual covers:

- **Site requirements** – all the physical requirements for positioning the system. Information is given on; services requirements (air, water, number of power sockets, etc.), environmental requirements (temperature, humidity etc.) and physical requirements (space requirements etc.).
- **Health and safety** – this **must** be read by all users of the system. It details all safety issues for the optical unit and all accessories.

- **Maintenance** – for both the optical unit and accessories.

Help desk

All queries regarding the system should initially be directed to the local Malvern representative. Please quote the following information:

- Model and serial number of the instrument (located on the rear panel).
- The Zetasizer software version (select **Help-About** within the software).

Contact the United Kingdom help desk if the local Malvern representative is not available. The direct line to the United Kingdom Helpdesk is +44 (0) 1684 891800. This help line is primarily English speaking.

Remote support

Malvern Instruments offers a remote support service over the Internet. Benefits include fast and efficient fault diagnosis, reducing downtime and costs.

On-line user training is also available, plus software updates. A direct Internet connection must be available to make use of this facility.

Malvern Website - www.Malvern.com

The Malvern website offers a comprehensive range of particle characterisation resources for use by customers 24 hours a day, seven days a week.

Resources include software downloads, frequently asked questions, a knowledge base and application notes, plus information on other particle characterisation solutions that Malvern can provide.

What is the Zetasizer μV ?

Introduction

This chapter gives a brief overview of the Zetasizer μV instrument and simple explanations about the measurement technique.

What does the Zetasizer μV do?

The Zetasizer μV instrument provides the ability to measure two characteristics of particles or molecules in a liquid medium.

These fundamental parameters are **Particle size** and **Molecular weight**. By using the unique technology within the Zetasizer μV , these parameters can be measured over a wide range of concentrations. The Zetasizer μV also has the ability to perform **Trend** measurements, including the determination of the **Protein melting point**.

The Zetasizer μV features pre-aligned optics, plus the precise temperature control necessary for reproducible, repeatable and accurate measurements. In addition, the facility is included for measurements of other key parameters such as concentration.

The Zetasizer range has been designed with simplicity in mind, so that a minimal amount of user interaction is necessary to achieve excellent results. The use of Standard Operating Procedures (SOPs) alleviate the need for constant attention.

The Zetasizer μV measurement range

The Zetasizer μV measurement specifications are described below:

- **Size range radius:** 0.3nm to 0.5 μm
- **Molecular weight range:** 380Da to > 20MDa

What are Particle Size and Molecular weight?

This section describes the basics of Particle Size and Molecular weight are and why they are important. Greater detail on the instrument's measurement techniques is given in the chapters that cover theory (**Chapter 13** and **Chapter 14**).

What is Size?

The Particle Size measured in a DLS instrument is the diameter or radius of the sphere that diffuses at the same speed as the particle being measured.

The Zetasizer μV determines the **size** by first measuring the **Brownian motion** of the particles in a sample using **Dynamic Light Scattering (DLS)** and then interpreting a size from this using established theories - see **Chapter 13**.

Brownian motion is defined as:

“The random movement of particles or molecules in a liquid due to the bombardment by the solvent molecules that surround them”.

The particles in a liquid move about randomly and their speed of movement is used to determine the size of the particle or molecule.

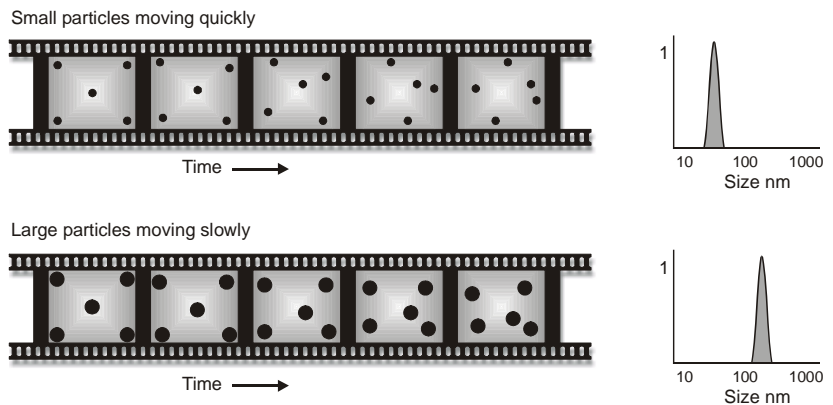

ill 6722

It is known that small particles move quickly in a liquid and large particles move slowly. This movement is carrying on all the time, so if we take two ‘pictures’ of the sample separated by a short interval of time, say $100\mu S$, we can see how much the particle has moved and therefore work out how big it is.

If there has been a minimal movement and the particle positions are very similar, then the particles in the sample will be large; similarly if there has been a large amount of movement and the particle positions are quite different, then the particles in the sample are small.

Using this knowledge and the relationship between diffusion speed and size, the size can be determined.

The above is a **very** simplistic explanation. A more detailed explanation can be found in **Chapter 13**.

What is Molecular weight?

The Molecular weight of a substance is the weight in **atomic mass units (amu)** of all the atoms in one molecule of that substance. Mathematically the **molecular weight** can be calculated from the **molecular formula** of the substance; it being the **sum** of the **atomic weights** of all the atoms making up the molecule.

If we take as an example the molecular formula H_2O (water) we can work out the molecular weight.

- In each molecule of water there are two atoms of hydrogen (H_2) and one atom of oxygen (O).

Now the atomic weight of hydrogen is 1.008 amu and that of oxygen is 15.999.

Therefore the Molecular weight of water is 18.015 i.e. $(1.008 \times 2) + 15.999$.

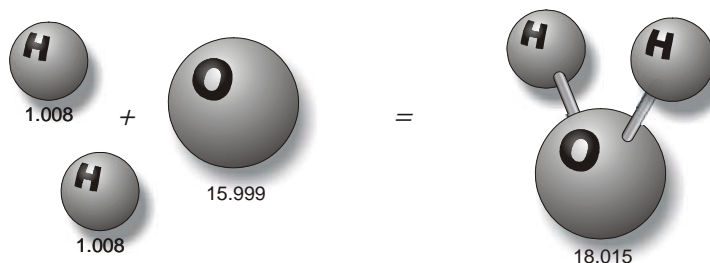

This is a calculation using a known molecular formula and applying the values from the periodic table. iii 6721

With the Zetasizer μ V instrument, the molecular weight can now be determined by use of **Static Light Scattering (SLS)** measurement techniques.

This technique is explained in **Chapter 14**.



Note

Malvern uses **Daltons** as the unit of molecular weight. Results are displayed in kiloDaltons (kDa).

Why do we want to know it?

We need to know the molecular weight, so we can determine how many grams there are in 1 mole of a substance. The mole is the chemistry standard term for '1 molecular weight', e.g. one mole of water is 18.015g.

How does the Zetasizer μ V work?

Introduction

Previously we identified the instrument and described the various measurement processes that can be performed. This chapter introduces the hardware and software features that the instrument incorporates.

The initial section, “How is a Zetasizer measurement performed?”, will briefly describe the following:

- What is involved in making a measurement?
- What are the major components of the system?
- How the software performs the task?

This is followed by two sections identifying the major hardware components and the software used.

The complete measurement process for size and molecular weight measurements will be described in later chapters.

How is a Zetasizer measurement performed?

The Zetasizer system comprises the Zetasizer instrument ① and a computer with the Zetasizer software installed ④. A cell ③ is filled with the sample and loaded into the cell area on the top of the instrument ②.

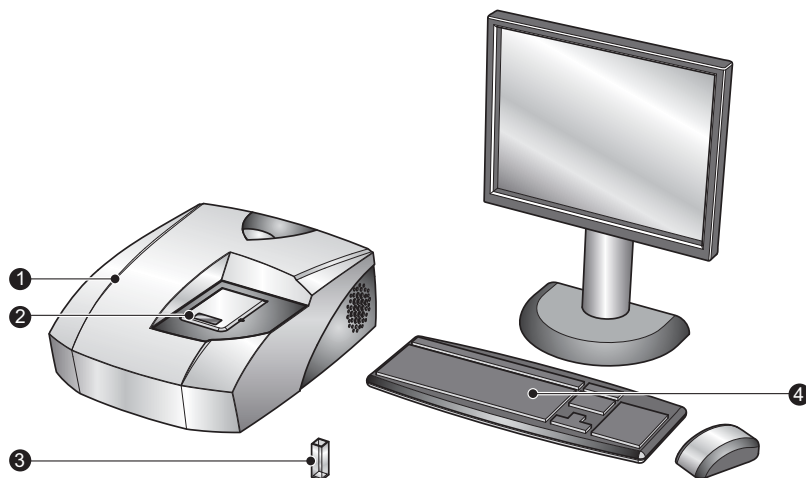

ill 6744

The software is used to control the measurement of the sample, there are two basic ways to make a measurement:

- **SOP measurements.** A **Standard Operating Procedure (SOP)** is like a template that pre-defines all the measurement settings. This ensures that measurements made on the same type of sample are made in a consistent way. SOPs reduce the requirement for repetitive user input and the risk of introducing errors. SOPs can be created or modified as required.

To perform an SOP measurement, select **Measure-Start SOP** from the menu bar and select an SOP to use. With an SOP chosen the **Measurement display** will appear (see below). The measurement is begun by pressing the **Start**  button.

- **Manual Measurement.** A manual measurement is where all the measurement parameters are set immediately before the measurement is performed. This is ideal if measuring many different types of sample, or experimenting with the measurement parameters.

To perform a manual measurement, select **Measure-Manual** from the menu bar. A manual measurement dialogue window will appear where the measurement settings can be chosen, and if required saved as an SOP. After choosing these, begin the measurement by simply pressing the **Start**  button on the **Measurement display** (below).

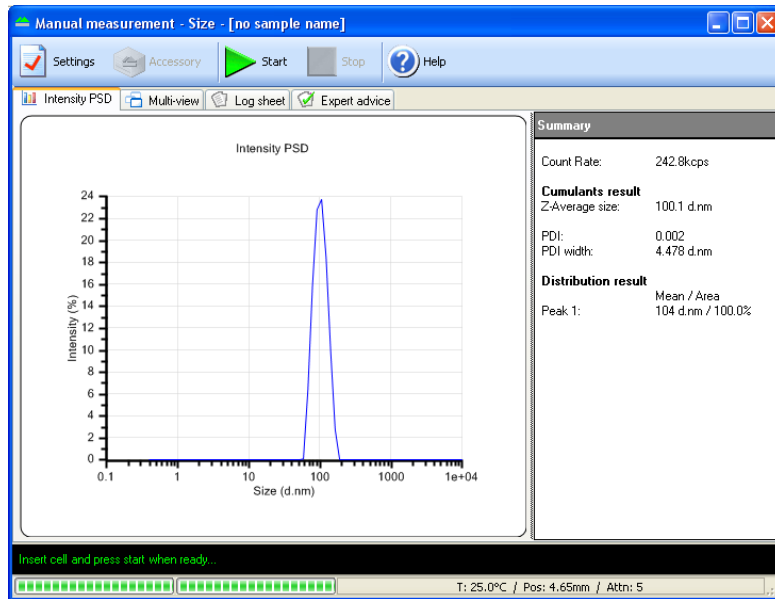

Once the measurement is complete the results can be viewed; either in a **Record view** ①, by selecting one of the Malvern pre-set reports ②, or a user defined report ③.

The screenshot displays the Zetasizer software interface with the following components:

- Callout 1:** Points to a table of measurement records. The table has columns for Record, Type, Sample Name, Measurement Date and Time, T, Z-Ave, Pd, Aggregation Index, ZP, Mw, Mw/Mn, and Z-average. Record 7 is highlighted.
- Callout 2:** Points to the summary parameters section, including:
 - Temperature (°C): 25.0
 - Count Rate (kcps): 21687.7
 - Cell Description: Disposable sizing cuvette
 - Duration Used (s): 10
 - Measurement Position (mm): 4.85
 - Attenuation: 0
 - Z-Average (d.nm): 107.7
 - Pd: 0.548
 - Intercept: 0.257
 - Result quality: Refer to quality report
- Callout 3:** Points to the 'Size Distribution by Intensity' graph, which shows a plot of Intensity (%) versus Size (d.nm) on a logarithmic scale.
- Right Panel:** Shows 'Independent Analysis' results for 'user defined report', including experimental parameters and a table of moments:

Sample Name:	File Name:	Record Number:	Concitant	Multi
test 2.dts	test 2.dts	7		
Mean (d.nm):	107.7	210.2		
Mode (d.nm):	—	216.0		
Polydispersity Index:	0.548	—		
Polydispersity [SD] (d.nm):	79.76	150.4		
%Polydispersity:	74.0	71.2		
Intensity (%)	—	98.4		
Mass (%)	—	0.1		
MW - Globular Protein (kDa):	3.78e4	1.97e5		
MW - Linear Polymer (kDa):	2.900	1.07e4		
MW - Branch Polymer (kDa):	1.57e4	7.61e4		
MW - Starburst Poly (kDa):	4.34e5	4.64e6		

ill 8300

The measurement results will be automatically saved to a measurement file.



Note

The measurement file must be selected **before** the measurement is started as the measurements will be saved in the file currently open.

What does the Zetasizer consist of? - Identifying the hardware

The diagram below shows a typical system with its key modules, the Zetasizer instrument and a computer system with the Zetasizer software installed. It is preferable the computer is dedicated to just running the Zetasizer software.

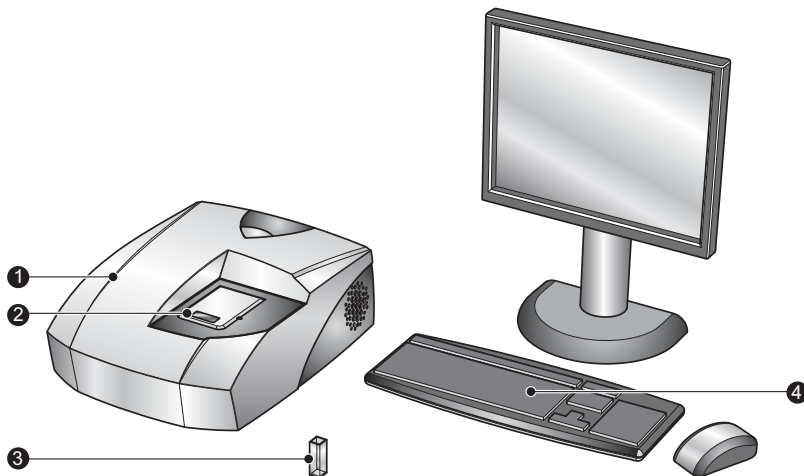

i11 8306

The software controls the Zetasizer and any accessories used and analyses the data from the instrument to give either the size or molecular weight for the sample measured.

The Zetasizer μ V instrument

① Optical unit

Positioned on the cover is a label that identifies the instrument model.

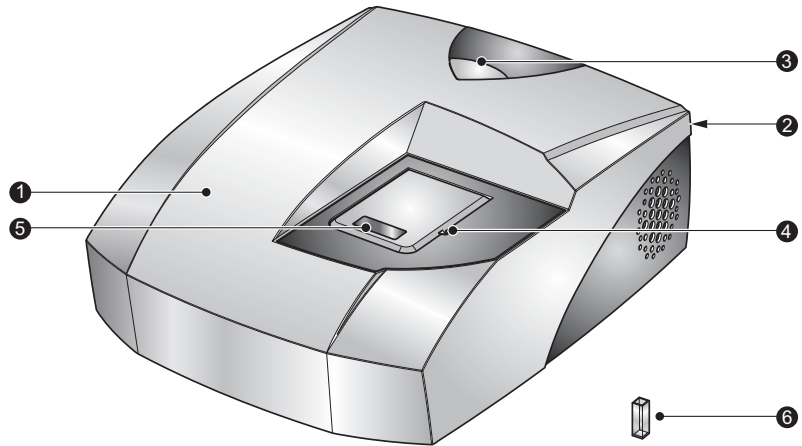

ill 8307

② Rear Panel

The rear panel provides all the connections. These are identified below.

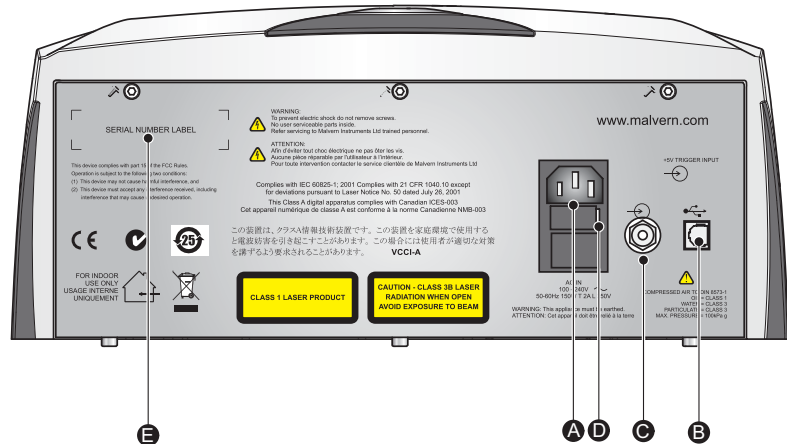

ill 8308

A Power input socket

Mains power input socket for the instrument.

B Computer connection

The **USB** cable from the computer is connected here.

© Purge connection

If measuring samples at low temperatures there is a risk of condensation occurring on the cell; this occurs when the measurement temperature is less than the 'dew point' of the ambient air surrounding the cell. This is particularly likely in humid climates. If it is suspected that this may be a problem then the purge inlet port can be used to connect a dry-air supply - i.e. a supply with a dew point below that of the target temperature. This will remove any moisture in the air immediately surrounding the cell and prevent condensation.

If using the purge inlet connector then the air supply must conform to the following specification:

- Compressed air to DIN 8573-1
- Oil = Class 1
- Water = Class 3
- Particulate = Class 3
- Pressure = 100 kPa g

For connection purposes, the purge input uses a push-fit connector.

An optional **purge connection kit** is available from Malvern instruments if this facility is to be used.

When performing a purge measurement the following rules should be taken into account:

- The flow rate will be preset at 1.5ltr/min at 1 bar.
- The instrument should be operated at a maximum of 30°C & 70% relative humidity when the requested temperature is below the dew point.
- When operating at a humidity higher than 50%, the measurement should allow a minimum delay of 4 minutes to allow the temperature to stabilise.

**Caution!**

It is important that the purge air line supply conforms to the above specification. Failure to meet this specification may result in permanent damage and invalidation of the warranty.

ⓓ Power switch

The on/off power switch for the instrument. When switched on, the blue **power indicator** ⓓ will illuminate.

**Warning!**

Do not obstruct the ventilation slots underneath the instrument, nor the fans on the rear panel.

⑤ Serial number and Model number label

Identifies the actual Zetasizer μV model and its serial number. Please quote all numbers in any correspondence with Malvern Instruments.

③ Power light

Illuminates blue when the system is powered on.

④ Flow mode tubing outlet

A channel in the cell area lid provides the option to connect flow cell tubing. See **Chapter 10** for more information on flow mode.

⑤ Cell area**Warning!**

The system is capable of heating the cell to high temperatures. Care should be taken when removing the cells if a measurement has been performed at high temperatures. It is recommended that the cell area is allowed to cool before removing the cell.

A **warning triangle** is provided in the cell basin.

The cell area is where all cells are inserted to undertake a measurement. The cell area is completely self enclosed and controls the sample temperature over the range 2°C to 90°C.

**Note**

When the Zetasizer is initially switched on the cell area will be driven to a “default” temperature of 25°C. This will also happen if the software is closed, but the instrument is not switched off.

Chemical compatibility

Apart from the measurement cells, the only part of the instrument that should come into contact with any sample is the cell area if spillage occurs. The cell area has been manufactured from materials that are considered to give the widest protection from chemical attack. However, it is important to check that any sample used is chemically compatible with the materials from which the cell area is manufactured.

Refer to **Appendix A** for a list of the cell area components that may come into contact with any spilt sample.

Features of the cell area

Other important features of the cell area are described below.

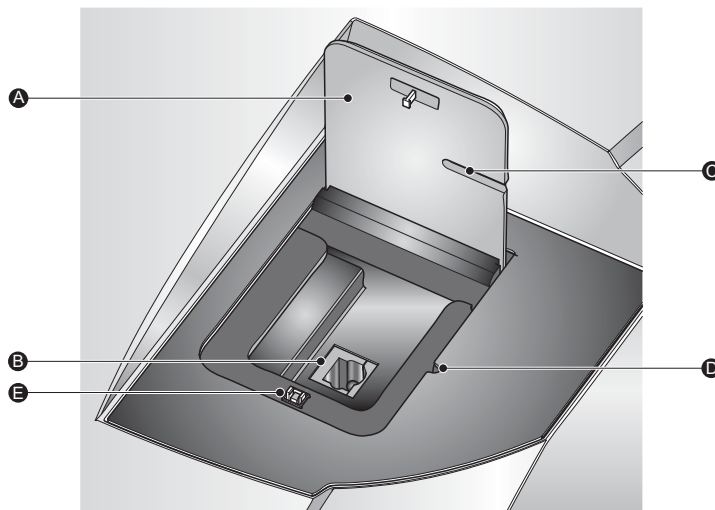

i18310

Ⓐ Cell area lid

Press down on top of the cell area lid (where it is marked “Push”) to unlock the catch, and then release. The lid will rise to an upright, open position allowing access to the cell holder.

- **Laser safety interlock.** This is activated on opening the cell area lid and prevents any laser light from entering into the cell area.

To close the lid push it down until it locks. No measurements can be performed unless the lid is fully closed.



Note

The software will indicate if the wrong cell has been inserted for the measurement.

Ⓑ Cell basin

The cell basin is made of an insulating material which provides protection from the heated cell holder.

A warning label indicates that high temperatures may exist in the cell area.

© **Flow tube channel**

Channel provides access for a tube when an optional flow cell is connected.

© **Flow tube notch**

Notch provides access for a tube when an optional flow cell is connected.

© **Cell lid catch**

Mechanism to keep the cell closed during a measurement.



Note

It is recommended that when using glass or quartz cuvettes, to first insert a disposable polystyrene cuvette into the cell holder. This is done to ensure the cell clamp moves freely, and that no spilt sample has caused the mechanism to stick.



Note

The Zetasizer μV model, serial number, software and firmware version can be found by double-clicking the μV icon in the right corner of the status bar.

⑥ **Cells and Cuvettes**

A range of cells and cuvettes are available to use with the Zetasizer instrument. Full details are given in the **Chapter 4**, but briefly the following cells can be used.

Cell	Application
Disposable “polystyrene” cuvettes – Standard and Small volume	Size
Quartz glass cuvettes – Square, Standard, Low and ultra-low volume, flow	Size and Molecular weight

Navigating the software

The Malvern Zetasizer software controls the system during a measurement and then processes the measurement data to produce either a size or Molecular weight result. It displays the results and allows reports to be printed.

There are two software modules:

- The main Zetasizer application which is described below
- A secondary module known as Report Designer which enables custom reports to be created to display the results. The features of Report Designer are detailed in **Chapter 11**.

The next section describes the key features of the main application.

The Zetasizer software application

A typical screen is shown below. The features and their function are described in the following sections.

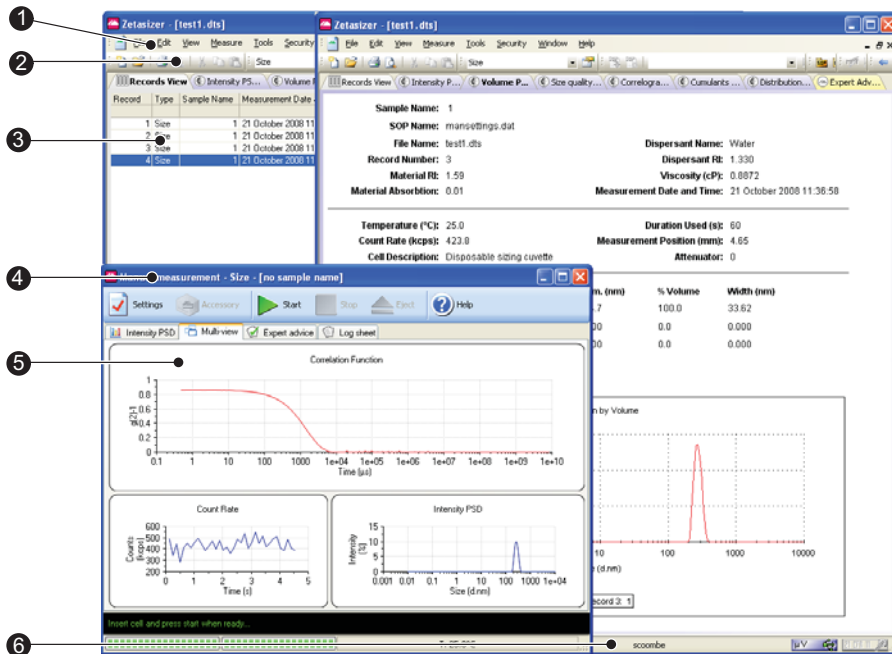

① Menu bar

The menu bar contains the main menu headings for all software functions.

Items which end with a row of dots (...) will cause dialogue boxes to appear. Similarly any items which end with an arrow (▶) will cause a second menu to appear.

Items that are shown in grey are not available. Grey items indicate that some security setting has been activated, or that the item is not relevant to the system connected.

The Menus available are shown below, together with a brief overview.

File Menu

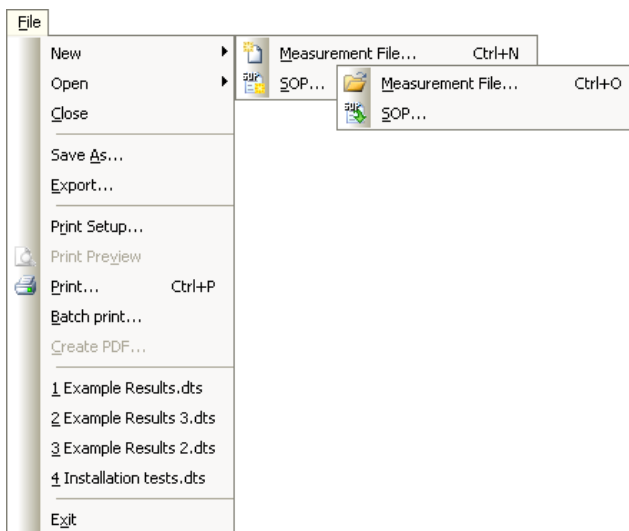

The **File** menu can be used to either create a **New** Measurement or SOP file, or **Open...** an existing Measurement or SOP file.

- The **Measurement file** is where all the measurement records (results) will be stored.
Select **Save as...** to store a measurement file under a different file name.
- An **SOP file** contains all the measurement settings required for performing repetitive and consistent measurements.

Once a measurement file has been created, use **Export...** to export the measurement details to other software packages such as Excel or Wordpad.

Select **Batch print...** to simultaneously print a number of measurement records.

Create PDF... is only enabled if the 21 CFR part 11 feature key has been installed.

As a shortcut, a list of the most recently used measurement files are shown at the bottom of the menu for immediate opening.

Exit will close down the software.

Edit Menu

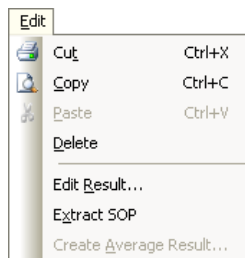

This allows movement and manipulation of records in the Measurement file window(s). Records can be **cut**, **copied**, **pasted** and **deleted** into their own or other measurement files.

Edit result... allows an existing measurement record to be reanalysed using different solvent and particle properties. Comments on the editing reason can be added. The edited measurement will then be added to the bottom of the Records view listing.

To view the settings for any particular measurement record, select the record and then **Extract SOP...** The **SOP editor** dialogues will appear showing the original measurement settings. These can then be saved as an SOP so measurements can be made again with the same settings. This is useful if the parameters of the measurement record are not already saved in the SOP directory.

Create Average Result, enables a number of records to be selected, then recalculated to show the average result. The averaged result is added to the bottom of the record view.



Note

A combination of the **Edit** and **View** menus will appear when the right mouse button is pressed anywhere in the measurement file window.

View Menu

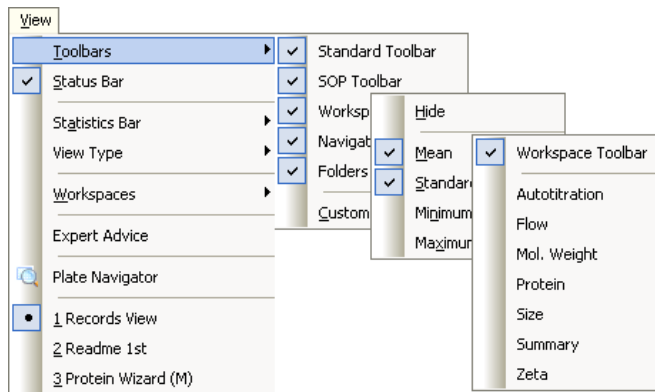

The **View** menu allows the selection of which reports will be shown in the measurement file window and those **Toolbars** to be displayed.

To see the Standard deviation, the Relative standard deviation, the minimum, the maximum or the mean of a selected number of records, a **Statistics bar** can be displayed.

Additionally **View type** will display the Melting point in either a Sorted or Outlined format.

Workspaces will select the workspace toolbar, and which measurement workspace is to be displayed.

The reports available are those selected when creating the workspace with the **Configure-Workspace** dialogues. The reports available will change to match the workspace chosen.

All currently available reports are shown at the base of the menu. The icon indicates the report that is currently displayed.

Select **Status bar** to toggle the status bar from being displayed or not.

Expert Advice enables a quality check to be performed on three or more completed measurement records. This will show how good the measurements are and whether they display any unwanted attributes, such as aggregation. The Expert advice is also available directly from the records view, and during a measurement sequence in the measurement display. Refer to the Expert Advice section for a description.

Plate Navigator provides a graphical view of measurements made using a Zetasizer APS instrument. Greyed out for results made on the Zetasizer μV .

**Note**

A combination of the **Edit** and **View** menus will appear when the right mouse button is clicked anywhere in the measurement file window.

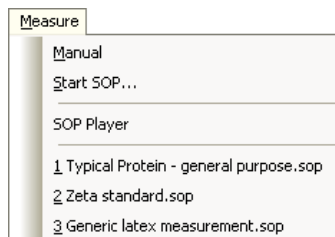
Measure Menu

Select this menu when ready to perform a measurement.

There is a choice of using an existing measurement SOP (**Measure-Start SOP...**) or manually setting up the measurement and sample details (**Measure-Manual**).

Once the measurement details have been entered or an SOP has been chosen, the **Measurement display** will appear.

The most recent SOPs used are displayed at the base of the menu.

SOP Player opens the SOP Player program; this enables a sequence of SOPs and other actions to be performed sequentially. See the SOP Player section for a description.

Tools Menu

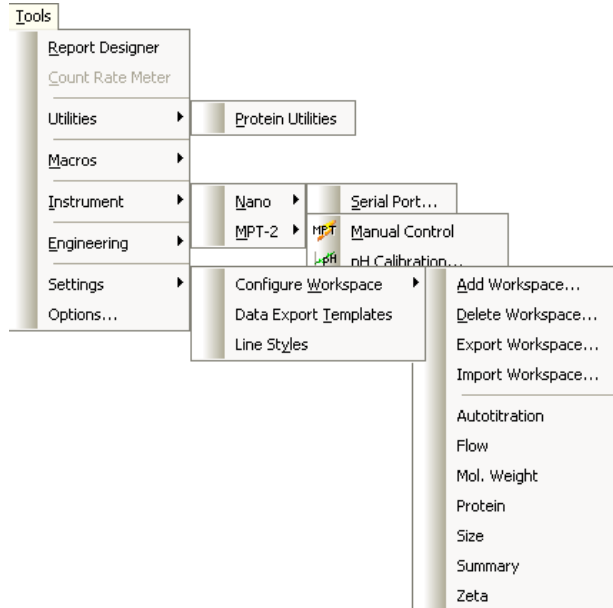

The operation of **Report Designer** is explained in **Chapter 11**.

The **Utilities-Protein** option is described in **Chapter 12**. With this tool, estimates of the Molecular weight and particle shape can be generated.

The **Count Rate Meter** displays the number of photons detected per second. This is useful for determining both the sample quality and concentration. Refer to the Count rate meter section at the end of **Chapter 6**.

The **Macros** submenu will show additional available programs. These are programs written by Malvern to enable the system to operate in a mode required for a specific application. These can be installed and selected using the **Options** feature.

The **Instrument** Sub-menu allows access to the manual controls of the instrument or each connected accessory.

- **Serial port...** allows the USB communications port to which the instrument is connected to be chosen. This menu item is greyed out - available only on the Zetasizer Nano series.

Engineering allows Malvern authorised service engineers to perform maintenance tasks. The engineering functions are password protected.

The **Settings** sub-menu provides access to the **Configure Workspace**, **Data export templates** and **Line styles** options.

- The reports available, and the parameters shown in the **Records view** tab, are those selected when creating the measurement file workspace with the **Work-space...** dialogues. The dialogues enable workspaces to be **deleted** and **Added**, workspaces to be **imported** or **exported**, and previously created workspaces to be displayed.
- **Data Export Templates...** opens a dialogue that defines the parameters and the format in which the record data will be exported. Once a template is created the measurement data can be exported to other software packages such as Excel or Wordpad, by using **File-Export data**.
- **Line styles...** allows the colour and style of lines to be changed in the report graphs.

Options opens a dialogue that allows the following options to be selected:

- **Startup** - Allows the user to specify how the software behaves on startup. Select the **Auto login...** option to circumvent the standard Zetasizer log in window (and automatically log in as the current Windows user).
- **Folders** - Indicates and defines where the measurement data, SOPs and Export data are saved.
- **Macros** - Enables the selection and installation of additional programs.
- **Feature Keys** - This page allows extra features of the Zetasizer software to be enabled using a licence key.
- **Measurement** - This allows the look of the measurement display to be altered.
- **Instrument type** - This allows the selection of instrument type (Nano, μ V or APS). The system remembers this setting and uses the same mode the next time the software is started.

Security Menu

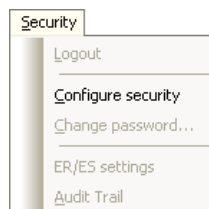

To prevent unauthorised changes, the Malvern software can be configured to limit each user's access to various functions - e.g. modifying an SOP. Users are assigned operating permissions that allow, or restrict, access; refer to **Chapter 7** for details.

Window Menu

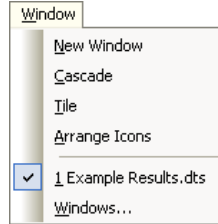

Use this menu to alter the view characteristics of any measurement file windows that are open - i.e. minimise, tile, and cascade the measurement file windows.

Select **Window-Windows...** to open the view dialogue.

Help Menu

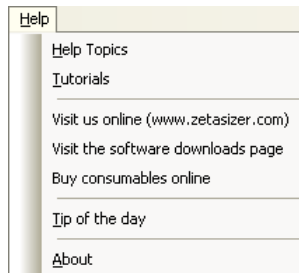

Help Topics... give access to the help files.

Links to the Malvern website... including downloads and consumables.

Tip of the day... will give hints on how to use the Zetasizer software; a different tip will appear each time this is selected. An option is given for turning off the Tip of the day dialogue that appears when the software starts.

About... gives details on the software version installed. Quote this if contacting Malvern Instruments.

② Toolbars

The toolbars contain a selection of tools that can be used to perform the most popular operations. Each tool will have its equivalent commands within the menu bar. For example, using the **Open** tool is equivalent to using the **File-Open** menu item.

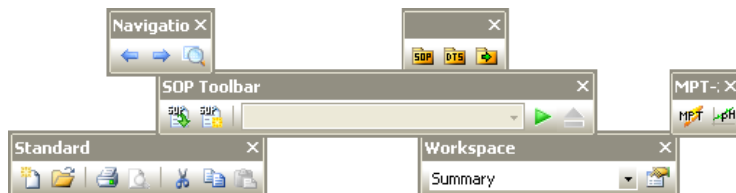

To identify each tool's function, move the cursor over a tool - a tool tip will be displayed under each tool with a short description of its action displayed in the status bar. As with the menu bar, if a tool, or accessory, is not available it will be shown "greyed out".

Standard	These tools perform the most popular File and Edit menu options functions.
Navigation	Use the arrow icons to scroll up and down the records list. The Plate Navigator button is for viewing measurements that were made using a Zetasizer APS instrument. Greyed out for results made using a Zetasizer μ V.
Folders	Selecting either of these will open the required folder - SOP, Measurement Data or Export - in a new window. This window is separate from the main application allowing the files to be copied, moved or deleted.
SOP Toolbar	The SOP toolbar records the most recent SOPs used to enable quick selection. This list will also include any recent SOP player (.sopl) files. Refer to Chapter 9 for more information. The eject button is greyed out and reserved for use when using a Zetasizer APS instrument.
Workspace	Allows selection and configuration of the Workspaces. Refer to Chapter 8 .

The content and appearance of the toolbar can be changed using the **View-Toolbars-Customise** option.

③ Measurement file window

The measurement file window displays all the information for 'one' measurement file. More than one measurement file window can be displayed at a time. The contents of the window will change when a **Record** or **Report tab** is selected.

Manipulation of the measurement file windows is described in **Chapter 5**.

Measurement file workspace

Workspaces allow configurable selection of record view parameters and reports that are only relevant to a particular measurement type. Similarly a user can create a personalised workspace so that only parameters and reports relevant to them will be shown.

Record and Report tabs

Measurement records are viewed with the **Records view** tab; this gives a listing of all the measurement records in any measurement file. The **Records view** tab is always shown as the prominent report tab when a new measurement file is opened.

If selected using the **View** menu, a **Statistics bar** will be available at the bottom of the record view. This can display the Standard deviation, the minimum, the maximum or the mean for the records selected.

The parameters shown are selected by the **Record View parameters** tab in the **Workspace** dialogues.

Selecting a **report tab** will display a predefined report as selected by the **Report pages** tab in the **workspace** dialogues. Malvern supplies several reports that give different views of the measurement settings and results, whilst custom reports can be generated using the **Report Designer**.

Details on interpreting the reports can be found in **Chapter 5**.

④ Title bar

The title bar displays the software name and the file name of the currently selected measurement file.

⑤ Measurement display

When a measurement is being performed a **measurement display** will appear.

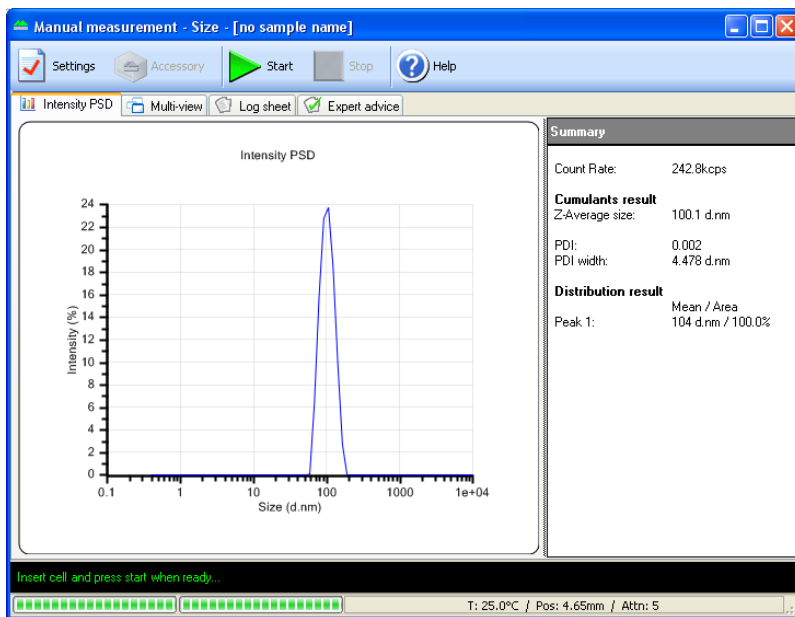

The Measurement display shows the progress of the measurement. The screen display shown changes depending on the type of measurement being performed and the view tab selected.

⑥ Status bar and Status icons

The status bar gives an indication of the instrument’s current operating state and an extended description of the tool icons. If required, use the **View-Toolbars-Customise....** dialogues to disable it.

On the right of the status bar, icons are shown to detail the operating state of the instrument and what additional features may be installed.

μ V icon

Double-clicking the μ V icon displays the Zetasizer μ V model, serial number, software and firmware version of the instrument (only if the instrument is connected and switched on).

If the instrument is disconnected from the software the icon will be greyed out:



21 CFR 11 icon

If the **21 CFR part 11** feature key is installed, the **21 CFR 11** icon will appear in blue on the right of the status bar.

If unavailable the icon will be 'greyed' out, like this: 

Double-clicking the icon will display the feature key number.

Please note that the **21 CFR part 11** option is **not** detailed in this manual.

Malvern defined features

Within the software, various parameters, settings or reports will have either a small Malvern logo () or an (M) alongside. This identifies it as Malvern defined and cannot be overwritten. The Malvern defined parameters can be used as a template that can be altered and saved under a different name.

Units Conversion

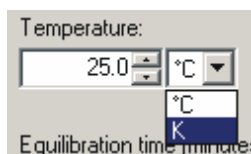

A number of parameters within the software have the option to change the units used to define the parameter, i.e. Temperature has the option to use either **°C** (Celsius) or **K** (Kelvin).

For all parameters where this option applies a scroll down list will be available alongside the parameter. The units can be selected in the SOP and other dialogues throughout the software.

The data is stored with a set of defaults, and is displayed with the selected units defined in the workspace chosen. This means that a particular record will be displayed with different units depending on the definition in the workspace used.

The Parameter unit chosen in the SOP dialogues will be displayed in all results and reports.

It is possible to subsequently alter the units used for the parameters in the Record and Report views - refer to **Chapter 5**.

A Tutorial - Making a measurement

Introduction

After reading this chapter a user should be able to make simple measurements. The chapter goes through the basics from turning on the system to displaying the results of a measurement.

The first section, “**Quick guide to making a measurement**” will run through the basic steps, giving an overview of the measurement process. The rest of the chapter will go through the same steps but in more detail.

Once a measurement has been completed, the result can be edited to check the effects if one of the measurement parameters was altered - refer to **Editing the result** in **Chapter 10**.

Manual and SOP measurements

There are two basic measurement methods: **Manual** measurements and **Standard Operating Procedure (SOP)** measurements. It is important to understand and consider these methods before proceeding.

- A **Manual** measurement is basically a one-off measurement where all the measurement parameters are set up immediately prior to the measurement. This is ideal if measuring many different types of sample, or experimenting with the measurement parameters.
- An **SOP** measurement uses pre-set parameters (that have previously been defined) to ensure that measurements made on the same type of sample are made in a consistent way; this is useful in quality control environments. SOPs are also ideal if measuring the same sample in slightly different ways; having to type a majority of identical parameters each time a measurement is made is tedious and runs the risk of making errors in the settings. Instead, alter an existing SOP and just change the required parameters.

Note that most of the settings and dialogues used for a manual measurement are the same as those used in an SOP measurement.

The sections that follow, **Quick guide to making a measurement**, etc, will focus on SOP measurements. **Chapter 9** will give details on creating and managing your a user's SOPs.

Quick guide to making a measurement

This section will give a brief overview of the measurement process using an SOP. More information on each stage can be found later in this chapter.

- Close the lid and **Turn on the instrument** and wait 30 minutes for the laser to stabilise.
- **Start the Zetasizer software.**
- **Prepare the sample** following the sample preparation guidelines.
- **Choose the cell(s)** appropriate for the sample and measurement type.
- **Fill the cell(s)** with the prepared sample.
- **Make an SOP measurement.**

If necessary **Open or create a new measurement file.**

Select **Measure-Start SOP** from the Zetasizer software.

Select the **SOP** required and select **Open.**

Follow any onscreen instructions that appear.

The **Measurement display** will now be shown.

- When requested, **insert the cell** into the instrument and wait for the temperature to stabilise.
- Click **Start** . The measurement will be made and the results displayed and saved to the open measurement file.

Powering up the system

To power up the system, **Turn on the instrument** and then **Start the software.**

Turning on the instrument

At switch on an **initialisation routine** is performed that checks the instrument is functioning correctly.

Close the lid and **turn on** the optical unit, switch on the power at the power socket and turn the power switch at the rear of the unit on.

**Note**

Important! All laser based measuring instruments should be powered up for around 30 minutes before measurements are made. This is to prevent any thermal equilibration problems affecting the measurement results.

Starting the Zetasizer software

Double click on the icon to start the software.

If the desktop icon is not available, select **Start-All Programs-Malvern Instruments-Zetasizer-Zetasizer** to start the program.



Sample preparation

The process of making a measurement is very simple - insert the sample into the instrument and then use the software to run either an SOP or manual measurement. However, the preparation of the sample before it is inserted into the instrument is paramount. See **Chapter 6** for more information.

Choosing the correct cell

**Caution!**

Due to the risk of melting, polystyrene cuvettes must not be used for measurements above 50°C.

Malvern offers a range of cells for performing measurements with the Zetasizer μV . The choice of cell is dependent upon the type of measurement being performed and the sample that will be measured. The choices for each measurement type are outlined below with some discussion on their use.

General advice

Generally, for “easy to perform” measurements, such as with samples that scatter a reasonable amount of light (latex with 0.01% mass or higher, high scattering intensity, etc.) the disposable polystyrene cuvettes can be used.

- Disposable polystyrene cuvettes are easily scratched and should never be used more than once.
- Disposable cuvettes are not resistant to organic solvents, thus non-water based samples should generally be measured in glass or quartz type cuvettes.

The optical quality of the cells is vitally important when performing Molecular weight and protein measurements, therefore glass or quartz type cuvettes should be used to ensure the optimum signal is achieved.

All the cells mentioned below are available from Malvern and should be used with the supplied cell caps. Using the caps will ensure greater thermal stability of the sample, as well as preventing dust introduction and possible spillage.

Size measurements

	Disposable polystyrene (DTS0012)	2 Microlitre Quartz Cuvette (ZMV1002)
Typical solvent	Water, Water/ethanol	Water, most organic and inorganic solvents
Optical quality	Good to very good	Excellent
Minimum Sample volume	1ml	2µl
Advantages	Low cost Single use disposable (no cleaning)	Highest optical quality Can use nearly any solvent Low sample volume
Disadvantages	Not resistant to organic solvents Unsuitable for use at high temperatures (above 50°C)	Requires cleaning after measurement Requires careful filling to avoid bubbles
Material	Polystyrene	Quartz

	Disposable low volume polystyrene (ZEN0117)	Glass - round aperture (PCS8501)
Typical solvent	Water, Water/alcohol	Water, most organic and inorganic solvents
Optical quality	Good to very good	Excellent
Minimum Sample volume	100µl	1ml
Advantages	Low cost Low volume Single use disposable (no cleaning)	Highest optical quality Can use nearly any solvent
Disadvantages	Requires careful filling to avoid bubbles Not resistant to organic solvents Unsuitable for use at high temperatures. (above 70°C)	Requires cleaning after measurement
Material	Polystyrene	Glass
	Glass - square aperture (PCS1115)	Low volume quartz (ZMV1012)
Typical solvent	Water, most organic and inorganic solvents	Water, most organic and inorganic solvents
Optical quality	Excellent	Excellent
Minimum Sample volume	1ml	12µl
Advantages	Highest optical quality Can use nearly any solvent Reusable	Highest optical quality Can use nearly any solvent Low sample volume
Disadvantages	Requires cleaning after measurement	Requires cleaning after measurement Requires careful filling to avoid bubbles
Material	Glass	Quartz

	Low volume Glass flow cuvette (ZEN0023)	Low volume quartz (ZMV1008)
Typical solvent	Water, most organic and inorganic solvents	Water, most organic and inorganic solvents
Optical quality	Excellent	Excellent
Minimum Sample volume	75µl plus tubing	8µl
Advantages	Highest optical quality Can use nearly any solvent (tubing dependent)	Highest optical quality Can use nearly any solvent Low sample volume
Disadvantages	Requires cleaning after measurement With manual use requires careful filling to avoid bubbles	Requires cleaning after measurement Requires careful filling to avoid bubbles
Material	Glass	Quartz

Molecular weight measurements

	Glass - round aperture (PCS8501)	Glass - square aperture (PCS1115)
Typical solvent	Water, most organic and inorganic solvents	Water, most organic and inorganic solvents
Optical quality	Excellent	Excellent
Minimum Sample volume	1ml	1ml
Advantages	Highest optical quality Can use nearly any solvent Reusable	Highest optical quality Can use nearly any solvent Reusable
Disadvantages	Requires cleaning after measurement	Requires cleaning after measurement
Material	Glass	Glass

Filling the cell

When filling the cell there are several actions to consider; some that apply to all cells and others that are only applicable to the measurement type and the cell chosen.

General advice

- Only **clean** cells should be used.

All **size** cells should be rinsed/cleaned with filtered solvent before use - see the **Cleaning the cells** section in the **Essentials manual**.

All **Molecular weight** cells should be rinsed/cleaned with the filtered standard (i.e. Toluene) or solvent, then dried in a dust free environment such as a laminar flow cabinet, before use.

- The cell should be filled slowly to avoid air bubbles from being created. Ultrasonication can be used to remove air bubbles - but only if the sample is suitable for use with ultrasonics.
- If using syringe filters for the solvent, never use the first few drops from the syringe, in case there are any residual dust particles in the filter that may contaminate the solvent.

Size and Molecular weight measurements

Standard cells

A minimum sample volume must be provided. However, this minimum volume depends on the actual cell type and it is easier to ensure a certain **depth** of the sample in the cell.

This **minimum** is **10mm** from the bottom of the cell (the measurement is made 8mm from the bottom of the cell).

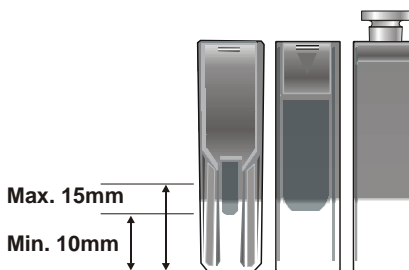

ill 6904

Do not overfill the cell, use about **15mm maximum**, as this can produce thermal gradients within the sample that will reduce the accuracy of the temperature control.

- **When filling**, tilt the cuvette and allow it to fill slowly (see above).
- To stop bubbles forming let the sample flow down the inside.

**Note**

When filled place a lid securely on the cuvette.

Low volume cell

This cell is designed to use the minimum volume of sample possible for a size or Molecular weight measurement. The sample must be pipetted carefully into the bottom of the cuvette, so it is filled from the bottom up.

The minimum volume that can be used is 12 microlitres. This will only partly fill the visible cell volume. After filling, carefully inspect the cell for trapped bubbles.

Inserting the cell

In the status bar, the software will prompt when the cell needs to be inserted. This will always be after the SOP has been started - see the next section. When and how the cell is inserted will depend on the application, and the measurement choices selected.

Size and Molecular weight measurements

For these measurements, do the following:

1. Press down on top of the cell area lid ① (where it is marked “Push”) to unlock the catch, and then release ②. The lid will rise to an upright, open position.

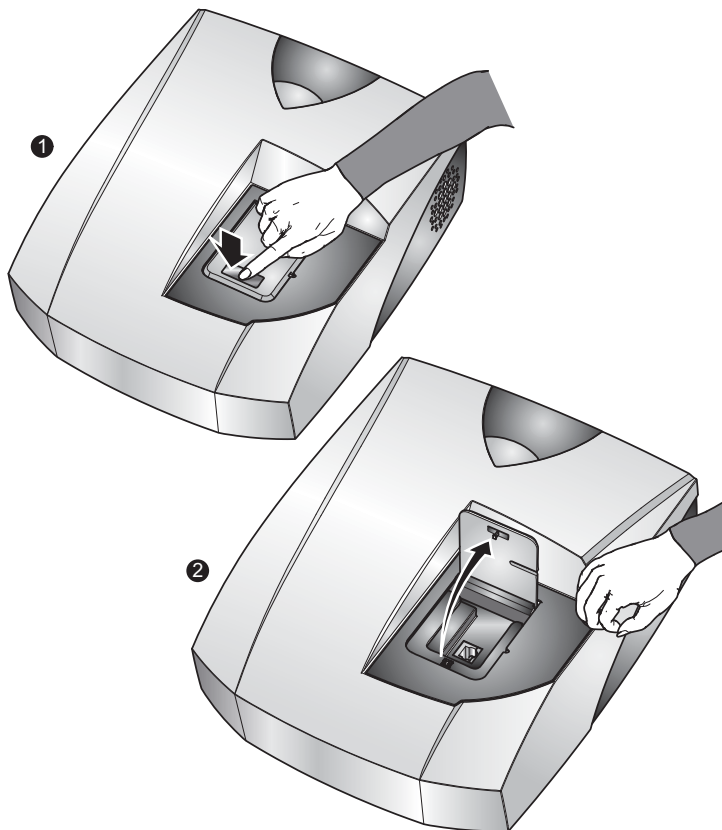

Hold the cell gently between thumb and finger, being careful to only hold the top part of the cell, and lower it into the cell holder until resistance is felt. iii 8313

Some cells have opaque surfaces as well as polished optical surfaces. A polished

optical surface must be inserted so that the “light path” indicator arrow in the cell enclosure passes through it - i.e. facing the front of the instrument. Most cells have a small triangle at the top to indicate the side that faces the front. This is especially critical for Molecular weight measurements.

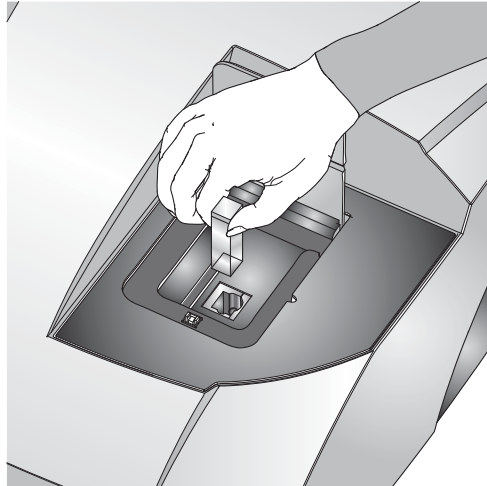

If a flowcell is used, insert the sample tubes into the threaded inserts and screw into the top of the flowcell. The tubing is then inserted into the channel on the side of the cell area.

2. Close the lid, pressing firmly where it is marked “Push” to secure the catch.

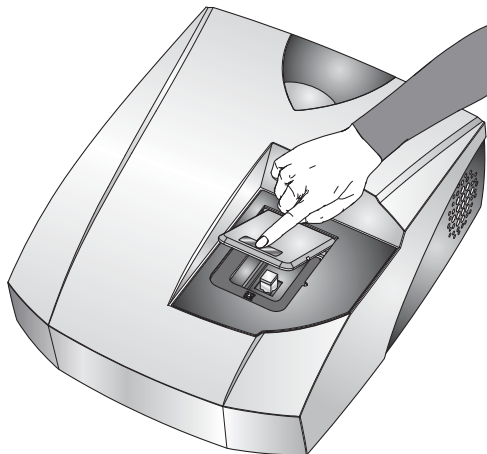

Making an SOP measurement

If a measurement is being made using an SOP, then all the hard work has already been done. The instrument has been turned on and the software started; the sample has been prepared and added to the cuvette. Now all that remains is to open or create a measurement file, open the required SOP, place the filled cuvette into the instrument and finally to press the **Start**  button.

This process is outlined below. **Chapter 9** gives all the detail required to create new SOPs.

Opening or creating a Measurement File.

Each time a measurement is made, the measurement data will be saved to a measurement file. How the measurement files are managed is down to preference. As an example:

- One measurement file is used for all the measurement records (not recommended).
- Separate files are used for each type of sample i.e. one for titanium dioxide and one for carbon black.
- A separate measurement file is used for each week or month.
- A separate measurement file is used for each user.



Note

If more than one measurement file window is open, the measurement record will be saved to the measurement file currently active. When the software starts it will automatically open the last measurement file used.

► To open an existing measurement file:

1. Select **File-Open-Measurement File** or .
2. A dialogue will appear allowing selection of a measurement file.
3. Select **Open**.

► To create a new measurement file:

1. Select **File-New-Measurement File** or .
2. A dialogue will appear allowing the new measurement file to be named and specify where it will be saved.
3. Select **Save**.

**Note**

All measurement files have the extension **.dts**. This is added automatically to all new files.

Starting an SOP measurement

Everything should now be ready to make the actual measurement.

To start an SOP measurement, select **Measure-Start SOP**. The **Open SOP** dialogue will appear. Select the SOP that will be used and select **Open**. If an SOP has not been specified for the sample, read **Chapter 9** for details on how to create one.

Pre-measurement instructions may appear advising of any actions that need to be performed before the measurement can proceed. Pressing **Sample** in the left column of the dialogue will open the **Sample** dialogue, allowing the measured sample to be named. This dialogue also allows any other information about the measurement to be entered in the **General notes** box, such as a batch number etc. Once the measurement record has been named and any comments added, select the **OK** button.

The **Measurement display**, discussed below, will now appear.

**Note**

It may be that the SOP was not configured to automatically show the **Sample** dialogue. If the dialogue does not appear, but is required, select the **Settings** button in the measurement display.

Follow the instructions on the status line of the measurement display - i.e. **Insert the Cell** (described above) and press the **Start**  button to start the measurement.

The progress of the measurement can be viewed in the **measurement display**. The measurement may take anything from two minutes to over an hour per measurement, depending on the settings within the SOP.

Once the **measurement sequence** (below) is complete, the **measurement display** can be closed with new record being shown in the measurement file window. The results can now be viewed - see **Displaying the results** in **Chapter 5**.

Making a manual measurement

Making a manual measurement is essentially the same as making an SOP measurement, except that, where as in an SOP measurement all the measurement options are pre-specified, here it will be necessary to set them immediately.

Instead of starting an SOP, select **Measure-Manual**. This will open the **Manual measurement** editor allowing any measurement types to be chosen and the settings to be configured.

The dialogues are virtually identical to those in the **SOP editor** when used to define a new SOP, please refer to **Chapter 9**.

Once all settings have been made, if required, select the **Save as...**  icon or **File-Save as...** from the menu to store the settings. Click the **OK** button to close the **Manual measurement** editor and return to the measurement display.



Note

The manual measurement settings can be viewed and subsequently saved by selecting **Edit-Extract SOP**.

The Measurement display

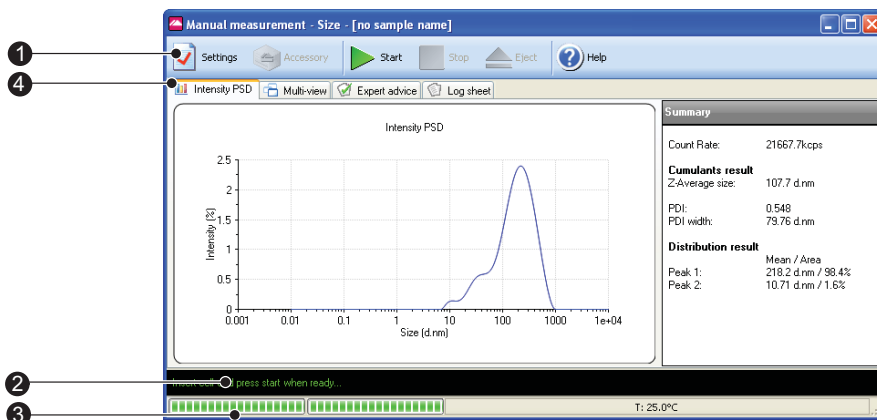

ill 8299

When an SOP or manual measurement is started the measurement display is displayed, showing the progress of the measurement.

The measurement display for all measurement types is generally the same and shows a number of dialogues representing the progress of the **measurement**

sequence. The dialogues displayed depend upon the measurement type selected. The diagram below shows the display for a size measurement.

The features of the measurement display are:

① Button bar

The button bar provides the control for the measurement operation.



The **Settings** button opens the measurement settings dialogue. Extra comments and changes to the measurement parameters can be added prior to the measurement being started.



These **Start** and **Stop** the measurement. If **Stop** is pressed while performing a measurement then the measurement must be started again from the beginning. **Stop** does not act like a pause.

When **Stop** is pressed, a warning box will appear asking “**Are you sure you wish to abort the measurement**”.



Opens the **Help** file.



The **Accessory** button is greyed out - only available for Zetasizer Nano instruments.

When the **Start** button is pressed the Manual control dialogue will be **closed**.

② Status bar

The status bar shows instructions and the current operation in the measurement sequence.

③ Progress meter

The progress meter shows how far the measurement has progressed plus the number of measurements performed and the measurement runs completed. Also shown are the temperature, measurement position and attenuator settings.

④ Tab views

The **Tab views** enable the progress and results of the measurement to be viewed. The **first** tab shows the results, and will change with respect to the measurement type and results view selected. In the above example, this tab is labelled **Intensity PSD** to identify that intensity results are being viewed. This tab shows different graph plots relevant to the measurement type selected. The other three tabs dialogues - **Multi-view**, **Log sheet** and **Expert advice** - are standard for each Measurement type.

- The views displayed in the **first** (result) tab, can be altered by right-clicking on the graph and selecting from the list displayed. A graph only, or a graph with a summary table will be shown depending upon the view chosen. The **Result** tab is named after the result view chosen.
- The **Multi-view** tab displays the results in three smaller windows. As with the **first** (result) tab, the view in each separate window can be altered by right-clicking in the window and selecting a different view from the list displayed. The size of each window can altered by moving the borders around.

The Tab views for each measurement type are described below.

Size measurements

Result tab (1st tab)

The **result** tab will show the result obtained as the measurement progresses. The result view will be updated after every run of the measurement. The result shown will be the sum of the acceptable data collected.

The **Result** tab is named after the result view chosen, the default result view shown is **Intensity PSD**. Different views can be selected by right-clicking on the graph and selecting from the list displayed. A graph only, or a graph with a summary table will be shown depending upon the view chosen.

The views available are: **Count Rate**, **Correlation Function**, **Intensity PSD**, **Volume PSD** and **Number PSD**. These are described below.

■ Count rate

Displays the number of photons detected per second. The count rate is useful for monitoring the sample quality.

Normal count rate display.

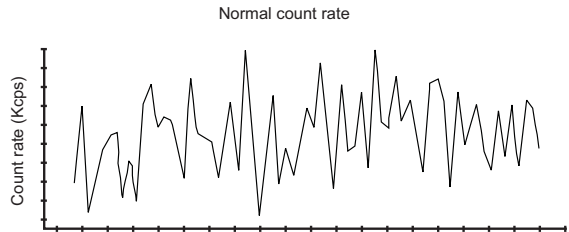

ill 8376

If dust is present then sharp spikes will be observed. Measurement runs with dust present will be removed from the final measurement calculation by a dust filtration algorithm.

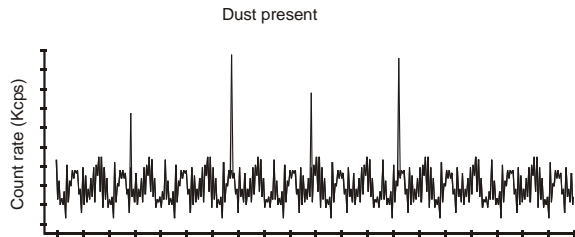

ill 6757

A wildly fluctuating count rate may indicate that thermal gradients are present in the sample, and further time is required for temperature equilibration.

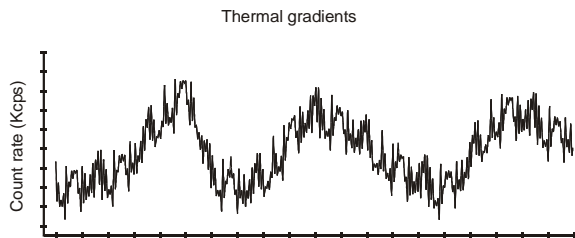

ill 6758

A steadily increasing count rate will indicate an aggregating sample, while a decreasing count rate will indicate a sedimenting sample.

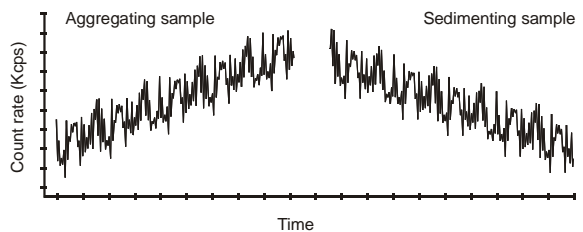

ill 6759

■ Correlation function

The correlation function helps the experienced user to interpret any problems with the sample.

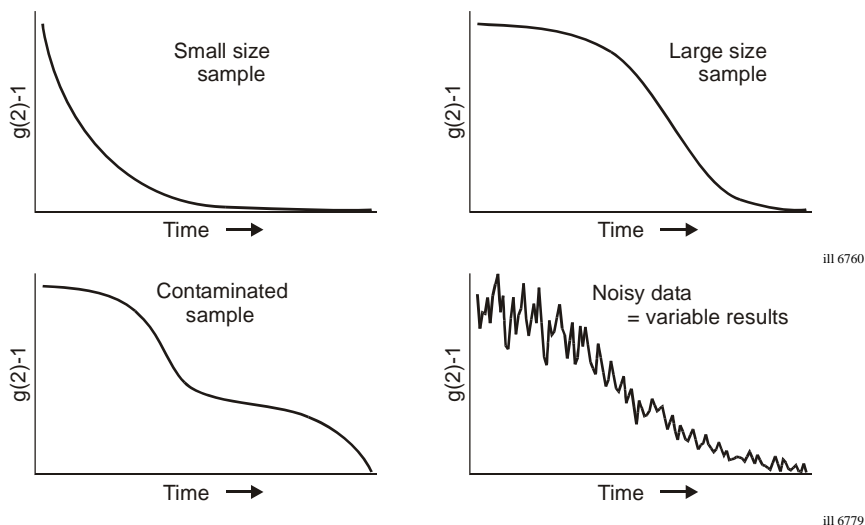

■ Intensity PSD

Displays the result as an Intensity based Particle Size Distribution. A summary table will displayed alongside the graph.

■ Volume PSD

Displays the result as a Volume based Particle Size Distribution. A summary table will displayed alongside the graph.

■ Number PSD

Displays the result as a Number based Particle Size Distribution. A summary table will displayed alongside the graph.

Multi-view Tab

The Multi-view enables three different result views to be shown at the same time. The view in each separate window can be altered by right-clicking in the window and selecting a different view from the list displayed. The same views as used in the result tab are available.

Log sheet Tab

This displays the progress of the measurement. The log sheet can be saved by right-clicking the mouse on it, pressing the **Save to file...** button that appears and saving it as a **.txt** file.

Expert Advice Tab

The Expert Advice tab reports on how good the quality of the measurement is. This will show how good the measurements are and whether they display any unwanted attributes, such as aggregation.

Refer to the **Expert Advice** section in **Chapter 10** for a description.

Molecular weight measurements

Result tab (1st tab)

Please also refer to size description above.

For Molecular weight measurements the default result view shown is a **Debye** plot.

The Different views that can be selected are described below: **Intensity PSD**, **Count Rate**, **Correlation Function**, **Volume PSD**, **Number PSD** and **Debye**.

- **Intensity PSD**

The result view will be updated after each of the individual concentration measurements. The result shown will be an evolving value from the data collected so far.

Please refer to the Size description above.

- **Count rate**

Please refer to the Size description above.

- **Correlation function**

Please refer to the Size description above.

- **Volume PSD**

Please refer to the Size description above.

- **Number PSD**

Please refer to the Size description above.

- **Debye**

Displays the current result as a Debye plot. The Debye plot displayed will show an evolving plot generated from the data collected so far.

Multi-view Tab

This is as the Size description above, except for Molecular weight specific view choices.

Log sheet Tab

Please refer to the Size description above.

Expert Advice Tab

Please refer to the Size description above.

Flow-mode measurements

Result tab (1st tab)

The result tab will show the result obtained as the measurement progresses. The result view will be updated after every run of the measurement.

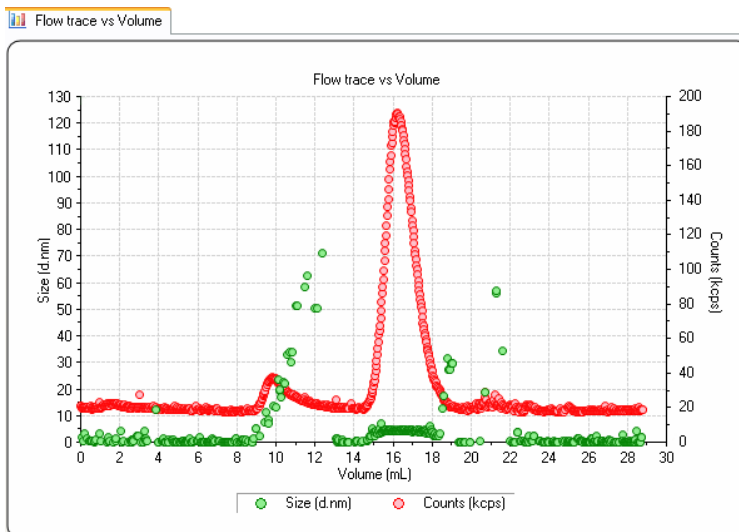

The Result tab is named after the result view chosen, the result view shown above is **Flow trace vs Time**. Different views can be selected by right-clicking on the graph and selecting from the list displayed.

The views available are: **Count Rate**, **Correlation Function**, **Flow trace vs Volume** and **Flow trace vs Time** and **Monitor**.

- **Monitor** enables the count rate signals to viewed before a measurement is run.

Multi-view Tab

As the Size description above, except for Flow-mode specific view choices.

Log sheet Tab

Please refer to the Size description above.

Expert Advice Tab

Please refer to the Size description above.

Trend measurements

The trend dialogues are generally the same as those used when either a size or Zeta measurement SOP is chosen. The difference is the inclusion of an extra **Trend** graph view - this will show an evolving plot as the measurement progresses.

Melting Point measurements can be performed using the Trend measurement type.

Measurement sequence



Note

The status bar will prompt for certain actions during the course of the measurement.

Before the measurement sequence begins the cell temperature will change to the starting temperature requested in the SOP.

The measurement will then continue with an optimisation or initialisation stage where the cell positions, compensation and attenuator settings for the cell, sample and measurement type will be determined.

Monitoring the **status bar** or clicking on the **Log sheet** tab will give more detail about what is happening during this procedure. The **progress meter** indicates how far the system is through the optimisation stages.

Once these stages have been completed, the measurement proper will start; again the actual measurement sequence will depend upon the measurement being performed.

The paragraphs that follow describe the main measurement types the Zetasizer μ V performs: **Size** and **Molecular weight**.

Size measurements

The cell is inserted, **Start** is pressed and data collection begins. The progress meter indicates the measurement progress, while **Measurement** and **Run** show the number of runs completed and measurements performed.

The measurement is divided into a number of 'runs', This is done to allow data filtering. At the end of data collection the data quality of each 'run' is assessed; the runs that contain the poorest data are rejected while the remaining runs are analysed and used in the final measurement calculation.

As soon as a run is completed, a preliminary size result will be available to view (by clicking on the tab). As more runs are made and assessed the quality of the result will improve.

Molecular weight measurements

The Molecular weight measurement sequence requires a series of intensity measurements to be made, first of a standard to establish the reference scattering intensity, and then of each of a number of prepared sample concentrations. At each part of the sequence the user will be prompted for the insertion of the next concentration. As this requires more interaction than for size measurements, the sequence has been described below:

- Press **Start** to begin the dark count measurement. The laser is turned off and a measurement is taken of the background light level.
- Insert the scattering standard cell (i.e. Toluene) and press **Start** when ready. The measurement will measure the scattering intensity of the scattering standard used.
- Once the standard has been measured, a dialogue box will appear to prompt insertion of the first sample concentration (i.e. the pure solvent). Insert the first sample concentration and press **Start**.
- The software displays another dialogue where the sample concentration can be entered. Type in the concentration and press **Enter**. The measurement will then continue.
- On completion of the first sample measurement, a dialogue is displayed - answer **Yes** to “Repeat measurement of concentration 1?” or **No** to continue with the second concentration.
- Continue as above until all sample concentrations have been measured.
- On completion of the last concentration the final result will be calculated.

The progress meter indicates the measurement progress during each stage.

Records and Reports

- Viewing the Results

Introduction

Once a measurement has finished the results will need to be reviewed. This chapter details how to display the final measurement result.

The final result is displayed in the measurement file window as either a measurement record or report.

Displaying the results

The results are displayed in two ways. A **Records view** that shows a list of the measurement records in a measurement file, and the **Report tabs** which show all measurement details of a selected measurement record.



Note

The **Records view** parameters and **Report tabs** that are displayed are dependent upon the **Workspace settings** selected- refer to **Chapter 8**.

Records view

Once the measurement is complete, a new measurement record will be added to the **Records view** of the measurement file window. The records will be sequentially numbered. Records are automatically assigned a record number on completion of the measurement.

The parameters shown will be those selected using the **Tools-Settings-Configure Workspace** dialogues, the record view shown below depicts the default **summary** workspace (see **Chapter 8**).



Record	Type	Sample Name	Measurement Date and Time	T	Z-Ave	Pd	Pk 1 Mean Int	Pk 2 Mean Int	Pk 3 Mean Int	Pk 1 Area Int	Pk 2 Area Int	Peak 3 Area Int
1	Size	Multi-measurement test 1	02 September 2008 09:49:10	25.0	53.77	0.344	61.04	0.000	0.000	100.0	0.0	0.0
2	Size	Multi-measurement test 1	02 September 2008 09:50:39	25.0	53.53	0.251	56.27	0.000	0.000	100.0	0.0	0.0
3	Size	Multi-measurement test 1	02 September 2008 09:51:58	25.0	73.61	1.000	64.72	0.000	0.000	100.0	0.0	0.0
4	Size	Multi-measurement test 1	02 September 2008 09:53:14	25.0	61.13	0.402	60.02	0.000	0.000	100.0	0.0	0.0
5	Size	Multi-measurement test 1	02 September 2008 09:54:35	25.0	50.96	0.024	54.12	0.000	0.000	100.0	0.0	0.0
6	Size	Multi-measurement test 1	02 September 2008 09:56:04	25.0	127.9	1.000	57.43	0.000	0.000	100.0	0.0	0.0
7	Size	Multi-measurement test 1	02 September 2008 09:58:08	25.0	173.5	1.000	50.30	0.000	0.000	100.0	0.0	0.0
8	Size	Multi-measurement test 1	02 September 2008 10:00:36	25.0	64.32	0.671	60.21	0.000	0.000	100.0	0.0	0.0
9	Size	Multi-measurement test 1	02 September 2008 10:02:02	25.0	0.000	1.000	30.52	0.000	0.000	100.0	0.0	0.0
10	Size	Multi-measurement test 1	02 September 2008 10:03:29	25.0	12.46	1.000	30.20	0.000	0.000	100.0	0.0	0.0
11	Size	Multi-measurement test 1	02 September 2008 10:04:36	25.0	0.000	1.000	31.15	0.000	0.000	100.0	0.0	0.0
12	Size	Multi-measurement test 1	02 September 2008 10:05:54	25.0	16.49	1.000	29.97	0.000	0.000	100.0	0.0	0.0
13	Size	Multi-measurement test 1	02 September 2008 10:07:19	25.0	65.29	1.000	56.65	0.000	0.000	100.0	0.0	0.0
14	Size	Multi-measurement test 1	02 September 2008 10:08:49	25.0	53.66	0.024	54.78	0.000	0.000	100.0	0.0	0.0
15	Size	Multi-measurement test 1	02 September 2008 10:10:04	25.0	76.69	1.000	48.99	0.000	0.000	100.0	0.0	0.0
16	Size	Multi-measurement test 1	02 September 2008 10:11:37	25.0	51.24	0.122	55.65	0.000	0.000	100.0	0.0	0.0
17	Size	Multi-measurement test 1	02 September 2008 10:12:53	25.0	55.21	0.266	64.14	0.000	0.000	100.0	0.0	0.0
18	Size	Multi-measurement test 1	02 September 2008 10:14:27	25.0	70.1	1.000	55.34	0.000	0.000	100.0	0.0	0.0
19	Size	Multi-measurement test 1	02 September 2008 10:15:52	25.0	72.03	1.000	31.43	0.000	0.000	100.0	0.0	0.0
20	Size	Multi-measurement test 1	02 September 2008 10:17:30	25.0	1602	1.000	28.73	0.000	0.000	100.0	0.0	0.0
21	Size	Multi-measurement test 1	02 September 2008 10:18:50	25.0	2340	1.000	31.15	0.000	0.000	100.0	0.0	0.0
22	Size	Multi-measurement test 1	02 September 2008 10:20:16	25.0	51.42	1.000	29.29	0.000	0.000	100.0	0.0	0.0
23	Size	Multi-measurement test 1	02 September 2008 10:21:31	25.0	69.4	1.000	31.37	0.000	0.000	100.0	0.0	0.0
24	Size	Multi-measurement test 1	02 September 2008 10:23:00	25.0	0.000	0.000	0.000	0.000	0.000	0.0	0.0	0.0
25	Size	Multi-measurement test 1	02 September 2008 10:25:21	25.0	11.38	0.225	6.630	3283	0.000	77.5	22.5	0.0
26	Size	Multi-measurement test 1	02 September 2008 10:26:40	25.1	0.000	0.313	0.000	0.000	0.000	0.0	0.0	0.0
27	Size	Multi-measurement test 1	02 September 2008 10:28:19	25.0	0.000	1.000	0.000	0.000	0.000	0.0	0.0	0.0
28	Size	Multi-measurement test 1	02 September 2008 10:30:05	25.0	0.000	0.000	0.000	0.000	0.000	0.0	0.0	0.0
29	Size	Multi-measurement test 1	02 September 2008 10:34:11	25.0	0.000	0.000	0.000	0.000	0.000	0.0	0.0	0.0
30	Size	Multi-measurement test 1	02 September 2008 10:35:48	25.0	0.000	0.000	0.000	0.000	0.000	0.0	0.0	0.0
Mean 7				25.0	173.5	1.000	50.30	0.000	0.000	100.0	0.0	0.0
Std Dev												









Melting point records

To view a sequence of Melting point records, select the first record in the sequence; all subsequent records in that sequence will then automatically be selected.

Outliners

For Melting point records, **outliners** are employed. This enables the main 'parent' record to be shown without the 'child' records also being displayed.

Selecting  will display the 'child' records, selecting  will hide them.

28	Size	60nm Latex
29	Size	60nm Latex
30	Size	60nm Latex
31	Size	220nm Latex
	37 Melting Point	Hb in PBS
	38 Size	Hb in PBS
	39 Size	Hb in PBS
	40 Size	Hb in PBS
	41 Size	Hb in PBS
	42 Size	Hb in PBS
	43 Size	Hb in PBS
	44 Size	Hb in PBS
	45 Size	Hb in PBS

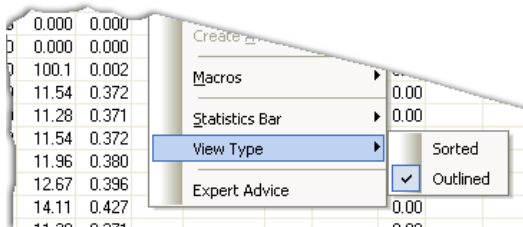

The Outlined record view can be turned off and on by selecting **View-View type-Sorted** or **Outlined** or by right-clicking the mouse on the table, as shown above.

Statistics bar

Use this to display the Standard deviation, the Relative Standard deviation, the minimum, the maximum or the mean of a selected number of records. Select **View-Statistics bar** from the menu bar, and then the options to display. A bar will be added to the bottom of the record view displaying each of the parameters selected.

Record	Type	Sample Name	Measurement Date and Time	T °C	Z-Ave d.nm	PdI	Pk. 1 Mean Int d.nm	Pk. 2 Mean Int d.nm	Pk. 3 Mean Int d.nm	Pk. 1 Area Int %	Pk. 2 Area Int %	Peak 3 Area Int %	Intensity	Agg
5	Size	Sample1 1	21 October 2008 12:46:47	25.0	276.1	0.065	263.1	0.000	0.000	100.0	0.0	0.0	0.0	0.0
6	Size	Sample1 2	21 October 2008 12:47:39	25.0	273.0	0.154	270.2	0.000	0.000	100.0	0.0	0.0	0.0	0.0
7	Size	Sample1 3	21 October 2008 12:48:32	25.0	265.6	0.014	271.6	0.000	0.000	100.0	0.0	0.0	0.0	0.0
8	Size	Sample1 4	21 October 2008 12:49:25	25.0	273.0	0.139	261.0	0.000	0.000	100.0	0.0	0.0	0.0	0.0
9	Size	Sample1 5	21 October 2008 12:50:18	25.1	273.5	0.169	279.2	0.000	0.000	100.0	0.0	0.0	0.0	0.0
10	Size	Sample1 6	21 October 2008 12:51:11	25.0	286.4	0.091	292.0	0.000	0.000	100.0	0.0	0.0	0.0	0.0
11	Size	Sample1 7	21 October 2008 12:52:04	25.0	271.7	0.225	248.1	0.000	0.000	100.0	0.0	0.0	0.0	0.0
12	Size	Sample1 8	21 October 2008 12:52:56	25.0	284.6	0.032	289.4	0.000	0.000	100.0	0.0	0.0	0.0	0.0
13	Size	Sample1 9	21 October 2008 12:53:43	25.0	288.0	0.174	305.3	0.000	0.000	100.0	0.0	0.0	0.0	0.0
14	Size	Sample1 10	21 October 2008 12:54:42	25.0	268.0	0.140	275.5	0.000	0.000	100.0	0.0	0.0	0.0	0.0
15	Size	Sample1 11	21 October 2008 12:55:35	25.0	277.4	0.108	278.3	0.000	0.000	100.0	0.0	0.0	0.0	0.0
16	Size	Sample1 12	21 October 2008 12:56:28	25.0	270.2	0.020	279.0	0.000	0.000	100.0	0.0	0.0	0.0	0.0
17	Size	Sample1 13	21 October 2008 12:57:21	25.0	279.1	0.059	290.6	0.000	0.000	100.0	0.0	0.0	0.0	0.0
18	Size	Sample1 14	21 October 2008 12:58:14	25.0	279.0	0.065	276.0	0.000	0.000	100.0	0.0	0.0	0.0	0.0
19	Size	Sample1 15	21 October 2008 12:59:06	25.0	277.6	0.029	286.0	0.000	0.000	100.0	0.0	0.0	0.0	0.0
20	Size	Sample1 1	21 October 2008 13:04:37	25.0	280.2	0.104	309.9	0.000	0.000	100.0	0.0	0.0	0.0	0.0
21	Size	Sample1 2	21 October 2008 13:05:30	25.0	268.9	0.140	281.6	0.000	0.000	100.0	0.0	0.0	0.0	0.0
22	Size	Sample1 3	21 October 2008 13:06:23	25.0	288.9	0.026	288.8	0.000	0.000	100.0	0.0	0.0	0.0	0.0
23	Size	Sample1 4	21 October 2008 13:07:15	25.0	288.2	0.105	284.2	0.000	0.000	100.0	0.0	0.0	0.0	0.0
24	Size	Sample1 5	21 October 2008 13:08:08	25.0	278.9	0.065	277.6	0.000	0.000	100.0	0.0	0.0	0.0	0.0
25	Size	Sample1 6	21 October 2008 13:09:01	25.0	290.7	0.043	297.8	0.000	0.000	100.0	0.0	0.0	0.0	0.0
26	Size	Sample1 7	21 October 2008 13:09:54	25.0	273.3	0.139	285.5	0.000	0.000	100.0	0.0	0.0	0.0	0.0
27	Size	Sample1 8	21 October 2008 13:10:47	25.0	262.1	0.097	261.4	0.000	0.000	100.0	0.0	0.0	0.0	0.0
28	Size	Sample1 9	21 October 2008 13:11:39	25.0	261.7	0.112	262.0	0.000	0.000	100.0	0.0	0.0	0.0	0.0
29	Size	Sample1 10	21 October 2008 13:12:32	25.0	270.2	0.211	269.5	0.000	0.000	100.0	0.0	0.0	0.0	0.0
30	Size	Sample1 11	21 October 2008 13:13:25	25.0	283.2	0.163	278.6	0.000	0.000	100.0	0.0	0.0	0.0	0.0
31	Size	Sample1 12	21 October 2008 13:14:18	25.0	276.6	0.006	279.9	0.000	0.000	100.0	0.0	0.0	0.0	0.0
32	Size	Sample1 13	21 October 2008 13:15:11	25.0	284.9	0.142	296.0	0.000	0.000	100.0	0.0	0.0	0.0	0.0
33	Size	Sample1 14	21 October 2008 13:16:03	25.0	261.9	0.079	266.0	0.000	0.000	100.0	0.0	0.0	0.0	0.0
34	Size	Sample1 15	21 October 2008 13:16:56	25.0	274.6	0.008	279.3	0.000	0.000	100.0	0.0	0.0	0.0	0.0
Mean 13.15:20				25.0	282.0	0.129	294.0	0.000	0.000	100.0	0.0	0.0	0.0	0.0
Std Dev				0.0	4.665	0.022	15.89	0.000	0.000	0.0	0.0	0.0	0.0	0.0
RSD %				0	1.72	24.9	5.4	0	0	0	0	0	0	0

To display the statistics of a number or records, hold down **Shift** or **Ctrl** and then the records required in the normal Windows fashion; the statistics bar will be automatically updated as each record is chosen.

View-Statistic bars-Hide will remove the statistics bar from the record view.

Units conversion

Within the Records view, it is possible to change the units used to define some of the parameters. If the option is available, clicking on a parameter column will

display a **parameter icon** enabling the units to be changed. A check mark (✓) will be displayed next to the currently selected units.

Z-Ave	PDI	ZP
d.nm		mV
10.1	✓ d.nm	
11.1	r.nm	



Note

Changing the units of a parameter will alter the units for each occurrence of the parameter in any report then displayed.

Report tabs - a typical view

Selecting a measurement record and then selecting any of the **report tabs** will display the measurement information for that record.

To view a sequence of Melting point or Titration records, select the first record in the sequence; all subsequent records in that sequence will then automatically be selected.

This includes the pre-measurement settings such as sample name, the SOP and the SOP parameters used; the system settings for the measurement to be performed and the measurement results. A graph or table is also included at the bottom of the report.



Note

For each report two views are created. One view shows the **printed** version, the other view shows the **computer screen** version. This is done to accommodate the different aspect ratios of the printed page and the computer screen.

In addition to the information described in the body of the report, the footer of the printed report will show the software version and serial number of the Zetasizer, the filename and record number of the measurement and the date printed, plus the Malvern contact phone number.

Each measurement type has a 'standard' report associated to it. The same result information is present in both the computer and printed versions, except for the diagnostic reports which contain extended information on the printed version.



Note

To show multiple results on one report, hold down **Shift** or **Ctrl** and select the required records and then click the required report tab.

Units conversion

As in the **Records view**, within the results section of each report, it is possible to change the units used to define some of the parameters displayed. If the option is available, right-clicking on a parameter will display a **parameter icon** enabling the units to be changed. A check mark (✓) will be displayed next to the currently selected units.

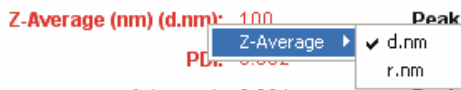

If present, right-clicking on the table will also bring up the option to change the units displayed. For a table, select **units** from the displayed menu.

Size d.nm	Mean Intensity %	Std Dev Intensity %	Size d.nm	Mean Intensity
5.61	0.0		78.8	
6.4	✓ Intensity		91.3	3
7.4	Volume		106	3
8.7	Number		122	1
10.7			142	
11.7			164	
13.4	Min/Max		190	
15.7			220	
18.2	✓ Mean/S.D.		255	
21.0			295	
24.4			345	
28.2	0.0		395	
32.7	0.0		455	



Note

Changing the units of a parameter in any field of the report, will alter the units for every other occurrence of the parameter in the report, and the parameter column in the **Records view**, however the default unit in the record is not changed.

Size measurements - standard report

The standard report for Size measurements is **Intensity PSD (M)**. (PSD stands for **P**article **S**ize **D**istribution).

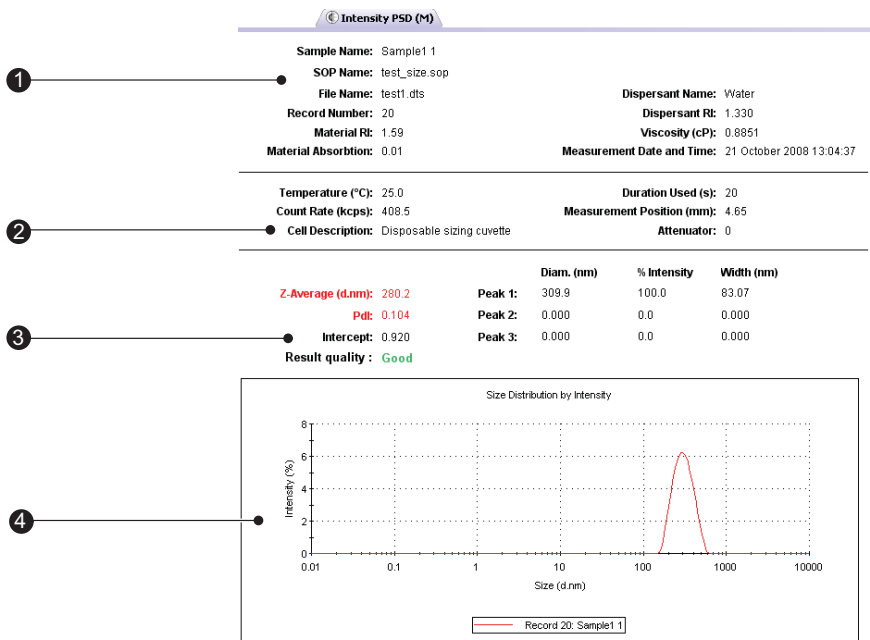

ill 8375

The report is divided into four areas; these are described below.

① Sample details

This section gives details of parameters relating to the sample. This includes the measurement name, record number, time of measurement, sample/solvent refractive indices, viscosity, etc. The information shown is generally that which was entered by the user into the SOP measurement dialogues.

② System details

This section gives details on instrument settings for this particular measurement. Specifically, these are:

- **Temperature**
Measured temperature at the start of the measurement.
- **Count rate**
Average count rate for the measurement.
- **Duration used(s)**
Duration of measurement, used in the analysis of the result.

- **Cell type**

This displays the cell type selected.

- ③ **Results**

This section gives the results of the measurement. The values given here will be based either on intensity, volume or number, depending on which view tab is selected.

The results section gives three pieces of information:

- **Z-average Size** (also known as the “cumulants mean”)

In **Dynamic Light Scattering (DLS)** this is the most important and stable number produced by the technique. This is the size to use if a number is required for quality control purposes.

It will only be comparable with other techniques if the sample is monomodal (i.e. only one peak), spherical and monodisperse (i.e. no width to the distribution), and the sample is prepared in the correct solvent.

In any other case, the Z-average size can only be used to compare results with samples measured in the same solvent, by the same technique.

The cumulants analysis only gives two values, a mean value for the size, and a width parameter known as the **Polydispersity**, or the **Polydispersity Index (PdI)**. It is important to note that this mean size (often given the symbol Z or z-average) is an intensity mean. It is not a mass or number mean because it is calculated from the signal intensity.

The cumulants analysis is actually the fit of a polynomial to the log of the G_1 correlation function.

$$\ln[G_1] = a + bt + ct^2 + dt^3 + et^4 + \dots$$

The value of b is known as the second order cumulant, or the z-average diffusion coefficient. This is converted to a size using the solvent viscosity and some instrumental constants.

Only the first three terms a, b, c are used in the standard analysis to avoid over-resolving the data; however this does mean that the Z-average size is likely to be interpreted incorrectly if the distribution is very broad (i.e. has a high polydispersity).

- **PdI**

The coefficient of the squared term, c , when scaled as $2c/b^2$ is known as the polydispersity, or polydispersity index (PdI).

The calculations for these parameters are defined in the ISO standard document 13321:1996 E and 22412.

- **Intercept**

This is the amplitude of the G_1 correlation function at time 0. For a good measurement it will be 0.85 to 0.95.

Lower values will be obtained for measurements on weaker scattering sample, or in turbid sample where background scattering is significant. Values > 1 will only occur for samples with dust that makes the sample fluctuate wildly.

- **Peak means**

Displays the size and percentage by either intensity, volume or number for up to three peaks within the result.

In summary, the cumulants analysis gives a good description of the size that is comparable with other methods of analysis for spherical, reasonably narrow monomodal samples, i.e. with polydispersity below a value of 0.1. For samples with a slightly increased width, the Z-average size and polydispersity will give values that can be used for comparative purposes. For broader distributions, where the polydispersity is over 0.5, it is unwise to rely on the Z-average mean, and a distribution analysis should be used to determine the peak positions.

④ **Graph**

The results are also shown in graphical form.

The format of the graph can be altered by moving the cursor over the graph and right clicking the mouse. The **Graph control properties** dialogue will appear. This dialogue allows the following attributes to be altered:

- **Display**

The **Display** tab allows a choice of graph type and how it is to be displayed. i.e. Either as a histogram or curve, or particular statistics shown.

The **Options** tab allows the graph key position to be chosen. A graph tips option can also be set, this allows the setting of pop up tips (flags showing data points on the graph) on the report itself.

- **Axis settings**

Allows both the X and Y axis settings to be defined. Whether **logarithmic** or **linear** axis are required and the axis scales - user defined or auto-scaling. **Graticule**, or grid lines can also be shown on the graphs.

- **Font**

Allows the font style to be altered. The setting will apply to all annotations used on the graph.

- **Upper/Lower limits**

Further tabs allow the setting of **Upper** and **Lower** warning or action **limits** so the value shown can be checked to be within desirable limits.

The graph below has been configured using the dialogue to display a Size Distribution by Intensity graph as a histogram, with logarithmic X-axis and linear

Y-axis settings. Graticule, or grid, lines have been included and upper action and warning limits have been set.

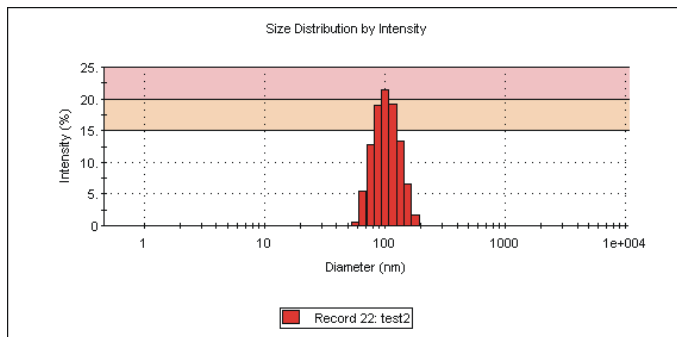

ill 6606

It is possible to zoom into a graph report. Simply hold down the left mouse button, and move the mouse to draw a “Marquee” (from top left to bottom right) around the area to be enlarged. To zoom back out, simply click the left mouse button on the graph.

**Note**

Though it is possible to change the appearance of the graph on the screen, when the report is printed out it will print the original default view. To print out a different graph a new report will have to be created using **Report designer**.

Other Size reports

Other Malvern views available for size measurements include:

- **Intensity Statistics (M)**
- **Volume psd (M)**
- **Volume Statistics (M)**
- **Number psd (M)**
- **Number Statistics (M)**
- **Size diagnostics report (M)**

This report shows six graphs: The size distribution by intensity and volume, size and cumulants residuals by time, and the data and cumulants fit. These graphs are helpful for more experienced users to determine the quality of their measurement data.

- **Size quality report (M)**

This report is described below.

- **Size quality report (M)**

This is a summary report detailing whether the result meets the Malvern Instruments quality criteria for a size measurement. The report indicates **Result meets quality criteria**, or **Result does not meet quality criteria** in which case a list of parameters that do not meet the criteria, and probable reasons will be displayed. Some of these parameters will only be displayed if the research software has been used for the measurement.

The parameters, followed by probable reasons displayed are:

- **z Average is smaller than lower size display limit**
Wrong size limits used in display range
- **z Average is larger than upper size display limit**
Wrong size limits used in display range
- **z Average is smaller than lower size analysis limit**
Wrong size limits used in analysis range
- **z Average is larger than upper size analysis limit**
Wrong size limits used in analysis range
- **Polydispersity index is very high**
Sample is very polydisperse and may not be suitable for DLS measurements
Sample contains large particles/aggregates/dust
Wrong measurement position selected
- **Correlation function intercept out of range**
Sample concentration too high (multiple scattering)
Sample concentration too low
Sample fluorescence
Sample absorbance (coloured samples)
Wrong measurement position selected
- **Check first correlation point selection for multimodal analysis**
- **In range figure is low**
Presence of large or sedimenting particles
Sample fluorescence
Sample absorbance (coloured samples)
- **Count rate is out of range (too low)**
Attenuator not set to automatic
Sample concentration too low
Sample absorbance (coloured samples)
Sample is not stable during measurement

- **Count rate is out of range (too high)**
 - Attenuator not set to automatic
 - Sample contains large particles/aggregates/dust
 - Sample is not stable during measurement
- **Insufficient signal collected**
 - Measurement duration not set to automatic
 - Filter factor in research software not set to default (50%)
- **Cumulant fit error high**
 - Data quality too poor for cumulant analysis
 - Sample too polydisperse for cumulant analysis
 - Inappropriate cumulant analysis settings in Research Software
- **Multimodal fit error high**
 - Data quality too poor for distribution analysis
 - Sample too polydisperse for distribution analysis
 - Inappropriate distribution analysis settings in Research Software
- **Check cumulants and distribution fit errors**
 - Sample too polydisperse for cumulant analysis - suggest rely on distribution analysis

Molecular weight measurements - standard report

The standard report for Molecular weight measurements is **Molecular weight report (M)**.

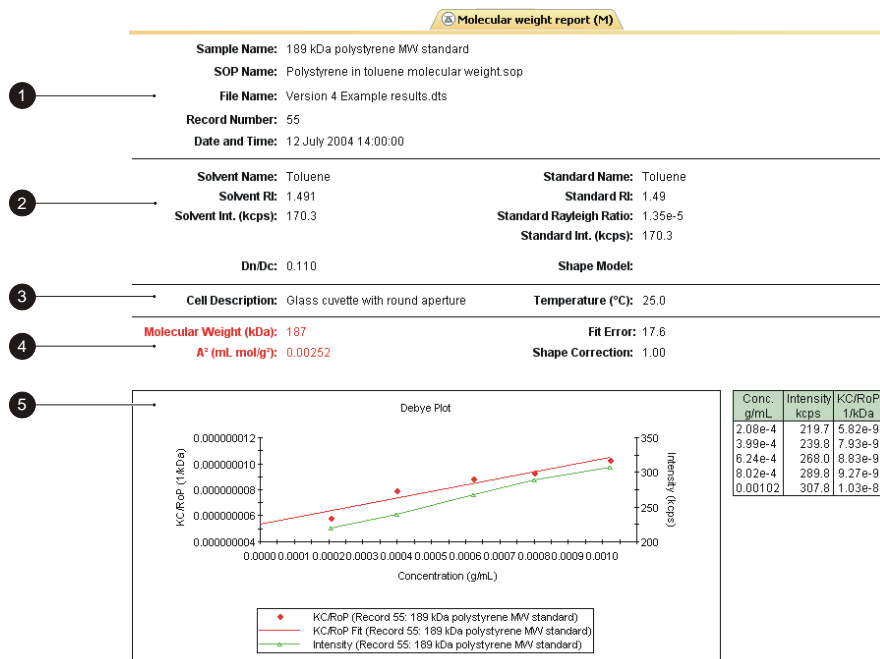

ill 7795

The report is divided into five areas; these are described below.

①, ② Sample and measurement details

These two sections show measurement details and details of parameters relating to the sample. Please see the **size** description for details.

Settings specific for Molecular weight are:

■ Dn/Dc

This is the differential refractive index increment; the change in refractive index as a function of the change in concentration.

■ Shape model

Shows the shape correction model used for the measurement. With knowledge of the sample configuration it is possible to improve the result of the measurement by adding the value that most closely corresponds to the probable sample shape; i.e. sphere, coil, cylinder or no shape correction.

③ System details

The System section gives details on settings configured during the measurement process. Please see the **size** description for details about **Temperature**, and **Cell type**.

④ Results

The results section gives four pieces of information:

■ Molecular weight

Shows the measured weight of a molecule within the measured sample expressed in atomic mass units; indicated in KiloDaltons (KDa).

■ Shape correction

Displays the shape correction model used for the calculation as mentioned above.

■ Second Virial Coefficient (A_2)

A property describing the interaction strength between the molecule and the solvent.

■ Fit error

This is an indication of the quality of the measurement. The lower the fit error the better the measurement.

⑤ Graph

The results are also shown in graphical form. Please see the **size** description above for details on altering the graph.

Flow-mode measurements - Standard report

The Standard Flow-mode report, **Chromatogram Summary (M)**, gives the same information as seen in a standard size report, plus additional information relating to the flow duration and rate used.

The three main peaks in the measurement will also be shown, displaying the sample intensity, width, Molecular weight and start and end flow volumes.

Additionally a the flow trace result graph will be displayed. This can be viewed either in **Time** or **Volume**:

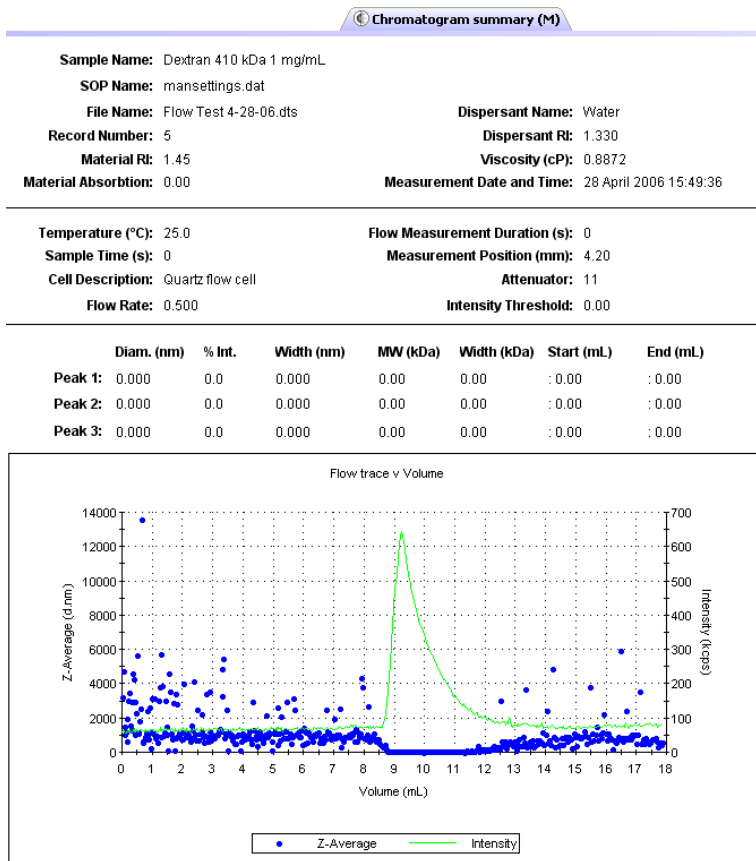

Trend measurements (including Protein Melting point)

Trend measurements can be viewed using the reports: **Trend**, **Trend v Custom 1** and **Trend v Custom 2** reports. Melting point trend measurements can be viewed using the **Melting point (M)** report.

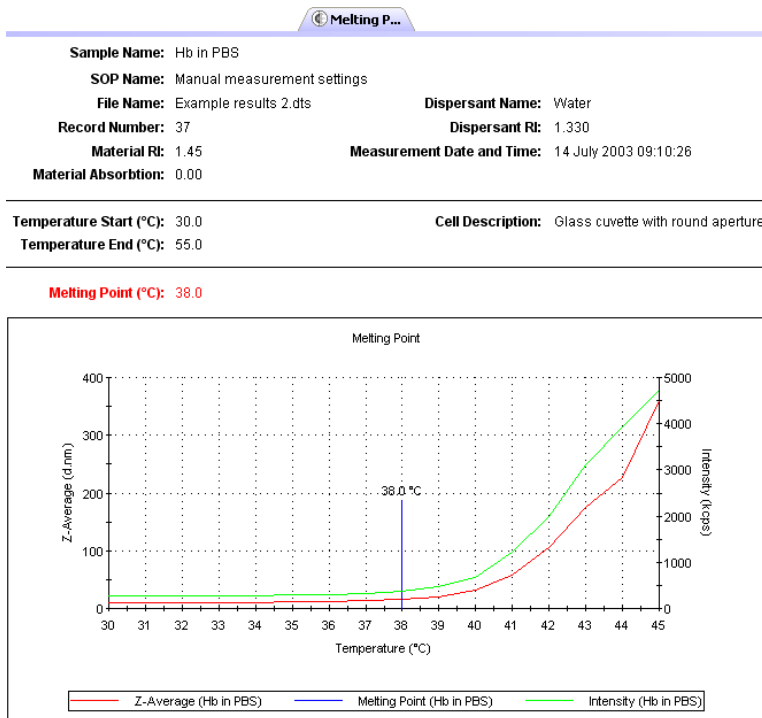

A trend report gives the same information as seen in a standard size or Zeta report, plus a graph showing the trend progression.

Additionally a melting point report will show the following:

Trend Temperature Start (°C)

The temperature defining the beginning of the measurement.

Trend Temperature End (°C)

The temperature that the measurement will end at.

Melting point (°C)

The temperature at which the melting point is achieved.

Sample Preparation

Introduction

Before filling the cell or cuvette that will be used in the measurement, the sample will need to be prepared. To ensure reliable and accurate measurements proper sample preparation is extremely important.

Preparation of the sample for the different measurement types will involve specific preparation techniques. For each measurement type follow the guidelines described.

Preparing the sample - Size

Consideration must be given to the physical properties of the sample such as its particle or molecular size and sample concentration. This section outlines the basic considerations for sample preparation.

Sample concentration

Each type of sample material has its own ideal range of sample concentration for optimal measurements.

- If the sample concentration is too low, there may not be enough light scattered to make a measurement. This is unlikely to occur with the Zetasizer except in extreme circumstances.
- If the sample is too concentrated, then light scattered by one particle will itself be scattered by another (this is known as multiple scattering).

An important factor in determining the maximum concentration the sample can be measured at, is the size of the particles or molecules.

Considerations for small particles

Minimum concentration

For particle sizes smaller than 10nm, the major factor in determining a minimum concentration is the amount of scattered light that the sample generates. In practice, the concentration should generate a minimum count rate of 10,000 counts per second (10kcps) in excess of the scattering from the solvent. As a guide, the scattering from water should give a count rate in excess of 10kcps.

Filtration

All liquids used to dilute the sample (and solvents) should be filtered before use to avoid contaminating the sample. The size of the filter will be determined by the estimated size of the sample. If the sample is 10nm, then 50nm dust will be an important contaminant in the solvent.

Samples are not filtered if at all possible. Filters can remove sample by absorption as well as physical filtration. Only filter the sample if aware of larger sized particles, such as agglomerates, that need to be removed as they are not of interest, or cause result variations.

Using ultrasonics

Ultrasonication can be used to remove air bubbles or to breakup agglomerates - however, this must be applied carefully in order to avoid damaging the sample. Limits for the use of ultrasonication in terms of intensity and application time are strongly sample dependent. Some materials can even be forced to aggregate using ultrasound.

Emulsions and liposomes should not be ultrasonicated.

Preparing the sample - Molecular weight

Preparation of a Molecular weight sample is similar to that followed for a size sample, though there are other aspects to consider.

The technique is very sensitive to dirt or dust in the sample and therefore great care is required in sample preparation. All solvents must be filtered to $0.02\mu\text{m}$ or better several times, and the prepared solutions allowed to stand for a period dependent upon the sample, this may be over 24 hours, to several days to ensure adequate solvation. All glassware and apparatus **must** be rigorously clean and free of scratches. Preparation of samples and storage of apparatus in a laminar flow cabinet to ensure minimisation of dust contamination is strongly recommended. Failure to carry out these routine procedures are certain to end in a poor or wrong result.

Very small samples such as proteins in aqueous solutions will often require filtering.

A number of concentrations of the sample must be prepared (typically 0.25 to 1 g l^{-1}). The polymer must be fully soluble and dust must be excluded.

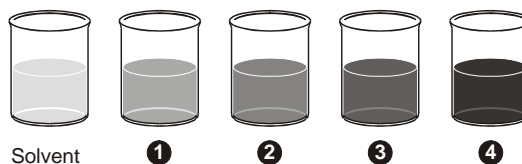

ill 6766

Increasing sample concentration →

The solvent scattering is measured followed by the various concentrations of sample. From these measurements a Debye plot can be generated.

This is a plot of the variation in average intensity versus the concentration. The intercept of the extrapolation to zero concentration is calculated.

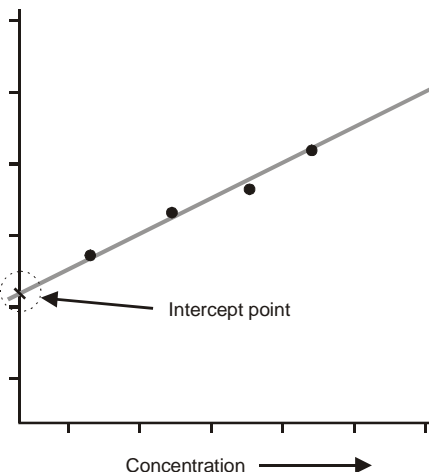

ill 6767

Concentration →

Minimum concentration

The minimum concentration of sample that should be used is defined by the excess scattering over the solvent which should be a minimum of 30%, e.g. If the solvent is toluene with a count of 150 Kcps then the lowest sample concentration should be greater than 150×1.3 kcps (195Kcps). Careful sample preparation procedures can make it possible to measure a sample with only 10% excess scattering but this is not ideal.

Maximum concentration

The APD detector used in the instrument has a linear operating range. Therefore the maximum sample concentration should give a count rate of less than 1000Kcps.

Count rate meter

After preparing the sample, the count rate can be checked by using the count rate meter. Selecting **Tools-Count rate meter** will display the following dialogue.

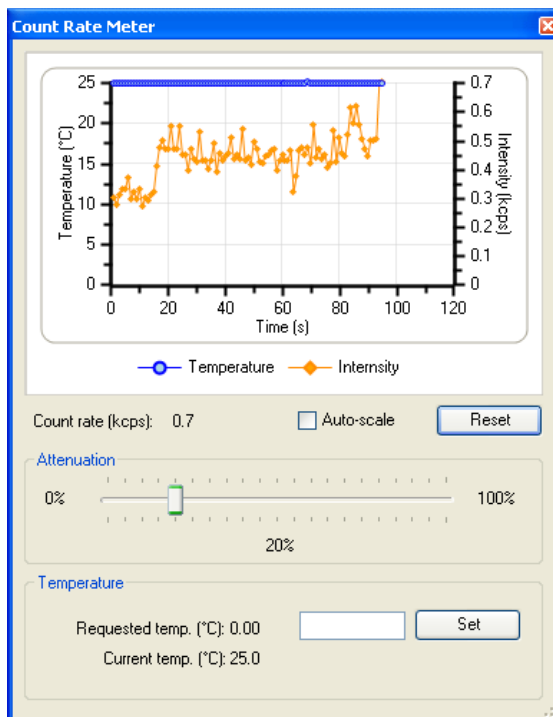

The **Count rate** is displayed in **Kcps** (Kilo counts per second), and enables the sample quality and concentration to be checked without having to start a measurement.

Count rate monitor

By inspecting the count rate monitor the quality of the sample can be observed. Selecting the **Auto Scale** check box will automatically scale the graph as the count rate monitoring progresses. **Reset** will delete the current display.

- **Normal count rate**

The monitor will show a relatively stable count rate.

- **Dust in the sample**

If dust is present then sharp spikes will be observed. Measurement runs with dust present will be removed from the final measurement calculation by a dust filtration algorithm unless all measurement runs contain spikes from contaminants.

- **Drifting count rate**

This may indicate that thermal gradients are present in the sample, and further time is required for temperature equilibration.

- **Increasing/Decreasing count rate**

A steadily increasing count rate will indicate an aggregating sample, while a decreasing count rate will indicate a sedimenting sample.

In addition to displaying the count rate, the dialogue allows changes to the cell and attenuator position settings. For normal operations both will be at the default setting.

Attenuator

The Attenuator setting can be used to monitor the scattering intensity without having to start a measurement.

- To change the attenuator position, alter the value using the slider bar.

Part 2 -

Supervisor's Guide

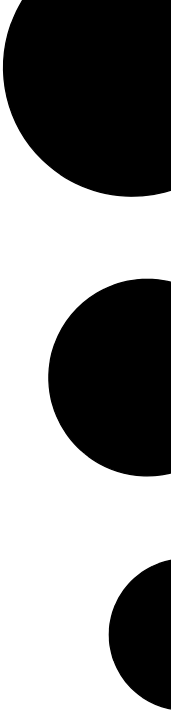

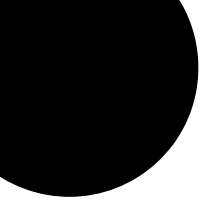

Security

Introduction

The systems may be used by users of varying skill levels. With the Zetasizer it is possible to limit user access so that certain functions such as editing SOPs, deleting records and editing results can be reserved for specific users only.

Within the Malvern **Security** system, one or more persons are set up as the administrator. The administrator then controls access to the instrument by defining “User groups” and “Permissions”.

- A **User group** is one or more persons that have the same access rights.
- **Permissions** are the access rights that are allowed for each user group, these will range from allowing SOPs to be edited to disabling view selection.

The administrator adds operators to a group and assigns each operator a password. Each operator’s identification and password are entered to enable access to the software.

The first time the software is run the security system will be disabled and an administrator user and administrators group will be created by the system. This is so at least one user will have permission to configure the security system.



Note

The Malvern security system can be upgraded to 21 CFR part 11 compliance by installing a “Feature key”. Once this is installed, 21 CFR part 11 security settings can be applied and ‘Audit trails’ can be viewed. If the feature key has been installed, the grey 21 CFR 11 icon on the status bar will turn to yellow. Please note that this manual will not detail the 21 CFR part 11 option but will concentrate only on the standard security software.

The first task is to set up the administrator account.

Initial start-up - set up the administrator

**Note**

It is vital that at least one user has access to the configuration of the security system.

Select **Security-Configure Security**.

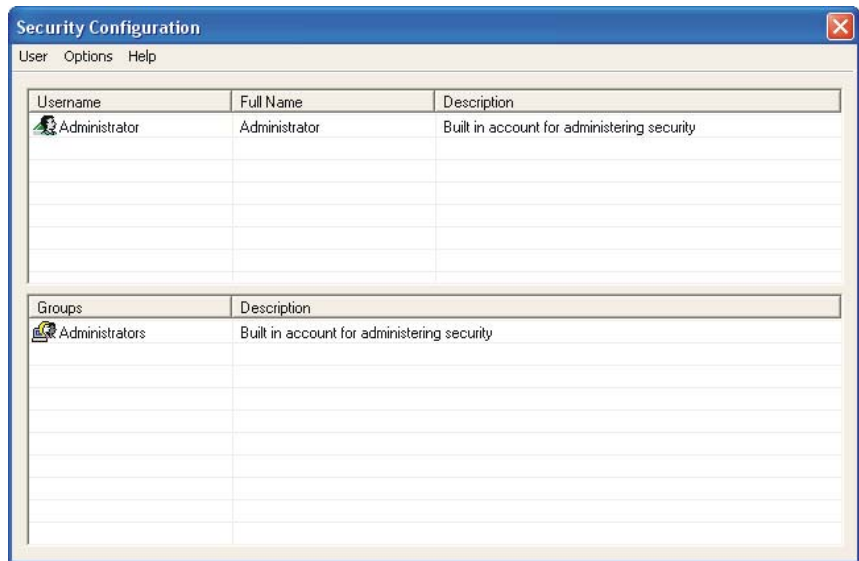

The first time the system is run, there will be just one user (Administrator) and one group (Administrators). This group is originally set to only allow configuration of the security system and to deny access to all other features of the system.

On first start up of the software the security system defaults to a member of the Administrators group with no password.

To secure the system, a password must first be specified for the administrator account (detailed later) and then the security enabled using the **Options-Security settings...** menu.

**Note**

It is preferable to have at least two users assigned to the Administrators group. The users user name and password should be stored in a secure location. This is to safeguard against accidental lockout or deletion of permissions that may prevent the security settings being available.

Remember that after any changes to the security system - adding users, changing of permissions, etc. The new changes must be saved (**User-Save**). A dialogue will appear on exiting to give a reminder on saving changes.

Enabling security

Within the **Security configuration** dialogue select **Options-Security settings** and select the **Enable security** check box.

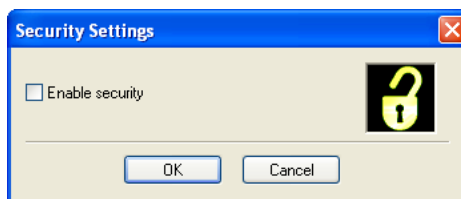

With security enabled each user must login when the software starts. Once logged in only their relevant permissions will be accessible, all other functions will be greyed out.

**Note**

With the 21 CFR part 11 feature key installed a different dialogue will be displayed. Once 21 CFR part 11 security is enabled it cannot be disabled.

To change operators when the software is already open select **Security-Logout** and then **Security-Login** and enter the appropriate passwords.

User groups



Note

Only users assigned to the Administrator group can add or edit the user group properties.

Adding/editing a group

Select **Security-Configure security** to enter the **Security configuration** dialogue. Select **User-New Group...** to display the **Group Properties** dialogue, alternatively double-click on an empty row. When editing double-click on an existing group to display the dialogue.

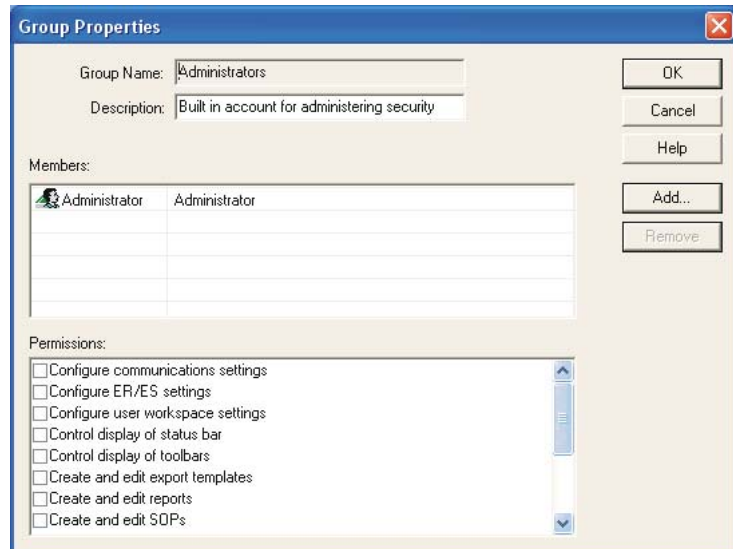

Enter a **Group name** and a **Description** of the group's purpose. Example names might be:

- **Operators** - General users of the system.
- **Supervisors** - Skilled operators responsible for configuration and SOP creation.
- **Administrators** - Users authorised to configure the security system.

The **Members**' section of the dialogue shows a list of all the users currently assigned to the group. To add a user press **Add** and a list of all users not currently

allocated to that group will be shown. Selecting one or more users (hold down the control key to select multiple users) and press **OK** to add those users to the group.

To remove a member, simply select the member and press the **Remove** button. Note that members are only removed from the group, they are not removed from the system.

The **Permissions** section of the dialogue allows functions of the software to be enabled/disabled for the group. To set the access permissions for the group, simply scroll down the list of permissions and check the boxes for the permissions required. This can also be done with a mouse or by highlighting a permission and pressing the space bar. The permissions list can be navigated using the up and down keys.

Users



Note

Only users assigned to the administrator group can add or edit user properties.

Adding/editing a user

Select **Security-Configure security** to enter the **Security configuration** dialogue. Select **User-New User...** to display the **User properties** dialogue, alternatively double-click on an empty row. When editing double-click on an existing user to display the dialogue.

A screenshot of the 'User Properties' dialog box. The dialog has a blue title bar with the text 'User Properties' and a close button (X) on the right. The main area contains several text input fields: 'Username:' with the value 'Administrator', 'Full Name:' with 'Administrator', 'Description:' with 'Built in account for administering security', 'Password:' with '*****', and 'Confirm password:' with '*****'. To the right of these fields are three buttons: 'OK', 'Cancel', and 'Help'. At the bottom, there are two unchecked checkboxes: 'User Must Change Password at Next Logon' and 'User Cannot Change Password'. A 'Groups...' button is located to the right of the second checkbox.

Each user must have a unique **Username**. This, along with the user **Password**, forms the unique key required to identify each individual using the system. The

Username is commonly an abbreviated form of the individual name or a unique identifier such as an employee code.

The **Full Name** is used to hold the full printed name of the individual and can be used on reports to identify the user if an employee code is used as a **Username**.

The **Description** field is optional and is just used to add some descriptive text to the user details.

Generally it will be the administrator entering these details. The administrator can enter the password but this would require the administrator to know a users password beforehand. A more secure approach is for the administrator to specify a previously arranged password, such as the user's name, and force the user to change their password the next time they log on using the password check boxes.

Press the **Groups** button to allocate the user to the required groups. Use the **Add** and **Remove** buttons to allocate the group(s) appropriate.

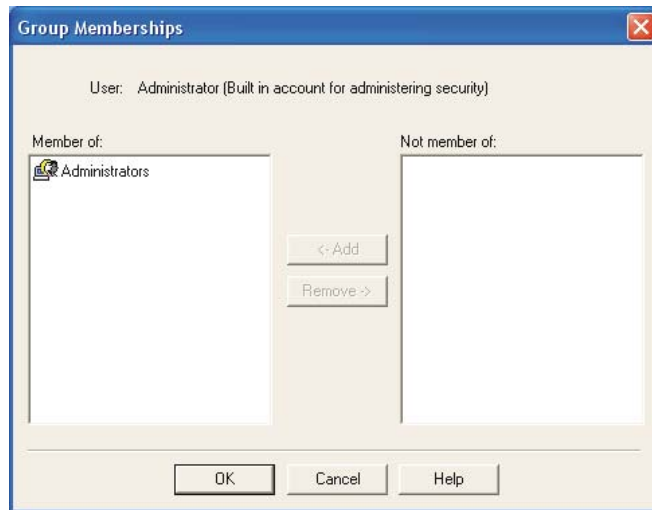

Password options

- **User must change password at next logon**

The change password dialogue will be shown when the user next logs in, allowing the user to change their password. This allows the security administrator and a user to set up a user account without the administrator knowing the users final password.

Users can change their own passwords once logged in by using the **Security-Change password** menu.

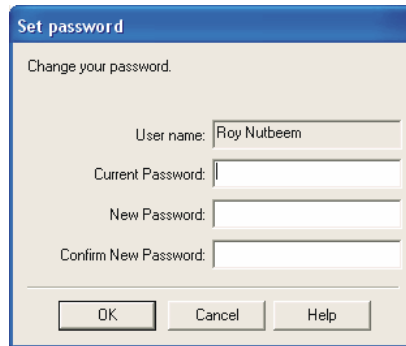

The image shows a 'Set password' dialog box. The title bar is blue and contains the text 'Set password'. Below the title bar, the text 'Change your password.' is displayed. There are four input fields: 'User name:' with the text 'Roy Nutbeem', 'Current Password:', 'New Password:', and 'Confirm New Password:'. At the bottom of the dialog are three buttons: 'OK', 'Cancel', and 'Help'.

To change the user password, enter the current password and specify a new password with confirmation. Pressing **OK** makes the change to the security settings.

■ **User can not change password**

This option prevents a user from changing a password once it has been initially set.

For a secure system, it is advisable for users to regularly change their passwords to prevent unauthorised access. The only possible exception is the security administrator's account where forgetting the password to this account could prevent any further configuration of the security system.

Measurement file window - Workspaces

Introduction

The **Measurement File window** is where all results (or records), and reports for each measurement file can be viewed, moved and analysed. Depending upon the **Window** options set, multiple measurement files can be viewed at the same time.

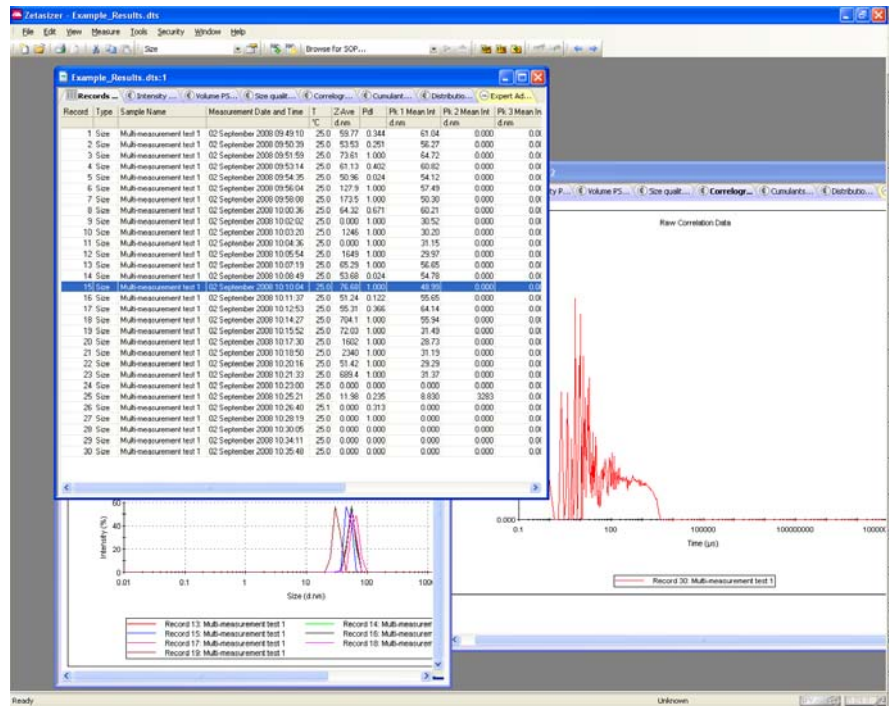

Once a result has been calculated, the data can be displayed as either a record or report - by selecting the appropriate tab.

Malvern provides several default reports (identified with (M) in the name) that will be sufficient for most users. The user also has the ability to create their own custom reports to satisfy their individual needs. Details on creating custom reports (using **Report Designer**) are given in **Chapter 11**.

Generally a computer screen displays information in a landscape format while a printer uses a portrait format. To accommodate this, each report is generated in two formats - one for displaying the report on the screen, and another configured for a printer. It is possible for the screen and print formats to be configured to report different information. A report file has the extension **.pag**, and will hold both the screen and print variations. The report page files can be found in the **\Pages** folder.

Measurement file window

Initially a measurement file must be opened by selecting **File-Open**. Once a file has been selected, a measurement window will appear.

Record	Type	Sample Name	Measurement Date and Time	T °C	Z-Ave d.nm	Pdl	Pk. 1 Mean Int d.nm	Pk. 2 Mean Int d.nm	Pk. 3 Mean Int d.nm	Pk. 1 Area Int %	Pk. 2 Area Int %
1	Size	Multi-measurement test 1	02 September 2008 09:49:10	25.0	59.77	0.344	61.04	0.000	0.000	100.0	
2	Size	Multi-measurement test 1	02 September 2008 09:50:39	25.0	53.53	0.251	56.27	0.000	0.000	100.0	
3	Size	Multi-measurement test 1	02 September 2008 09:51:59	25.0	73.61	1.000	64.72	0.000	0.000	100.0	
4	Size	Multi-measurement test 1	02 September 2008 09:53:14	25.0	61.13	0.402	60.82	0.000	0.000	100.0	
5	Size	Multi-measurement test 1	02 September 2008 09:54:35	25.0	50.96	0.024	54.12	0.000	0.000	100.0	
6	Size	Multi-measurement test 1	02 September 2008 09:56:04	25.0	127.9	1.000	57.49	0.000	0.000	100.0	
7	Size	Multi-measurement test 1	02 September 2008 09:58:08	25.0	173.5	1.000	50.30	0.000	0.000	100.0	
8	Size	Multi-measurement test 1	02 September 2008 10:00:36	25.0	64.32	0.671	60.21	0.000	0.000	100.0	
9	Size	Multi-measurement test 1	02 September 2008 10:02:02	25.0	0.000	1.000	30.52	0.000	0.000	100.0	
10	Size	Multi-measurement test 1	02 September 2008 10:03:20	25.0	1246	1.000	30.20	0.000	0.000	100.0	
11	Size	Multi-measurement test 1	02 September 2008 10:04:36	25.0	0.000	1.000	31.15	0.000	0.000	100.0	
12	Size	Multi-measurement test 1	02 September 2008 10:05:54	25.0	1649	1.000	29.97	0.000	0.000	100.0	
13	Size	Multi-measurement test 1	02 September 2008 10:07:19	25.0	65.29	1.000	56.65	0.000	0.000	100.0	
14	Size	Multi-measurement test 1	02 September 2008 10:08:49	25.0	53.68	0.024	54.78	0.000	0.000	100.0	
15	Size	Multi-measurement test 1	02 September 2008 10:10:04	25.0	76.68	1.000	48.99	0.000	0.000	100.0	
16	Size	Multi-measurement test 1	02 September 2008 10:11:37	25.0	51.24	0.122	55.65	0.000	0.000	100.0	
17	Size	Multi-measurement test 1	02 September 2008 10:12:53	25.0	55.31	0.366	64.14	0.000	0.000	100.0	
18	Size	Multi-measurement test 1	02 September 2008 10:14:27	25.0	704.1	1.000	55.94	0.000	0.000	100.0	
19	Size	Multi-measurement test 1	02 September 2008 10:15:52	25.0	72.03	1.000	31.49	0.000	0.000	100.0	
20	Size	Multi-measurement test 1	02 September 2008 10:17:30	25.0	1602	1.000	28.73	0.000	0.000	100.0	
21	Size	Multi-measurement test 1	02 September 2008 10:18:50	25.0	2340	1.000	31.19	0.000	0.000	100.0	

The way the measurement information is displayed is dependent upon which tab along the top of the measurement file window has been selected.

- The first tab is always **Records view**; this tab lists all individual measurements contained in the opened measurement file.

The measurement file records can be chosen using standard Windows™ procedure. Either click a single record, or hold down **Shift** or **Ctrl** and choose either sequential or non-sequential records.

- Subsequent tabs are the **Report tabs** - the tab giving the name of the report viewed. To view a measurement as a report, first select the measurement, or group of measurements, in the records view tab and then select the appropriate report tab. The report tabs will be greyed out if no measurement is selected.

What measurement information is presented in the **Report** and **Record** tabs is controlled by the **Workspace** selection dialogues (below). The tabs can be configured to display either all the measurement file records and associated reports (i.e. Summary), or only those that are relevant to one measurement type (e.g. Size).

The following sections deal with the various aspects of the measurement file window. The sections will deal primarily with the **Workspace** selection chosen as **Summary**, as this will show a 'complete' measurement file.

Workspaces

Instead of the measurement file windows showing every single measurement, it is possible to customise the window views so that, for example, only Molecular weight measurements from that file are shown. Similarly a user can create a personalised workspace so that only parameters and reports relevant to them will be shown.

Initially only the workspaces shown in the **Workspace Toolbar** menu (below) are available, all with **Record view** parameters and **Report pages** already configured.

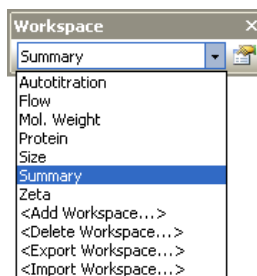

- Workspaces can be **selected** using the **View-Workspaces** menu option or the Workspace toolbar.
 - Workspaces can be **managed** using the **Tools-Settings-Configure Workspace** menu option or the Workspace toolbar.
 - The workspace toolbar can be turned on and off by selecting **View-Workspaces-Workspace Toolbar**.
- ▶ **To Displaying a Workspace**
- To **display** an **existing** workspace window, select **View-Workspaces-“..workspace choice..”** or use the **Workspace** toolbar (above).
- ▶ **To Create a new Workspace**
1. Select **Tools-Settings-Configure Workspaces-Add Workspace...** or select **<Add workspace>** from the toolbar.
 2. Type in a **Name** for the new workspace and press **OK**. This will display the **Workspace settings** dialogues.

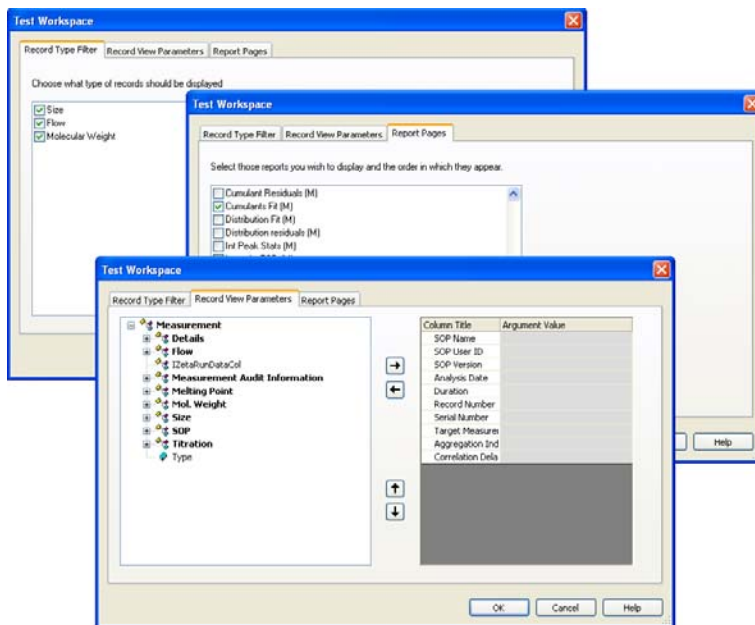

3. Use the **Workspace settings** dialogue to display what is required.
4. Use the **Record type filter** to display only specific measurement types in the **Record View**.

If only the size records are required, select **only** the **size** check box, and leave the Flow and Molecular weight unchecked.

If all three measurement types are selected, then all Size, Flow and Molecular Weight measurement records will be displayed.

5. Use the **Record view parameters** to specify what parameters will be viewed as the column headings.
6. **Report pages** allows selection of both Malvern created and customised reports.
7. When selected, click **OK**.

Once completed the new workspace can be selected using the **View** menu or **Workspace** toolbar.

► To Modify a Workspace:

1. Select the workspace name from the toolbar drop-down list (or from the **Tools-Settings-Configure Workspaces** menu) and then click the **Configure** icon .
2. This will display the **Workspace Settings** dialogue for the selected workspace.

3. Alter the settings as required and press OK; the new settings will be saved.

Deleting a Workspace

Select **<Delete workspace>** from the toolbar or the **Tools-Settings-Configure Workspace** menu.

From the list, select the workspace to be deleted and click **OK**.

Exporting and Importing Workspaces

Workspaces can be exported to, and imported from, folder locations by using the **<Export workspace>** and **<Import workspace>** options in the toolbar and **Tools** menu.

To export a workspace

First select the workspace to be exported, and then select **<Export workspace>**, In the dialogue that appears, select the destination folder and save the workspace. The workspace will be saved as a **.zwrk** file.

To import a workspace

Select **<Import workspace>**, browse for the folder and select the workspace. Press **Open** and then **OK** to display the new workspace.

Record view

With the **Summary** workspace selected, the default parameters displayed when the software is first installed are: **Record, Type, Sample Name, Measurement Date and Time, T** (Temperature), **Z-Ave, PDI, MW** (Molecular weight) and the **Result Origin**.

For each workspace the record view can be customised by adding or removing any of the parameters that are stored with the measurement record. The order in which the parameters are displayed can also be rearranged.

Adding and deleting a parameter in the record view

The **Record View Parameters** dialogue is accessed by selecting **Configure-Workspaces-“..workspace choice..”** and then the **Record View Parameters** tab.

The list on the left displays all parameters available for a measurement record. The list on the right displays all parameters that are currently displayed in the **Records view** and the order in which they appear.

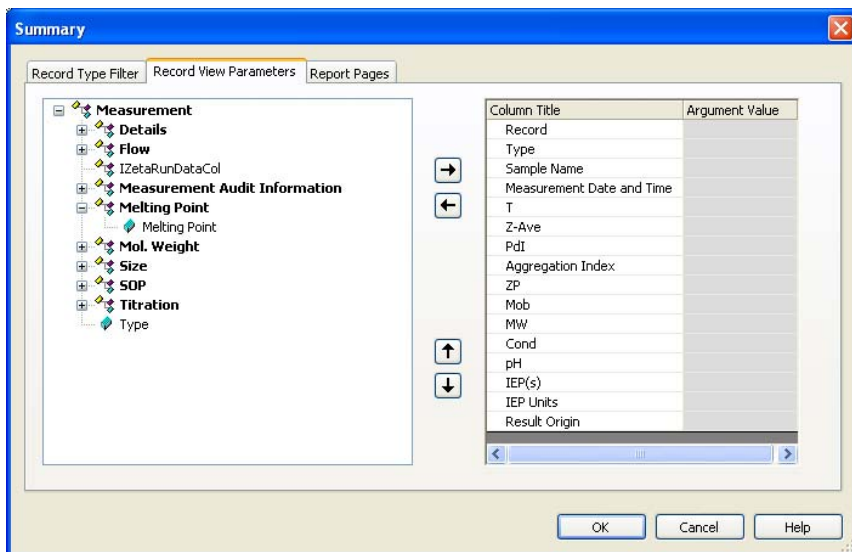

Parameters can be added or removed from this list by using the **Add** and **Remove** keys  .

Change the order in which the parameters are displayed by selecting a parameter, and pressing the **Move up** or **Move Down**  buttons.

Press **OK** to exit and return to the **Records view**.

Parameters with arguments

Certain parameters allow specific values (or arguments) to be added.

- A Dv(90) percentile can be viewed by adding **Measurement-Size-D(v)** and then typing 0.90 as the argument value.
- Column titles can be altered by double-clicking on them e.g. double-click on D(v) and alter to Dv(90) to reflect the particular percentile size viewed.

Record Number	
Type	
Sample Name	
Measurement Date	
Temperature (°C)	
Dv(90)	
D(v) argument (0 to 1)	0.90



Note

If the software is subsequently updated with a new version, the changed parameter names will be preserved.

Report tabs

The report tabs show every report that has been selected for a workspace. With the **Summary** workspace selected the default reports are **Intensity PSD (M)** and **Molecular weight (M)**. These and other reports can be added or removed using the workspace dialogues.

Selecting a report to view

Select **Tools-Settings-Configure Workspace-** “..workspace choice..” and then the **Report Pages** tab.

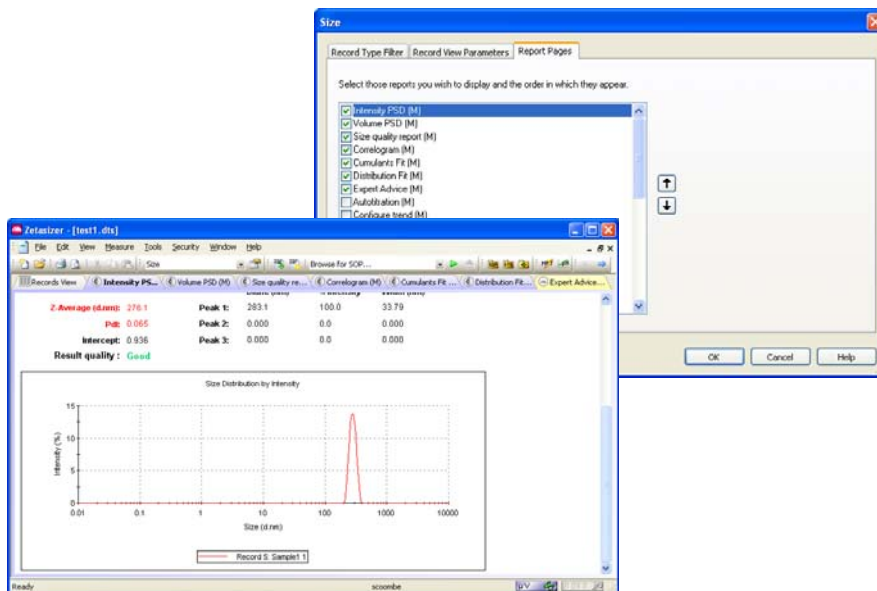

Select the check box of the required reports and press **OK**.

Use the **Move up / Move down**   buttons to alter the screen order of the viewed reports.

Any reports created with **Report Designer** will automatically be added to the list.

Handling the measurement files

In the **Records view**, depending upon the workspace settings chosen, all measurement records for that file will be shown. It is possible within the **Records view** to move, delete and copy individual records in the measurement file window or between different files, plus the ability to edit the result.

Moving, Copying and deleting records

There are several ways to handle the information.

- One or more records can be copied from a **Records view** tab and “dragged and dropped” directly into another open measurement file.

Select a record then move the cursor slightly towards the edge of the selection until a small rectangle and plus sign attaches. Press the mouse button down and ‘drag’ the selected record(s) to the other file, then ‘drop’ - release the mouse button.

- A record can also be copied by selecting the item then selecting **Edit-Copy**. The item can then be pasted into another file (**Edit-Paste**).
- Selecting **Edit-Delete** will instantly remove any selected records from the measurement file. They will not be deleted from the software, but be stored in a **.del** file in the **My Documents\Malvern Instruments\Zetasizer\Measurement Data** directory. This file has the same name as the original measurement file but with a **.del** extension. If required the deleted records can be copied back to the original file. Use the Windows file manager to delete the complete **.del** file.

Records can be selected by either clicking the cursor on the required record, or by using the **Navigation** toolbar - press the arrows to move up and down the record list.



Sorting

Records in a measurement file window can be sorted into alpha-numeric order.

For example, In record view click on the **Measurement Date** header to list all records into numeric “measured date” order. Click on the column header again to toggle between ascending (∇) and descending order (Δ).

Batch printing

To immediately print reports from more than one record choose the required measurement records, and select **File-Batch print...** The **Batch print** dialogue will appear, requesting which report template to print out.

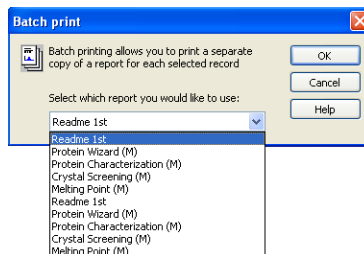

Using SOPs

Introduction

An SOP measurement uses pre-set parameters, to ensure that measurements made on the same type of sample are made in a consistent way. SOPs are ideal if repeatedly measuring the same type of sample. Having to set the same parameters each time a measurement is made is tedious and also adds the risk of introducing errors into the settings - using SOPs avoids this.

Chapter 4 gave instructions on how to use an SOP to make measurements, but this assumes that an SOP already exists for the sample to be measured. If no SOP exists for the sample then one needs to be created; there are three ways to do this:

- Create a new SOP by using the SOP creation wizard - see **Creating an SOP** below.
- Create a new SOP by editing an existing one - see **Modifying an SOP** later in this chapter.
- Optimise the measurement settings by making manual measurements, then **extract the SOP** from the record and save it.

This chapter focuses on how to create a new SOP and details all the measurement settings that are available. Almost all the options for creating an SOP are the same as those available for making a manual measurement, so this chapter will also help those who require an explanation of the options available for a manual measurement.

As well as describing the SOP creation for the three major measurement types (size and Molecular weight), it is also possible to create SOPs for **Trend** and **Melting point** measurements. These will be described towards the end of this chapter as they generally use the same SOP dialogues as those described for the major measurement types.

Once a measurement has been completed it will be added to the list in the **Records view** tab of the **Measurement file** window. The SOP used can be viewed by right-clicking over the measurement record and selecting **Extract SOP**.

In each of the SOP dialogues there are **Help** or **Advice** buttons that will advise on how to complete the SOP.

SOP Player

The **SOP player** is a stand alone dialogue that enables a sequence of **actions** - SOPs, measurements, pauses or macros - to be constructed and then played. This sequence is called a **playlist**.

This is useful for performing different measurements types consecutively without any user interaction; i.e. performing size and Zeta measurements in sequence with appropriate pauses, or macros.

An example application for using the SOP player is a **Temperature trend with titration measurement**:



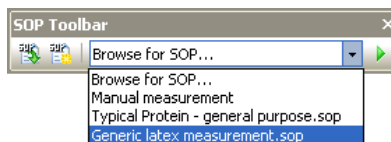

- i.e. increase the temperature of a sample - measure,
- add some titrant - measure,
- decrease the temperature - measure,
- and repeat.

SOP Toolbar

The **SOP Toolbar** looks like this:



The **SOP toolbar** allows three functions to be performed.

- Selecting the **New SOP**  icon from the toolbar. This will open a new SOP.
- Selecting the **Existing SOP**  icon from the toolbar. This will open an existing SOP.
- The **SOP toolbar browser**   allows an SOP that has been created specifically for a particular type of measurement to be easily selected. This is done by selecting the SOP from the drop-down list and pressing the  icon. The measurement will now start without first showing the SOP editor.





Alternatively if **Browse for SOP...** is selected and the  icon is pressed. The SOP directory will be displayed where an SOP can be manually selected.

The title of the SOP shown is that typed into the **Sample name** entry box in the **Sample** SOP dialogue. Ensure a suitable name is chosen that will identify the measurement has been created to perform.

The drop-down list can show a maximum of seven SOPs. This will always include **Browse for SOP**, **Protein measurement** and **Manual measurement**, plus the last four SOPs used. The last four SOPs will also be shown in the **Measure** menu.

The SOP Editor

The **SOP Editor** will appear if any of the following is performed.

- Selecting **File-New-SOP** from the Menu bar. This will open a new SOP.
- Selecting the **New SOP**  icon from the toolbar. This will open a new SOP.
- Selecting **File-Open-SOP** from the Menu bar. This will open an existing SOP.
- Selecting the **Existing SOP**  icon from the toolbar. This will open an existing SOP.
- Selecting a measurement record, then selecting **Edit-Extract SOP** from the Menu bar. This will open the SOP editor. (The title bar will show **Extracted SOP Settings**) so a measurement's SOP settings can be viewed. If altered, the new settings can be saved by using **File-Save** or pressing the **Save icon** .
- Right-clicking on a measurement record and selecting **Extract SOP**. (see the above description).
- Selecting **Measure-Manual** from the Menu bar. This will open the SOP editor (the title bar will show Manual Measurement) where all settings can be configured **immediately** before starting a measurement. Once configured, the settings can be saved as an SOP by using **File-Save as** or pressing the **Save as icon** .
- Using the **SOP search** facility in the SOP toolbar (on the main software application). See the **SOP Toolbar browser** description on previous page. Depending upon choice, this will show an SOP that is already configured for a specific measurement.

Tree menu view

On opening the SOP editor the window below will be displayed; the exact list displayed will depend upon the **Measurement type** selected. The SOP dialogues available for each measurement type will be displayed down the left hand side of the window, with the respective highlighted SOP dialogue shown alongside. The dialogue will alter as each SOP dialogue is selected.

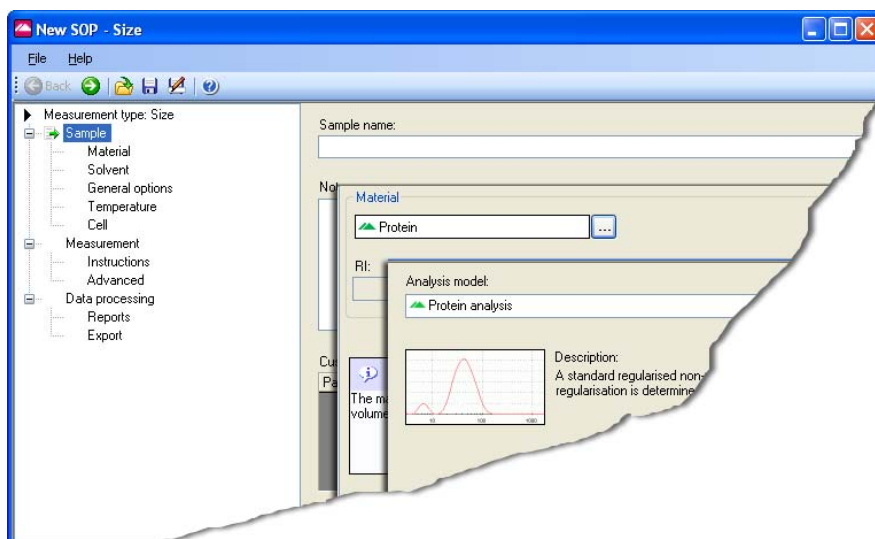

Note

Always select the Measurement type first when editing an SOP otherwise any changes will not apply.

The dialogues can be stepped through by using the  navigation buttons, the **up** / **down** keys on the keyboard, or selecting directly from the record list.

Most of the SOP dialogues are common to all measurement types; other SOP dialogues are **unique** to the **measurement type** selected and are discussed in individual **Size**, **Molecular weight**, **Flow** and **Trend SOP** sections.

Throughout the SOP dialogues some parameters will be available with an option to change the units used in their description. For example, Temperature has the option to use either **°C** (Celsius) or **K** (Kelvin). For all parameters where this option applies a scroll down list will be available alongside the parameter. The Parameter unit chosen will be displayed in the final results and reports.

The SOP dialogues available are:

Measurement type

Allows selection of the type of measurement that the SOP will perform, i.e. **Size**, **Protein melting point**, **Molecular weight**, **Flow** or **Trend**.



Note

It is important that the **Measurement type** is the **first** parameter that is selected, as all subsequent settings will be related to this measurement type.

Sample

This dialogue allows the measurement record to be named. All measurements made using this SOP are given the sample name entered in the SOP by default, but you can give an option to change this when you make the measurement. Information can be entered in the **General notes** box, such as a batch number.

This is a common dialogue for **all** SOPs.

Sample - Material

This dialogue allows the physical properties of the sample **material** to be set. The refractive index and absorption can be entered for the material used.

This is a common dialogue for **all** SOPs with unique features dependent upon the measurement type.

Sample - Solvent

This dialogue allows the physical properties of the sample **solvent** to be set. The refractive index and viscosity can be entered for the dispersant used.

This is a common dialogue for **all** SOPs with unique features dependent upon the measurement type.

Sample - Standard

This dialogue allows the physical properties of the standard that will be used for Molecular weight measurements to be set. The Refractive index and Rayleigh ratio can be entered for the standard used.

This is a unique dialogue for **Molecular weight** SOPs.

Sample - General Options

This dialogue allows additional physical properties of the sample that will be used to be entered.

This is a common dialogue for **all** SOPs with unique features dependent upon the measurement type.

Sample - Temperature

This enables selection of the temperature at which the measurement will be performed.

This is a common dialogue for **all** SOPs **except** Trend and Protein melting point.

Sample - Cell

This dialogue allows selection of the cell to be used.

This is a common dialogue for **all** SOPs.

Measurement

This dialogue allows the duration of the measurement to be set, and to make multiple measurements of the same sample.

This is a common dialogue for **all** SOPs with unique features dependent upon the measurement type.

Measurement - Instructions

This enables instructions on preparing and measuring the sample to be shown before and after each measurement. This dialogue is not available when performing a manual measurement.

This is a common dialogue for **all** SOPs.

Measurement - Advanced

Use the **Advanced** dialogue to alter the cell and attenuator position settings.

Measurement - Flow settings

Enables the flow rate of the sample through the instrument and connecting tubing to be entered.

This is a unique dialogue for **Flow** SOPs.

Data Processing

If characteristics are already known about the sample being measured, this dialogue will allow a more appropriate analysis model to be applied.

This is a common dialogue for **all** SOPs with unique features dependent upon the measurement type.

Data Processing - Reports

This dialogue enables reports to be printed automatically after each measurement and/or after a run of measurements has been completed. An option is also available to make PDF versions of the results (21 CFR part 11 feature key required).

This is a common dialogue for **all** SOPs.

Data Processing - Export

Enables the measurement results to be exported, as a text file, to third party software packages such as Excel or Wordpad.

This is a common dialogue for **all** SOPs.

Trend - Sequence

Enables the selection of the temperature trend parameters, i.e. start and end temperatures, and intervals between measurement steps.

This is a common dialogue for **Size** and **Zeta** trend measurements.



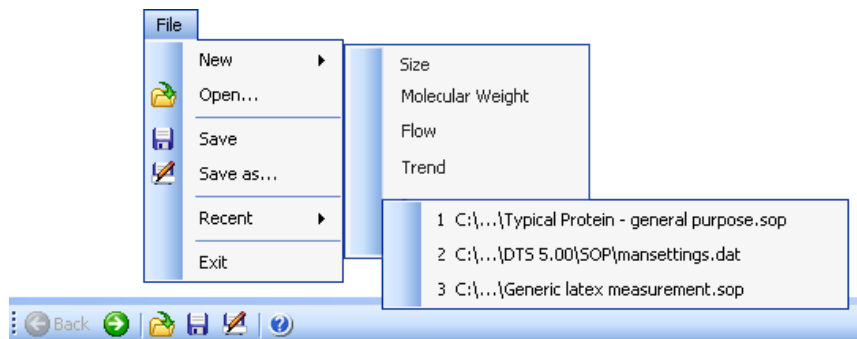

All SOPs are described in detail in the following sections.

SOP Editor Menu and Toolbar

SOP file management, saving and associated software functions are handled using either the Menu bar or the Toolbar.



The functions are described in the following table.

Menu item	Toolbar icon	Description of function
File-New		Opens a new SOP
File-Open...		Opens a existing SOP
File-Save		Saves the currently open SOP
File-Save as...		Saves the currently open SOP under a new name
File-Recent		Displays the three most recently used SOPs
File-Exit		Exits the SOP editor
Help Menu		Displays the Zetasizer software help menu



Use to move up and down the SOP tree menu. The SOP dialogue will alter to match the selection

Creating an SOP

- Select **File-New-SOP**. This will open up the **SOP Editor**.
- Select the **Measurement type** required (see next section).
- Change the settings within the SOP dialogues. These are described in the following pages under the Measurement type selected (e.g. Size SOPs).
- When all the SOP settings have been completed, select **File-Save** or press the **Save icon** , and enter a name, and save the new SOP.

Measurement type selection

The measurement type must first be selected before entering the settings on the subsequent SOP dialogues.

► To Select the Measurement type

- Left click on ► **Measurement type** and select the measurement type from the pull down menu.

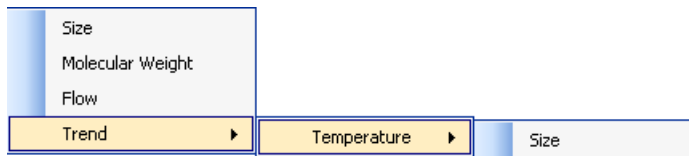

- The Measurement types are:

Size

Molecular Weight

Flow

Trend

Trend has a sub-menu where a temperature trend can be selected to measure against Size.

Melting Point measurements can be performed using the Trend measurement type.

- When selected, the content of the SOP tree menu changes to match the measurement type.



Note

The following **Size SOP** section describes the SOP dialogues shown when a **Size Measurement type** is selected. This **includes** all sizing SOP dialogues **and all** dialogues that are common to **all** SOPs. When requested in the Molecular Weight and other SOP sections refer back to the Size SOP section for a description of the dialogue.

Size SOPs

Though the majority of the **Sample** and **Measurement** dialogues described below are **unique** to **Size** measurements; this section also includes SOP dialogues that are **common** to **all** SOPs.

The **Size SOP Editor** menu is:

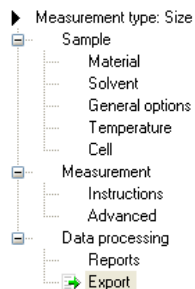

Sample

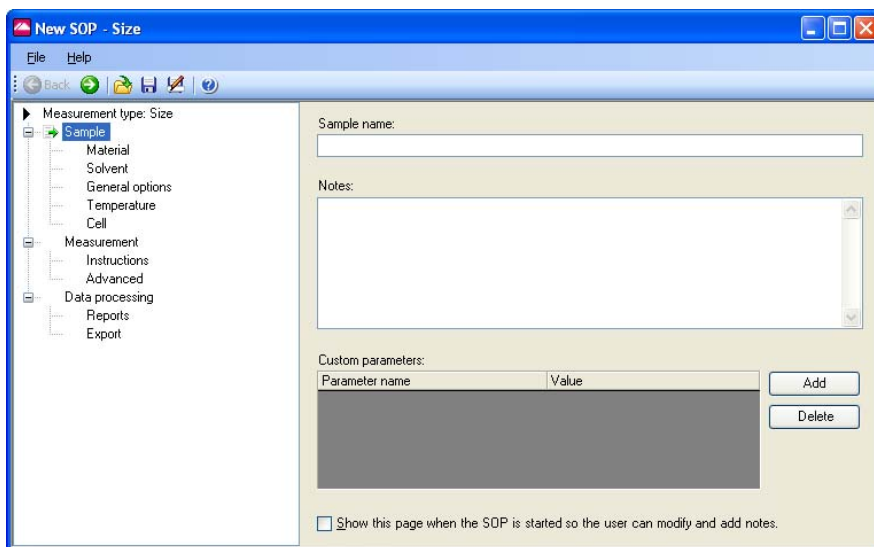

The components of the dialogue are:

Sample name:

The name entered here should be a description of the sample being measured. If no name is entered the sample name entry in the **Records view** will be left blank.

The name typed into the **Sample name** entry box will be displayed in the **SOP toolbar** browser. Ensure a suitable name is chosen that will identify the measurement the SOP has been created to perform.

Notes:

The general notes area allows comments about the measurement to be entered.

Note that any comments written during the SOP creation will appear in all measurement records that use the SOP unless the **Show this page when the SOP is started...** check box is selected and the text modified.

Custom parameters:

This function enables the user to manually enter a parameter at the beginning of a measurement, associated with the sample that is not measured by the system. This parameter is stored in the result record for subsequent use in result reports or for generating a trend plot using this parameter. For example the parameter could be the concentration of an additive which is varied in subsequent measurements, then plotted as a function of the size of the material, for example to study its effect.

Once in the record, the parameter will be available for selection for both the workspace and Records view, and for data export.

Adding a parameter (Add button)

To add each parameter, select **Add** and input the **customer parameter name**, i.e. Surfactant A. When the SOP is subsequently run, the SOP will request the addition of a value for the new parameter. By running the SOP a number of times with different input values, the resultant measurements can be subsequently plotted and any effects observed.

Show this page when the SOP is started...

With this check box selected the **Sample identification** dialogue will appear when the SOP is started. The user can modify the sample name and add or modify any comments about the measurement.

If this check box is not selected the measurement display will appear immediately when the SOP is started. To add comments, press the **Settings** button on the display.

Sample - Material

The Zetasizer software requires certain information about the physical properties of the dispersant that is used in the sample that is to be measured. Selecting the **Sample - Material** dialogue and pressing the button, displays the **Material properties manager** where these properties can be defined.

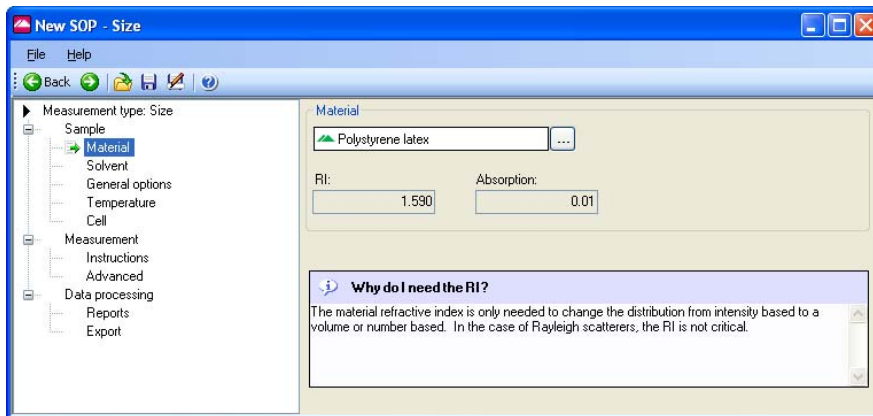

Materials Manager

From the list displayed, an available material can be selected from the list for inclusion in the SOP; alternatively a material can be added, modified or deleted from the list.

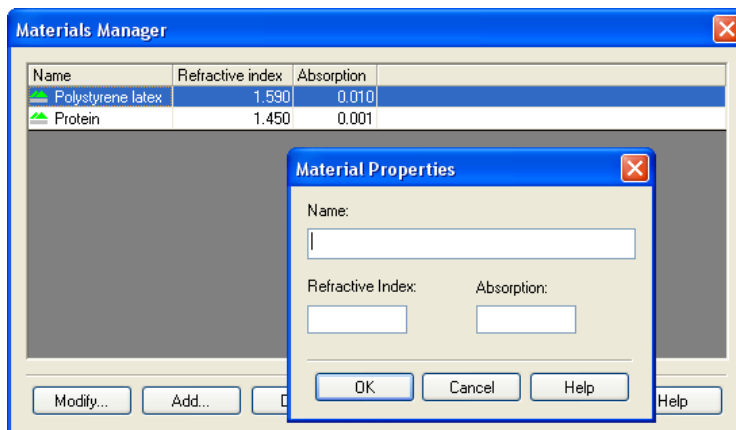

To define a new material, press the **Add...** button to display the **Material Properties** dialogue. Here, the material **name**, **refractive index** and **absorption** can all be specified.

The **Refractive index** and **Absorption** are only needed if the result is required as a volume distribution.

- The **Refractive index** can be obtained from a number of sources and is only required to two decimal places. Note that the refractive index is wavelength dependent.
- The **Absorption** is the quantity of light absorbed by the material when suspended in the dispersant. Generally clear samples will have a low or zero absorption while coloured or black samples will have a high value.

Example absorption values:	Emulsions :	0.00
	Latex :	0.01
	Coloured samples :	0.3
	Blue/black samples :	0.9

Other materials such as gold and silver colloids can have absorbance values greater than 1, and refractive index values less than 1.

Sample - Solvent

The Zetasizer software requires certain information about the physical properties of the dispersant that is used in the sample that is to be measured. Selecting the **Sample - Solvent** dialogue and pressing the button, displays the **Dispersants properties manager** where these properties can be defined.

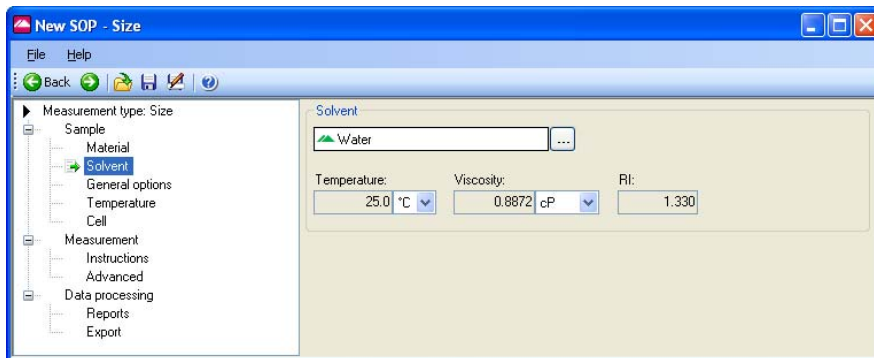

Dispersants Manager

From the list displayed, an available dispersant can be selected for inclusion into the SOP; alternatively a dispersant can be added, modified or deleted from the list.

To define a new dispersant, press the **Add...** button and choose from defining either a **Simple dispersant or solvent** or a **Complex solvent** - for details on defining a Complex solvent please refer to the **Solvent builder** section in **Chapter 10**.

On selection of a **Simple dispersant or solvent** the **Dispersant Properties** dialogue will appear, allowing new dispersants to be defined. The dispersant **name**, **refractive index** and **viscosity** can all be specified.

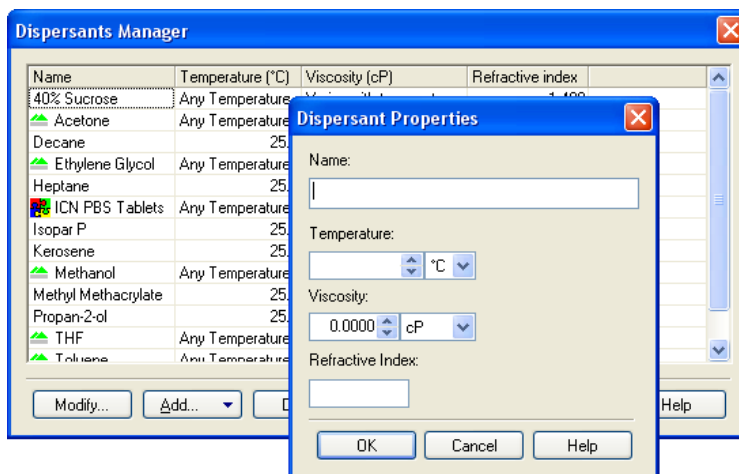

The viscosity can only be specified at a certain temperature. If the measurement is to be done at another temperature, then the viscosity value must be changed to match.

It is often more practical to find a value for viscosity at a particular temperature, and then change the temperature of the measurement to match. Alternatively create multiple dispersants with varying viscosity values, the dispersant name containing the temperature for that viscosity, e.g. Propanol 25C.



Note

Viscosity is temperature dependent. The Malvern defined dispersants include a built in viscosity calculation that determines the correct viscosity of the dispersant at any sample temperature.

To **modify** a dispersant, select the dispersant from the list and press the **Modify...** button (or double-click the dispersant in the list). The **Dispersant Properties** dialogue will appear, allowing the parameters to be changed.

A dispersant can be **deleted** by selecting the dispersant from the list and pressing the **Delete...** button.



Note

Note that it is not possible to modify or delete the dispersants that were specified by Malvern.

Sample - General Options

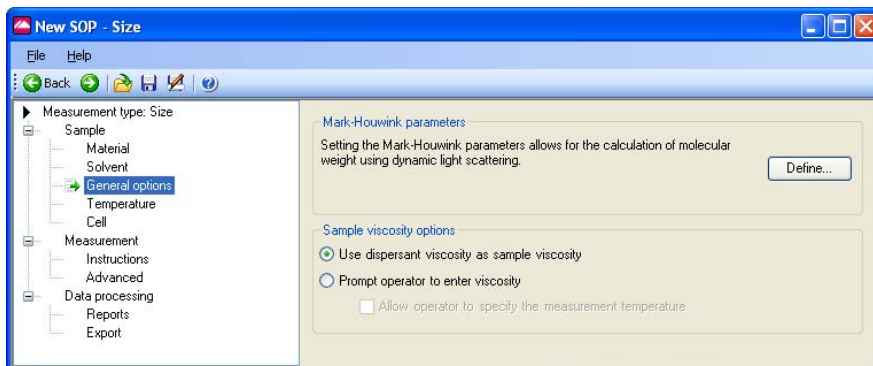

Mark-Houwink parameters.

Selecting the **Define** button displays the **Mark-Houwink parameters** dialogue.

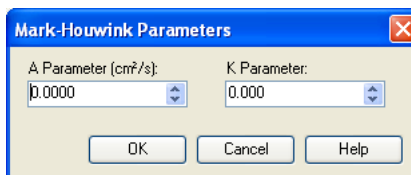

This allows the Mark-Houwink parameters to be entered to enable a Molecular weight to be calculated based on the dynamic light scattering data.

In the Mark-Houwink relationship: $D = kM^{-a}$

From knowledge of the Diffusion Coefficient D and the a and k constants (both available in many reference books and the help file), the Molecular weight M can be determined.

Once entered, both a Molecular weight calculation and Size measurement will be available for display.

Sample viscosity options

This area is useful for customising the viscosity parameters.

If working at low sample concentrations it may be useful to use the **dispersant viscosity as sample viscosity**. At high dilutions, the assumption that the sample viscosity is the same as the dispersant viscosity is usually valid. If this is not the case, or at higher sample concentrations (over 0.1%) then the sample viscosity should be measured and this value used.

If the viscosity of the sample is known only at certain temperatures select the **Prompt operator to enter viscosity** button. This allows the user to enter both the viscosity and the temperature, prior to the measurement being started.

Sample - Temperature

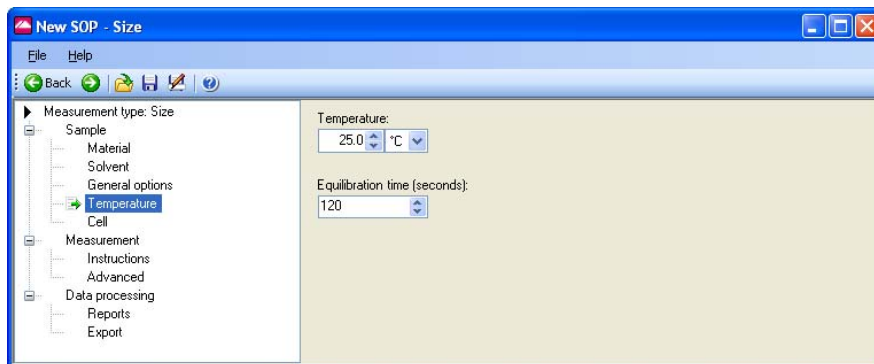

Note

The Zetasizer is capable of heating or cooling the sample to allow the measurement to be made at a specific temperature. The measurement will not start until the sample has reached the temperature specified.

Input the **Temperature** required, and how long the sample should be left to equilibrate before the measurement is started.

Equilibration time adds a delay before the start of each measurement to ensure the sample temperature is equal to the cell area temperature. The delay starts as soon as the instrument has reached the operating temperature requested. Allowing the sample to be fully temperature equilibrated ensures the Brownian motion of the particles is measured and not convection due to temperature gradients. If you find that the first result of a series of repeat measurements is different, try increasing the equilibration time.

Note that it takes time for the sample to reach the required temperature - the further away the required temperature is from current temperature, the longer it will take for the sample to reach a stable temperature.

Cell

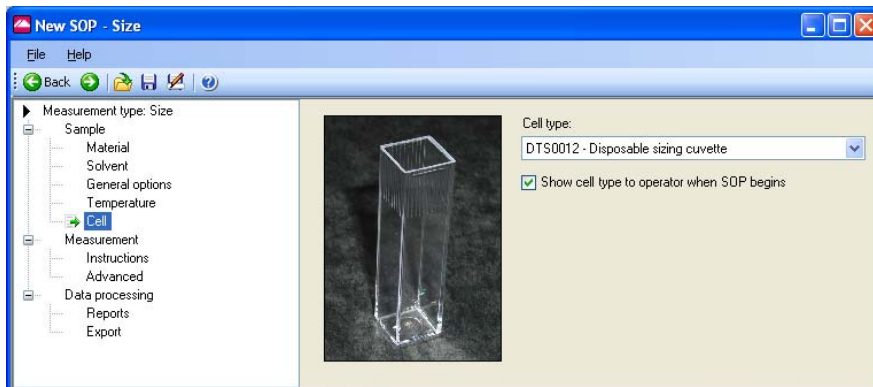

Select a **Cell type** from the drop down menu that matches the cell in which the sample is prepared. If required, select the **Show cell type...** check box to display a message to the operator reminding them of this cell type when the SOP is run.

Measurement

This dialogue allows the duration of the measurement to be defined, and to make multiple measurements of the same sample.

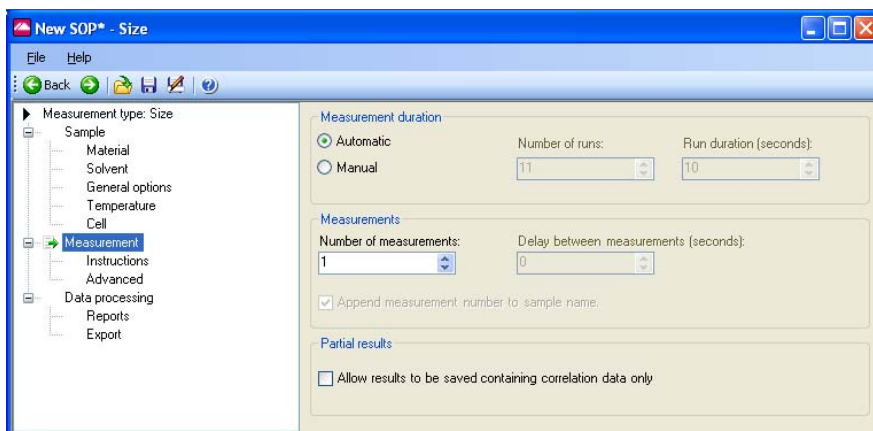

Measurement duration

The **Measurement duration** setting affects the accuracy and repeatability of the results.

With **Automatic** selected, the software automatically determines the most appropriate measurement duration. For most samples this can be left as the

default. Automatic measurements will be divided into a number of runs of at least 10 seconds in length.

Using **Manual** the time may be reduced for the measurement of a latex standard, or increased to improve the repeatability of the measurement of particularly polydisperse samples. Manual run durations can be set between 1 and 600 seconds, and the number of runs from 1 to 600. Longer measurement durations will increase the quality of data obtained and will generally give better results, as those runs that contain the poorest data will be rejected, with the remaining good runs used in the final measurement calculation.



Note

If repeat measurements with the **Manual** setting still show differences in the distribution with an increased measurement time then the sample preparation method should be reconsidered, as large particles may be disrupting the measurement.

Measurements

This option allows a sample to be measured more than once; to investigate the effect on Particle Size over time, or to prove repeatability. Set the **Number of measurements** to the required number. Add a delay between measurements in the **Delay between measurements** text box if required.

The **Append measurement number...** check box will append an incremental number, i.e. 1, 2, 3 etc, to the record name for each measurement made. The incremental number is reset back to 1 each time the SOP is started.

Partial Results

If it is likely that a measurement will not produce a correlation function that can be analysed - for example, measurement of a surfactant solution at lower than the critical micelle concentration - then the data collected can still be saved by selecting the **Allow results to be saved containing correlation data only** check box within the **Partial Results** area.

Measurement - Instructions

This dialogue allows instructions to the user to be displayed both before and/or after running an SOP.

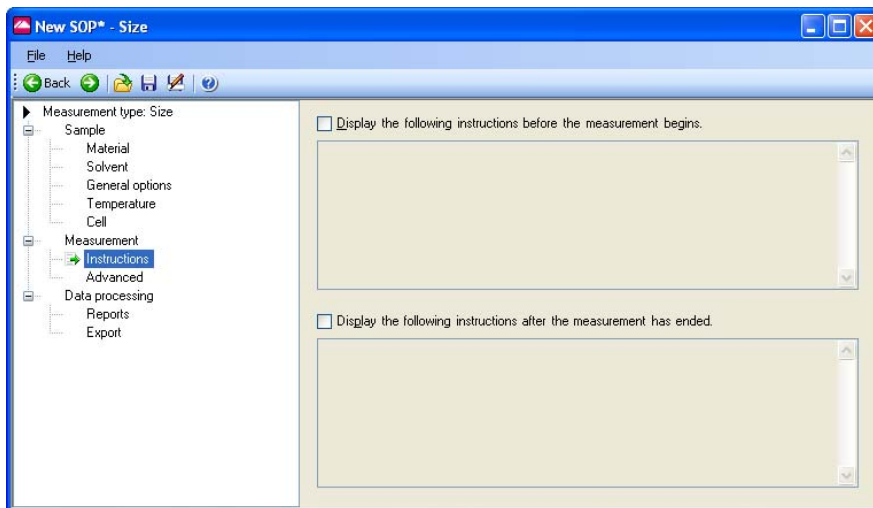

This dialogue will not appear when doing a manual measurement.

Display the following instructions...before...

This area is useful to give details that will allow measurements to be made correctly and consistently; e.g:

- The SOP creator may give comments that inform that this SOP should only be used for certain batches of sample.
- Detail can be provided to describe how to prepare the sample.

Display the following instructions...after...

With this check box selected post-measurement instructions can be displayed on any administration or sample handling details that could not be detailed in the SOP dialogues.

Measurement - Advanced

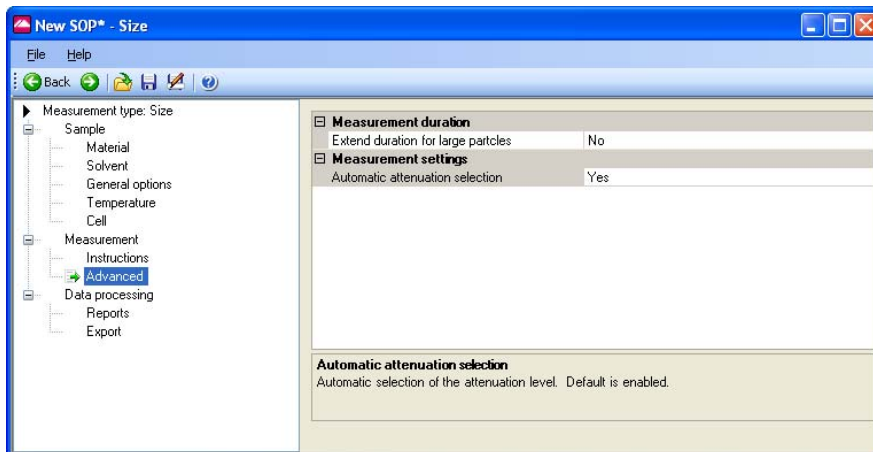

The **Advanced** dialogue contains functions to alter the cell and attenuator position settings. For normal operations both will be at the **default** setting.

Data Processing

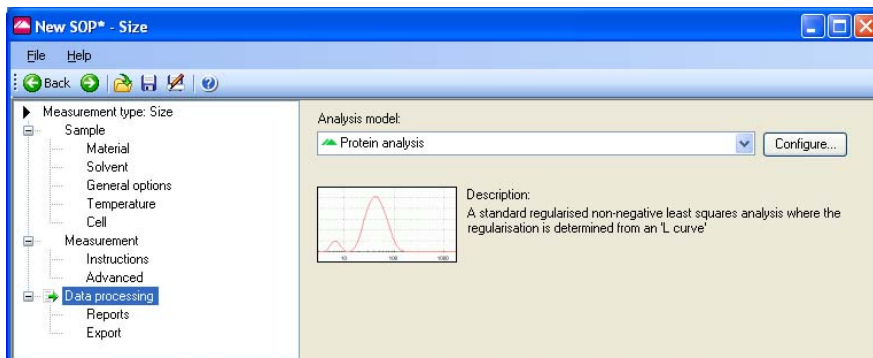

If characteristics are already known about the sample being measured, this dialogue will allow an appropriate analysis model to be applied and so optimise the measurement calculation. Size ranges and measurement thresholds can be applied to the analysis to filter spurious peaks out prior to the analysis being performed.

Three **Analysis Models** are available - **Protein Analysis**, **General Purpose** and **Multiple Narrow Modes**, plus a custom analysis model can be applied (**Load analysis settings...**).

Each **Analysis Model** can be altered using the **Configure** button.

Please see the **Help** file for more information.

Analysis Models

■ Protein Analysis

The default setting, select this model when undertaking a protein analysis.

■ General Purpose

Select this model if the characteristics of the sample to be measured are unknown.

■ Multiple Narrow Modes

If it is known that the sample to be measured will give a distribution of one or more narrow peaks (i.e. a multi-modal distribution of latices) then select this model.

■ Load Analysis settings...

This enables a previously saved analysis model to be loaded and used for the data processing. These are saved as **.dass** files. (The last **s** indicates the analysis setting has been created for a **Size** or **Molecular weight** measurement).

Configure button

The **Configure** button dialogue enables various attributes of the analysis model to be altered. These include the **Name**, the measured Size **Display range**, the **Analysis mode** and the measurement **thresholds**. The altered analysis model can then be saved. Analysis models are saved as **.dass** files.

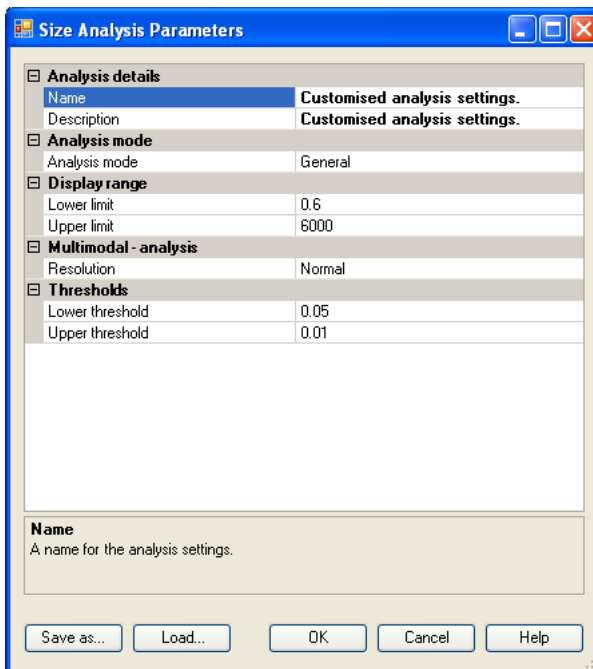

If it is known that all particles within the sample will fall within a certain size range, then the size **Display range** can be set to ignore data or artifacts at each end of the distribution. The transformations to volume and number will then ignore the data outside the set limits. Similarly lower and upper **thresholds** can be applied to eliminate undesired populations that are below a defined percentage of the particle population.

Change the **Name** and **Description** fields in the **Analysis details** to reflect the new Analysis settings.

To **keep** the new analysis model, press the **Save as...** button, then press **OK** to exit the dialogue and use the analysis model; the new analysis model name will now be displayed in the **Analysis model** entry box on the **Data Processing** dialogue.

**Note**

If no name has been given, the analysis model will be displayed as **Customised analysis settings** in the **Analysis model** entry box.

Previously saved analysis models can be used, viewed and altered by pressing the **Load** button. Pressing **OK** will exit the dialogue and add the model to the **Analysis model** entry box.

**Note**

The Analysis settings files can be saved and loaded independently of the SOP. Only the analysis settings in the file will be used in the SOP, the file itself is **not** attached. This means that any subsequent changes to the Analysis file will **not** change the SOP. The analysis settings file will have to be reloaded into the SOP for the changes to take place.

Data Processing - Reports

The **Reports** dialogue enables various reports to be selected and then printed automatically once the measurement has finished.

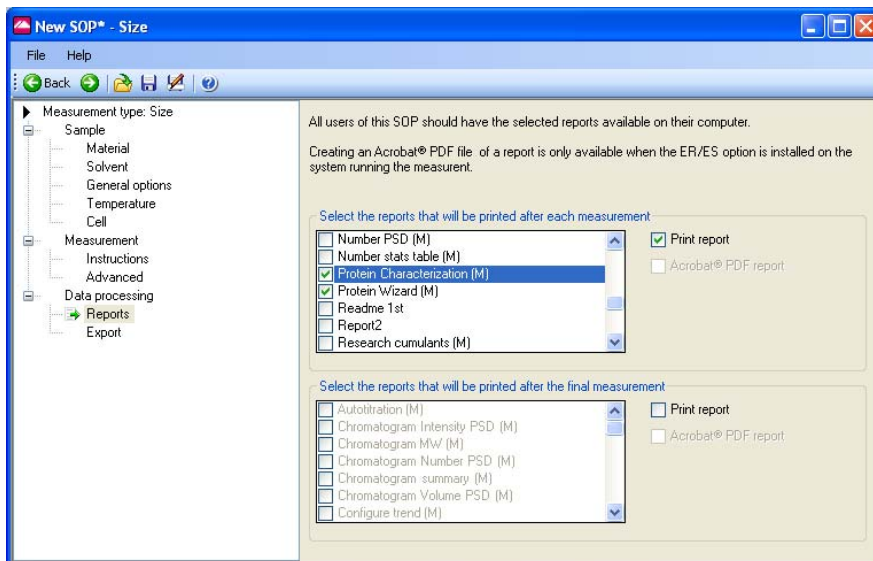

Two selection boxes are available. One to enable a report to be printed after **each** measurement is completed and the other to print out a report after **all** measurements have been completed. For each, select the **Print report** check box and then the reports required. Any reports created using **Report Designer** will automatically be added to this list.

If the 21 CFR part 11 feature key is installed reports can be converted to Acrobat® PDF format and saved.

Data Processing - Export

The **Export** dialogue enables the measurement results to be exported to third party software packages such as Excel or Wordpad.

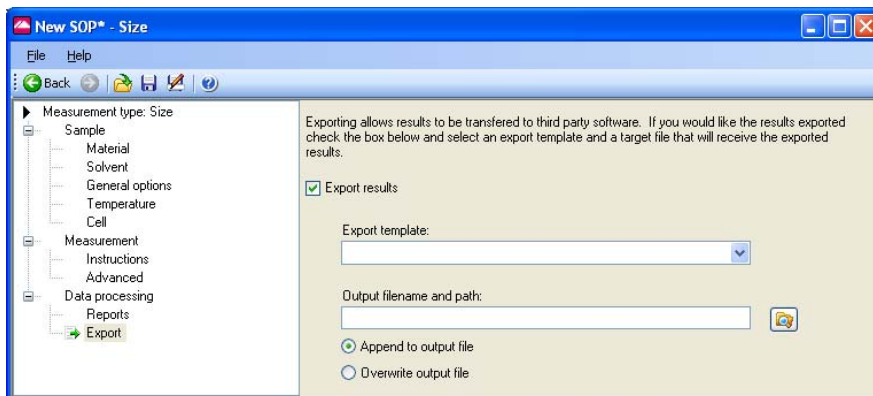

With the **Export results** check box selected measurement parameters can be defined and exported on completion of the measurement. Select the required **Export template** from the list; this will display the export dialogues described in **Chapter 10**. Refer to this chapter for full details on creating the export templates.

The parameters will be exported as a text file to the specified **output filename...** and saved.

Append to file will add the exported results to the existing file while **Overwrite file** will replace any previous measurement results so only the last measurement will be available.

Molecular weight SOPs

The majority of the **Sample** and **Measurement** dialogues described below are **unique** to **Molecular weight** measurements, however when indicated please refer to the description in the **Size SOP** section. The **Molecular Weight SOP editor** menu is shown right:

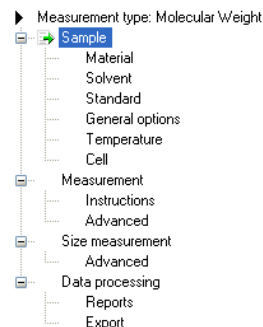

The dialogues are described in turn below.

Sample

Please refer to the **Sample** description in the **Size SOP** section.

Sample - Material

Please refer to the **Sample - Material** description in the **Size SOP** section for details.

Sample - Solvent

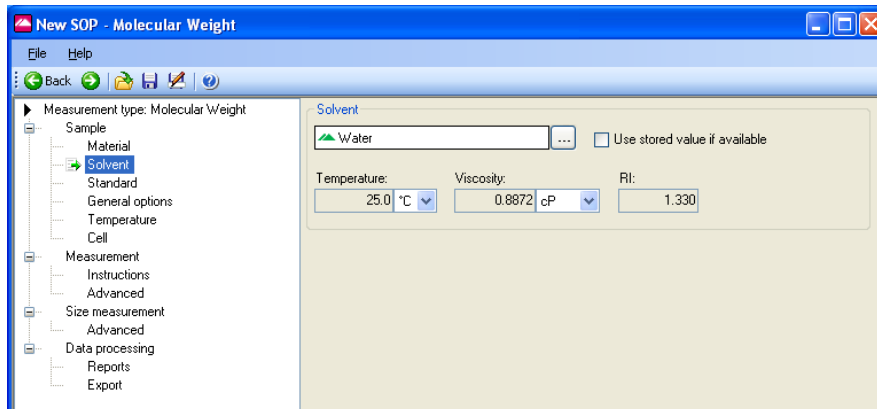

The Zetasizer software requires certain information about the physical properties of the dispersant that is used in the sample that is to be measured. By selecting the **Sample - Solvent** dialogue and pressing the button, the **Solvents properties manager** will appear where these properties can be defined. Click **Use stored value if available** to force the system to use the solvent values from memory (if present) rather than re-measuring them - this can slightly seed up the measurement.

Solvents Manager

Selecting this dialogue enables solvents to be added, modified and deleted.

To define a new Solvent, press the **Add...** button and choose from defining either a **Simple dispersant or solvent** or a **Complex solvent**.

Please refer to the **Sample - Dispersant** description in the **Size SOP** section for details.

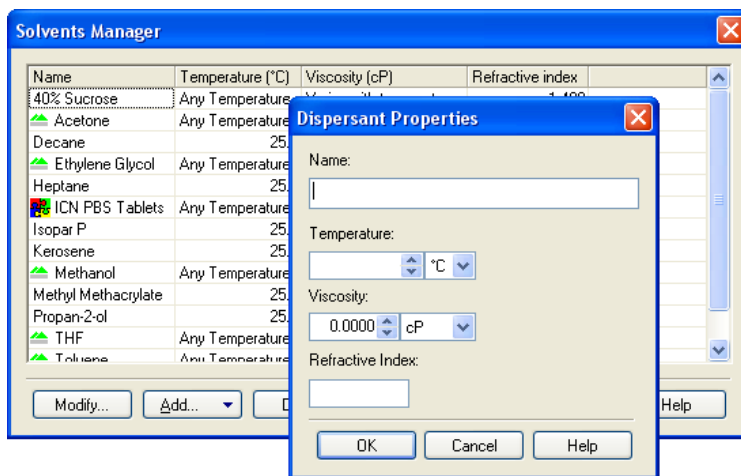

Sample - Standard

The Zetasizer software requires certain information about the “Standard” used for laser intensity calibration. By selecting the **Sample - Standard** dialogue and pressing the button, the **Standards properties manager** will appear where these properties can be defined.

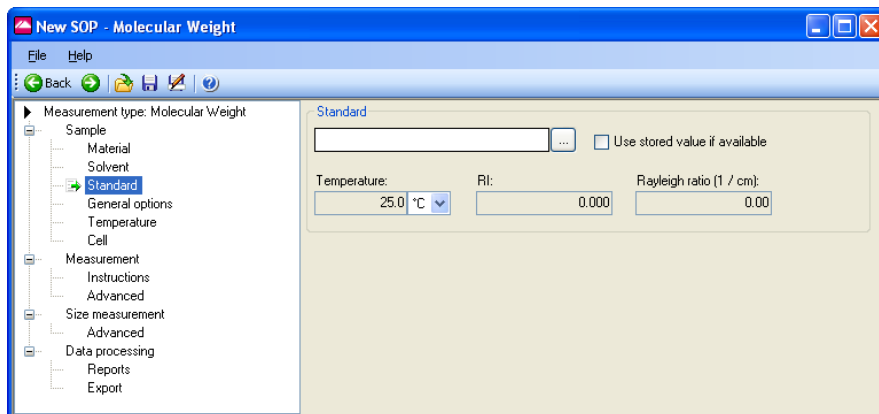

Standards Manager

Input and define the scattering “standard” properties of the liquid to be used in the measurement: **Temperature**, **Refractive index** and **Rayleigh ratio**. This will nearly always be Toluene.

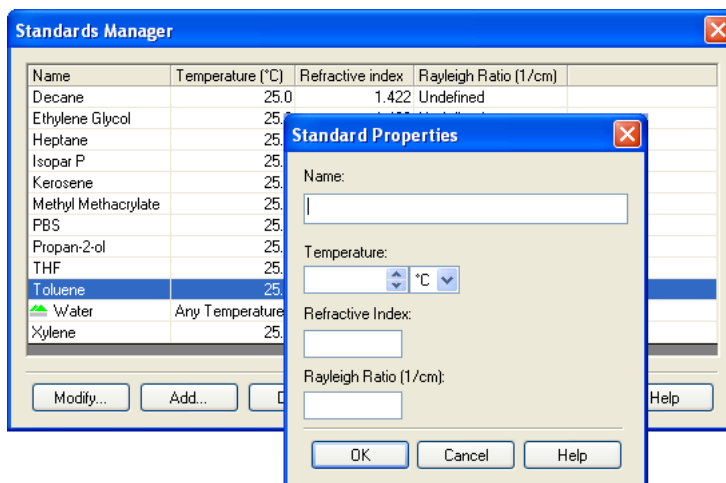

The standard properties can be added, modified and deleted in the same way as detailed for the **Solvent Manager** above.

Sample - General Options

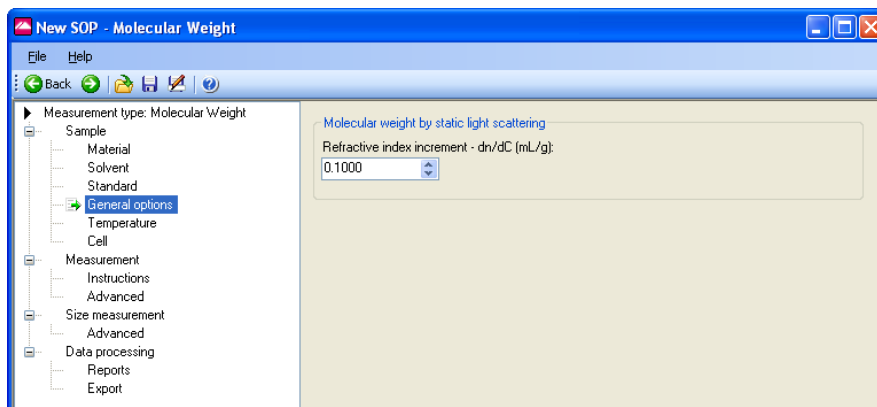

Molecular weight by Static Light Scattering

Input here the differential refractive index increment (dn/dc) of the solvent. This is the change in refractive index as a function of the change in concentration. For many sample/solvent combinations this may be available in literature; while for

novel combinations the dn/dc can be measured by use of a sensitive differential refractometer.

**Note**

This will require a refractometer capable of measuring to an accuracy of six decimal places.

Sample - Temperature

Please refer to the **Sample - Temperature** description in the **Size SOP** section.

Sample - Cell

Please refer to the **Sample - Temperature** description in the **Size SOP** section. Cells are listed that are appropriate to molecular weight measurements.

Measurement

The **Measurement** dialogue allows the duration of the measurement to be set, and multiple measurements of the same sample to be made.

Also refer to the **Measurement-Advanced** dialogue below.

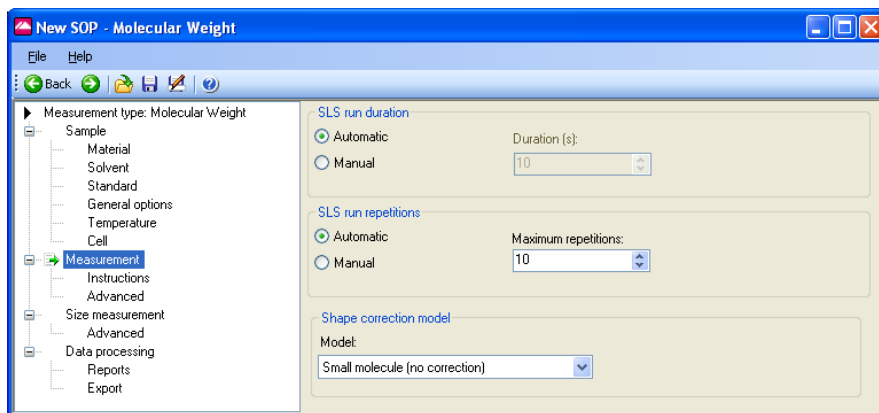

SLS run duration

The measurement duration setting affects the accuracy and repeatability of the results.

With **Automatic** selected, the software will automatically determine the measurement duration.

With **Manual** selected the measurement will use the user defined settings.

Shape correction model

This option allows selection of the shape correction model used for the measurement. With knowledge of the sample structure it is possible to improve the result of the measurement by adding the value that most closely corresponds to the probable sample shape; i.e. sphere, coil, cylinder or no shape correction.

Measurement - Instructions

Please refer to the **Measurement - Instructions** description in the **Size SOP** section.

Measurement - Advanced

The purpose of this dialogue is to allow users the option to adjust the (**variation**) **factors** that are used in determining the length of an '**automatic duration**' measurement; as detailed in the **Measurement** dialogue above.

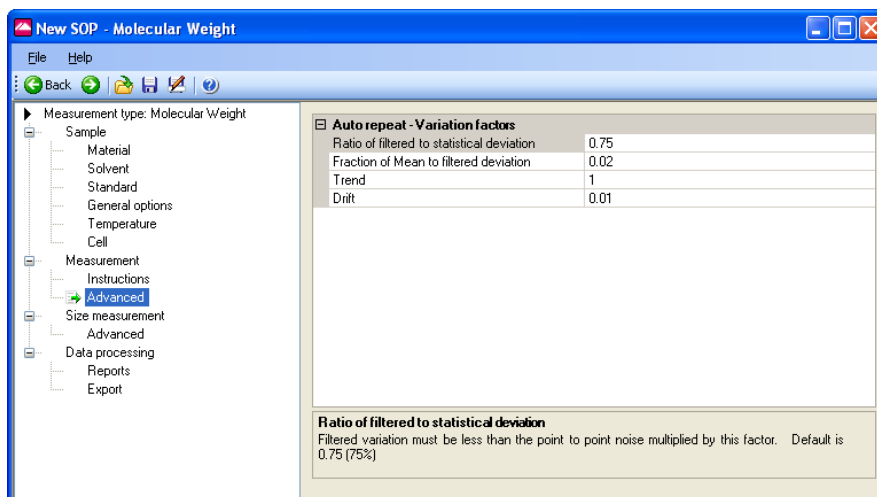

The measurement process takes a sequence of count rate measurements, one every 125 milliseconds, for the run length specified.

This automatic default will normally be 10 seconds though this may increase for lower scattering samples to help increase the accuracy. The **Run duration** range should typically be within the range 10 to 50 seconds.

Performing only one run may not always be sufficient to achieve a good measurement of the intensity. This is because the sample scattering will normally show some systematic variations, as well as an expected random variation about a mean value.

These systematic variations can occur for a few reasons; possibly thermal drifting of the sample, poorly mixed sample, or instrument and laser stabilisation after initial switch on. (Wait 30 minutes after switch on for the laser to stabilise).

If any variations are detected that are greater than the set values, then the measurement will be repeated until a result below the thresholds is achieved.

Adjusting the **Variation factors** will enable a percentage of these systematic variations to be ignored during the measurement process, therefore allowing a quicker measurement to be performed.

The **default** variation factors are:

- **Ratio of systematic to statistical deviation**

The systematic deviation should be $< 0.75 \times$ the statistical noise

- **Fraction of Mean to systematic deviation**

The systematic deviation should be $< 0.02 \times$ the mean

- **Trend**

The trend $<$ statistical deviation ($\times 1$) - the default factor

- **Drift**

The trend should be $< 0.01 \times$ the mean

During a measurement the size of these components is compared to the random noise and the mean value. The run will be accepted if they are sufficiently small.

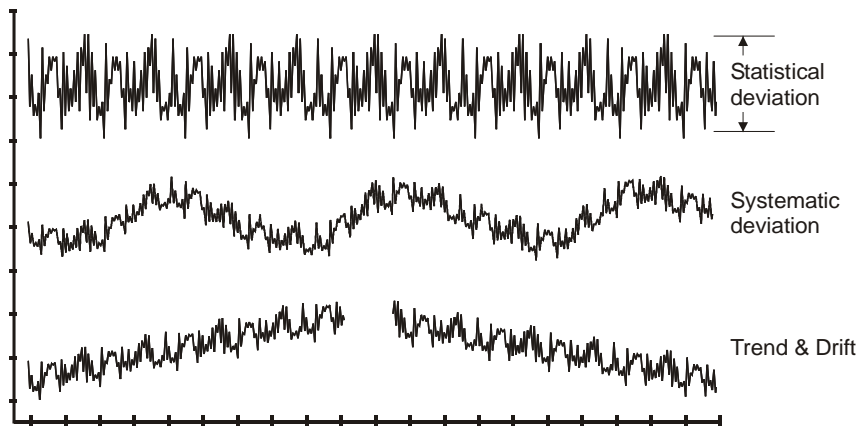

ill 7909

Size Measurement

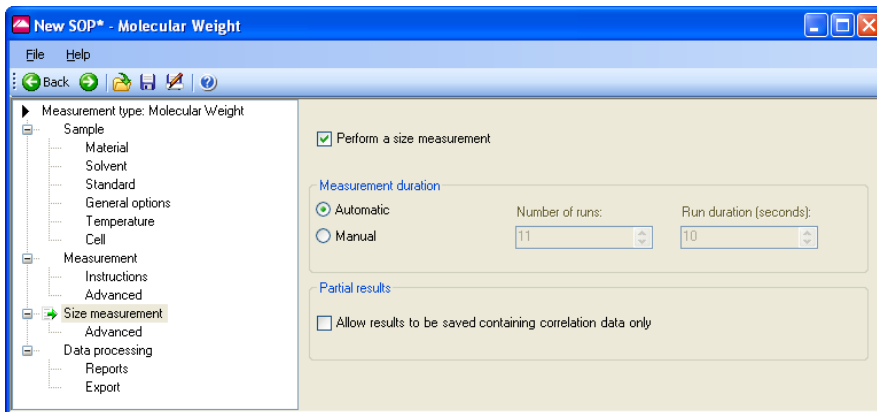

With the **Perform a size measurement** check box selected a size measurement will be performed simultaneously with Molecular weight.

Measurement Duration

The **Measurement Duration** setting can affect the accuracy and repeatability of the size results.

Please refer to the **Measurement** description in the **Size SOP** sections, for details of the **Measurement duration** settings.

Partial Results

If it is likely that a measurement will not produce a correlation function that can be analysed, then the data collected can still be saved by selecting the **Allow results to be saved containing correlation data only** check box within the **Partial results** area.

Please refer to the **Measurement** description in the **Size SOP** section, for details of the **Partial Results** settings.

Size Measurement - Advanced

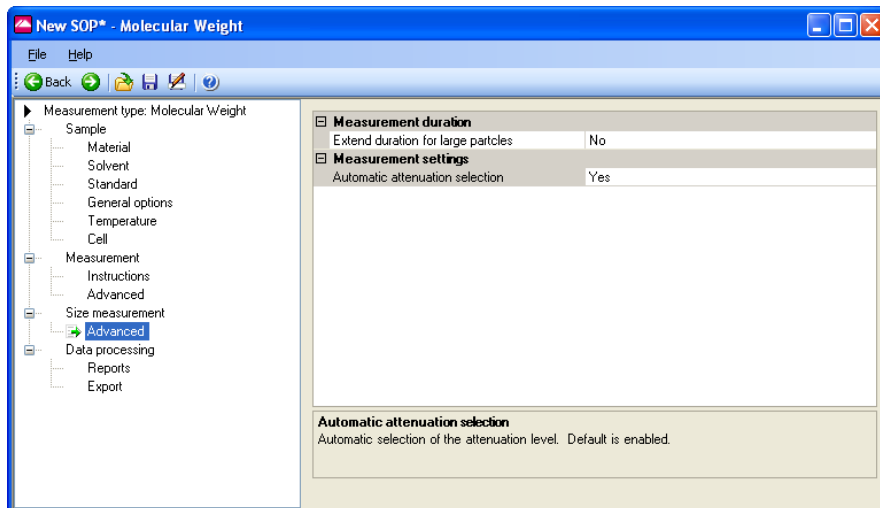

Measurement settings

Please refer to the **Measurements - Advanced** description in the **Size SOP** section for a description of the **Measurement Position** and **attenuator** functions.

Data Processing

If characteristics are already known about the sample being measured, this dialogue will allow an appropriate analysis model to be applied and so optimise the measurement calculation.

Please refer to the **Data Processing** description in the **Size SOP** section.

Data Processing - Reports

Please refer to the **Data Processing - Reports** description in the **Size SOP** section.

Data Processing - Export

Please refer to the **Data Processing - Export** description in the **Size SOP** section.

Flow-mode SOPs

The **Flow SOP editor** menu is:

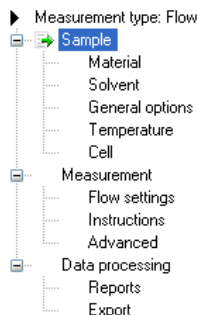

The **Flow**-mode SOP enables measurements to be performed on a flowing sample stream. The Scattered light intensity and Hydrodynamic diameter can be plotted as a trend, and, with the addition of optional external input dialogues, information from external measuring sources, such as a refractive index detector, can be monitored and displayed.

In general, flow-mode SOPs are the same as the standard Size SOPs, the only differences being the inclusion of **External Input** SOP dialogues. These are described below. The **Delay volume** is the volume of liquid contained in the cells and connecting tubing between the external detector and the Zetasizer μV . This parameter ensures that data recorded by the Zetasizer can be overplotted from the same elution point.

This value will be obtained from the external detecting device (i.e. chromatographic column) that is used in the flow-mode measurement.

The **default** settings, for name, delay volume, offset and gain, can be adjusted using the **Tools-Options-External Inputs** dialogue.

Measurement

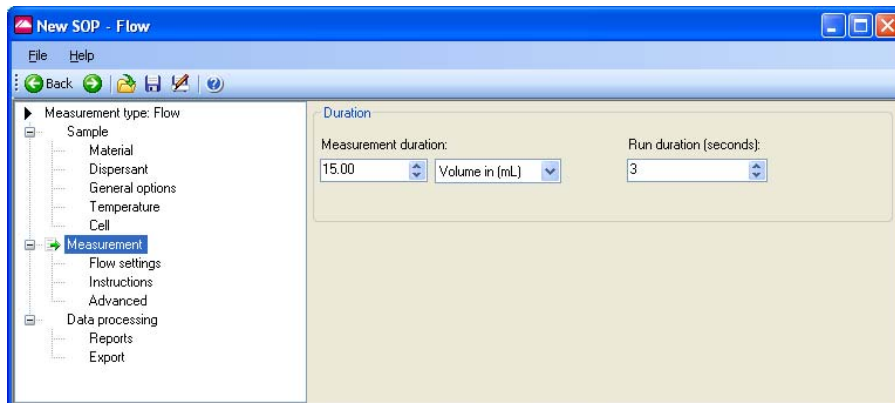

Measurement Duration

The measurement duration setting may affect the accuracy and repeatability of the results. In **Measurement duration**, input the total measurement time or volume amount required, and adjust the units to suit: **Time** or **Volume**.

The **Run duration** value determines the length of each individual measurement within the experiment.

Flow settings

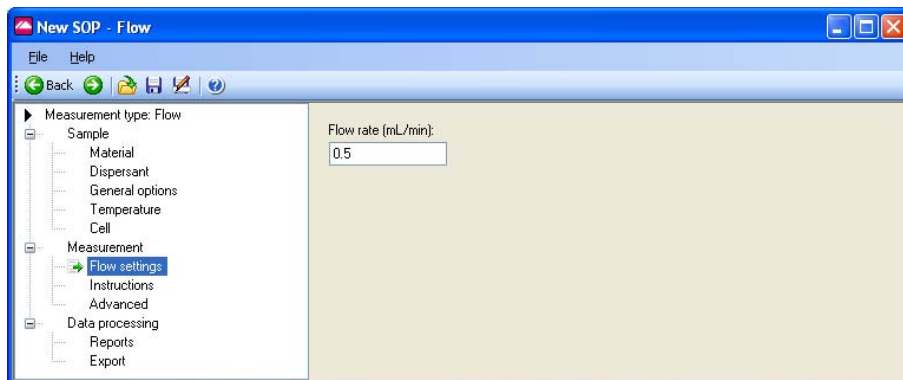

Flow rate

Input the flow rate of the sample through the instrument and connecting tubing. This value is taken from the external detecting device (i.e. chromatographic column) that is used in the flow-mode measurement.

For all other SOP dialogues, refer to the Size SOP section.

Trend SOPs

The **Trend SOP Editor** menu is:

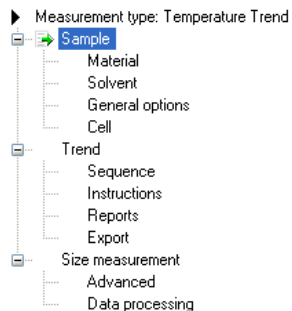

The **Trend** SOP allows size and Zeta measurements to be performed and plotted as a function of temperature.

Trend SOPs are similar to the standard size and Zeta SOPs, the differences being the inclusion of a trend and altered measurement dialogues.

Melting Point SOPs

Melting point measurements can be performed by selecting a check box on the **Trend - Sequence** dialogue. This will enable the protein **denaturation** point to be determined. This measurement will be performed as a function of temperature.

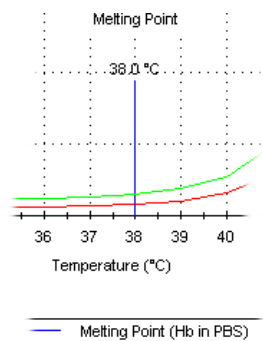

Trend - Sequence

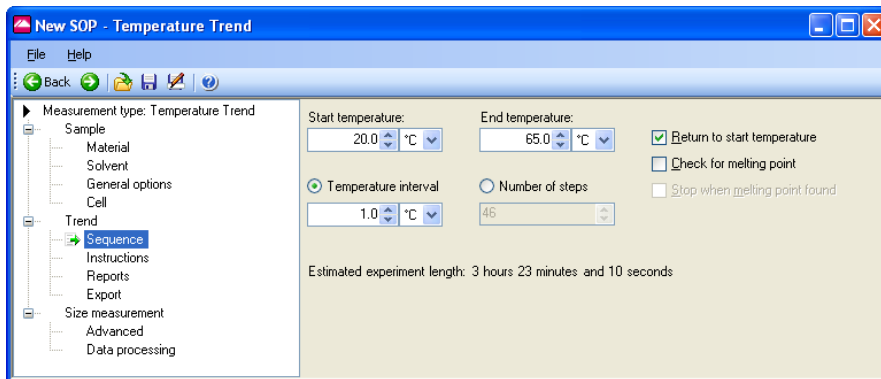

The **Trend - Sequence** dialogue enables the selection of the temperature trend parameters, i.e. start and end temperatures, and intervals between measurement steps.

Start Temperature

Input the temperature that the **first** measurement is to be made at. The instrument will initially cool, or heat, to this temperature before starting the measurement.

End Temperature

Input the final required temperature. Once this temperature is reached the measurement will stop.

Return to Start temperature

If this check box is selected, once the melting point has been determined the measurement will return to the original starting temperature defined above.

Temperature Interval / Number of steps

The measurement can be configured to change either in specific measurement intervals (e.g. every 5°C), or in a specific number of steps (e.g. 10 steps). Select the button to identify which is required.

Melting point measurements only

Check for Melting point

If the protein **denaturation** point is to be determined as part of the measurement, select the melting point check box.

Stop when melting point found

If this check box is selected the measurement will stop once the melting point has been determined.

Size Measurement

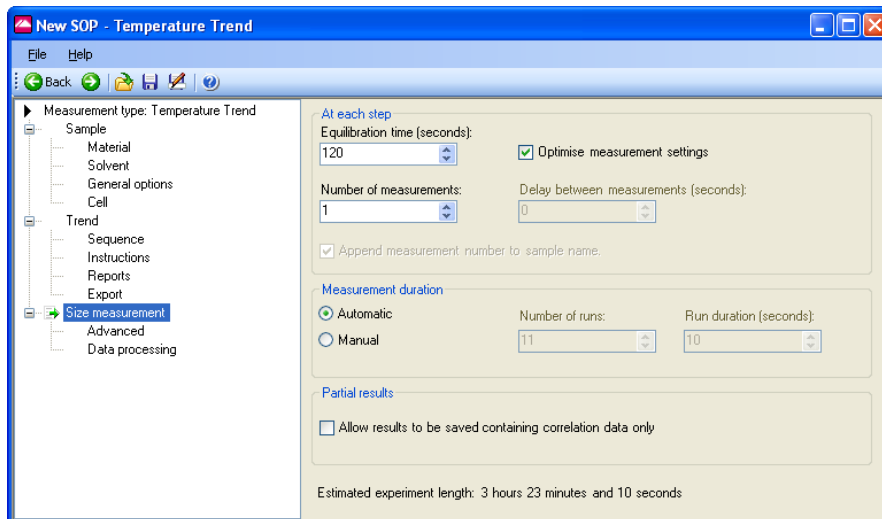

The trend and melting point measurement dialogues are generally the same as those used with either a size or Zeta measurement SOP. The additional features are:

- **At Each step** gives the option to control the **Equilibration time** and **Number of measurements** performed.
- **Optimise Measurement settings** enables the cell position to be checked and verified before each individual measurement is performed. This option is **not** available with the melting point dialogue.

Please refer to the **Measurement** description in the size and Zeta SOP sections, for details of the **Measurement duration** and **Advanced** settings.



Extracting an SOP

The SOP (or manual settings) used when performing a measurement can be viewed by right-clicking on the measurement record and selecting **Extract SOP**. This will display the SOP dialogues.

If required the SOP can be modified and saved under a new name.

Modifying an SOP

To modify an SOP, select **File-Open-SOP**. The SOP dialogues will be displayed, allowing any settings to be changed.

Alter the settings within the dialogues, and then save (select **File-Save**  or **File-Save as...**  as appropriate).

If measuring similar samples, it is often easier to modify an existing SOP and then save it under a different name.

Distributing an SOP

SOPs are designed to allow the measurement of the same type of sample in a consistent way - if monitoring batches of sample in a quality control environment, the results will be meaningless if different measurement parameters have been chosen for each batch.

Consider an application where a manufacturer is producing the same type of sample in different factories. It will be important that the measurement protocol is consistent between factories.

An SOP can be created and copied into the SOP directory on another Zetasizer μV instrument so that measurements are consistent. Simply copy the **.sop** file to all computers running a Zetasizer μV system.

If the SOP has a non-standard dispersant defined then this will not exist on the target computer. When the SOP is run on the target computer, the software will detect this and give the following choices:

- Add the dispersant to the dispersant database.
- If the dispersant already exists, the software will ask if the existing dispersant parameters should be overwritten or saved under a new name. It should be noted that if the dispersant parameters are overwritten, the new parameters will then be used for all SOPs that use that dispersant.

Advanced features

Introduction

This chapter contains the following **advanced** features and capabilities of the Zetasizer μV :

- Solvent builder
- SOP player
- Averaging results
- Editing the result
- Exporting the results
- Flow-mode capability
- Options dialogue
- Expert advice

Solvent Builder

The Solvent builder is a database of components that can be added in different quantities for estimating the properties of solutions. The database is used for the calculation of **Complex solvents**; generally necessary when performing measurements involving proteins.

The dialogue below will appear when **Complex solvent** is selected when adding a dispersant or solvent in the **Sample SOP** dialogues.

Component	Concentration	Viscosity Increment	RI Increment
Water	--	0.88718	1.33000
Acetone	0.1200	0.02893	0.00047
2 Propanol	0.0600	0.03157	0.00023

The Solvent builder is used for:

- **Size or Molecular weight SOPs** - calculating the viscosity and refractive index for non-standard solvents.

The calculations operate using the assumption that changes in the base solvent properties will be additive.

- For example, if the addition of 10% glycerol increases the refractive index of water by 0.0118 and the addition of 0.5 M calcium chloride increases the refractive index of water by 0.0128, then the addition of both will increase the value by 0.0118 + 0.0128, in total 0.0246.



Note

The Additive effect on both viscosity and refractive index is determined using 3rd order polynomial fits of data compiled in the “65th Edition of the CRC Handbook for Chemistry & Physics”.

Building a Complex solvent

To generate a Complex solvent, a few sample parameters have to be entered into the builder dialogue.

The **Summary** area details the chosen name for the new solvent, plus its calculated viscosity and refractive index. Do the following:

- Input the **Name** of the new solvent.
- Select the **Primary solvent** used for the new solvent (i.e. water).
- Select an **Additive** from the list and enter its **Concentration**, either directly or by using the **Molarity Calculator** button and associated dialogue (below).

Input the **weight** (%) and the **Molecular Weight** (g/mol) of the additive.

The **Molarity** (mol/L) will be automatically calculated.

Press the **OK** button to enter the value into the **Concentration** column of the solvent table, otherwise press **Cancel** to exit the dialogue without updating.

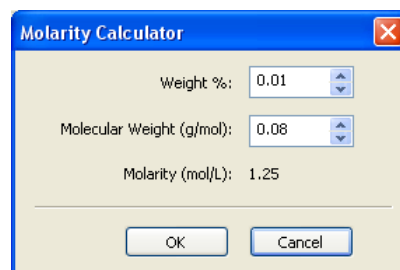

- Press the **Add** button. The refractive index and viscosity increments will be added to the table, with the total solvent viscosity and refractive index, or dielectric constant, calculated and displayed in the **Summary** area.
- If any additive needs to be deleted from the solvent, highlight it and press the **Remove** button to delete the additive from the table.
- Press **OK** and the new solvent will be added to the Dispersants/Solvents manager.

To **modify** a dispersant, once created, select the dispersant from the list and press the **Modify...** button (or double-click the dispersant in the list). The **Complex Solvent** dialogue will appear, allowing the parameters to be changed. The builder will only appear if the solvent was originally created using the builder and not the standard **Dispersant** properties dialogue

Complex solvents have this icon  displayed before the solvent or dispersant name in the **Solvents** or **Dispersants Manager** dialogues.

A dispersant, or solvent, can be **deleted** by selecting the dispersant from the list and pressing the **Delete...** button.

Note that it is not possible to modify or delete any dispersants or solvents that were specified by Malvern.

SOP Player

The SOP player is a stand alone dialogue that enables a sequence of **actions** - SOPs, measurements, pauses or macros - to be constructed and then played. This sequence is called a **playlist**.

This is useful for performing different measurement types consecutively without any user interaction; a **playlist** can be created, the **Start** button pressed, and the measurement allowed to be continue, performing measurements in sequence with appropriate pauses, or macros.

An example application for using the SOP player is a **Temperature trend with titration measurement**:

- i.e. increase the temperature of a sample - measure,
- add some titrant - measure,
- decrease the temperature - measure,
- and repeat.



Note

A playlist **must** be saved before playing





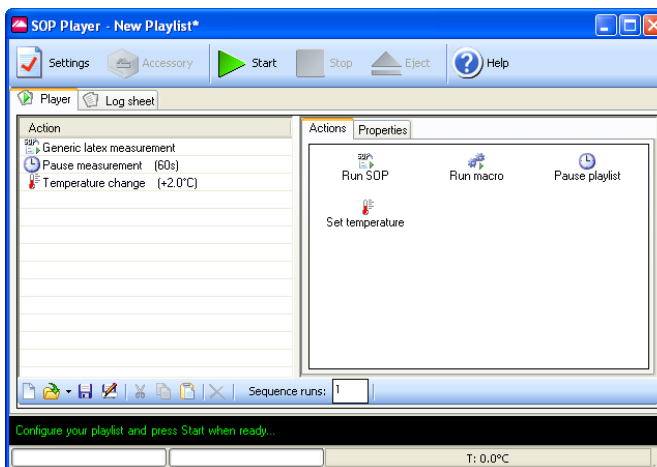









SOP player dialogue

To open the player select **Measure-SOP Player**. The dialogue below will appear.

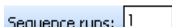

Note, that when first opened, the table on the left will normally be blank. The actions shown are only for reference.

The SOP player controls are:

Button	Description
	Select this tab to add new items (or actions) to a playlist. Choices are SOP, Macro, Temperature and Pause. These are described below.
	Input the properties for the selected action.
	Creates a new 'blank' playlist page. This will overwrite any playlist currently displayed. A prompt to save the current playlist will be shown.
	Loads a previously stored playlist. By default playlists are stored in the SOP directory under a .sopl filename.
	Saves a newly created or modified playlist. A playlist must be saved before being played.
	Saves a modified playlist under a different file name.
	Cuts the selected action(s) out of the playlist. It can then be pasted to the end of the playlist.
	Copies the selected action(s) in the playlist. It can then be pasted to the end of the playlist.
	Pastes the copied or cut action(s) to the end of the playlist
	Use this button to remove actions from a playlist. Either the selected item can be removed, or the complete playlist cleared.
	Enter how many times the playlist is required to be run.
	Opens the documentation window. Sample name and instructions can be inputted. Refer to the Sample description in the Size SOP section.
	Plays (starts) the currently viewed playlist measurement. The measurement display will then open. An extra tab will be present showing the measurement playlist.
	Stops the current playlist measurement.

Construct the playlist by selecting and configuring the **Actions** in the left pane; These are described in the following sections. The list can be arranged in order as required by dragging and dropping an action at the desired point.

For each action, enter the action properties as required. An instruction for the parameter is displayed at the bottom of the Properties tab.

Properties	
[-] Pause	
Type of pause	Wait for a specified duration
Description	Pause measurement
Duration (s)	60
Description Enter a description for the pause, e.g. why the playlist is being paused.	

When the playlist is played using  button, the **Measurement display** will appear; the actions being performed can be viewed by selecting the **Log sheet** tab, whilst the playlist can be viewed by selecting the **Player** tab. All other functions of the Measurement display are as previously described in the manual.

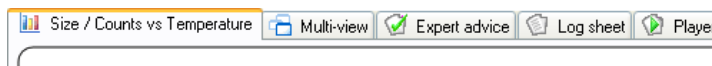

Run SOP..

To add an SOP, select the **Run-SOP** icon; The dialogue below will appear.

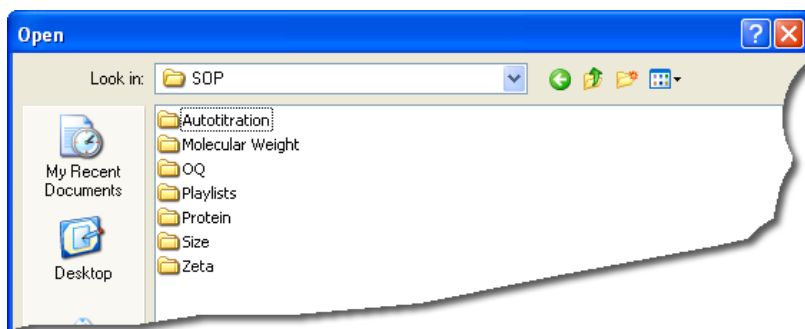

Select the required SOP from the list and press **Open**. The SOP will be added into the playlist. The SOP will be identified in the playlist by its SOP filename.

Actions	
[-] Sample Details	
Sample name	Sample X
Notes	example notes here
[-] SOP	
SOP path	C:\Documents and Settings\scoombe\M

Selecting the SOP in the Playlist will display both the SOP properties and the sample details. Select each parameter to edit as required. The SOP used can be changed by selecting ; this will open the dialogue above.

If the SOP is to be altered, this must be done using the **SOP Editor**.



Note

It is important to ensure that the measurement cells selected in an **action** are compatible for all other actions in the playlist. This includes all SOPs and Macros selected.

Run Macro...

To add a Macro program, select the **Run Macro** icon. The dialogue below is displayed.

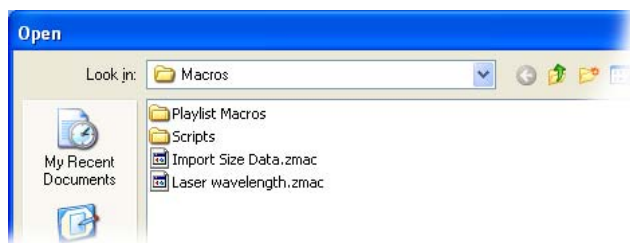

Select the required Macro from the list and click **Open**. The Macro file path will be added into the entry box. The Macro will be identified in the playlist by the its filename.

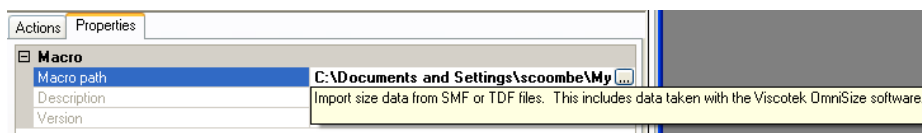

Complete the relevant **Parameters** as required. Follow any instructions indicated in the **Description** field.

The **Parameters** section allows additional options to be passed to the macro. The description or details of the selected Macro will explain what should be entered here. Generally this will be the type of function or task the Macro will perform. The values entered will be shown alongside Macro filename in the playlist.

The Macro used can be changed by selecting ; this will open the dialogue above.

**Note**

The Macros available will be supplied by Malvern.

Pause Playlist

To add a pause (or time-delay) between each playlist action, select the **Pause playlist** icon. This will add a **pause** action into the playlist, with the properties displayed alongside.

Alter the properties as required. Enter the pause **Description**, this will identify the pause in the playlist, and enter the pause **Duration**. The details entered will be shown alongside the Pause action in the playlist.

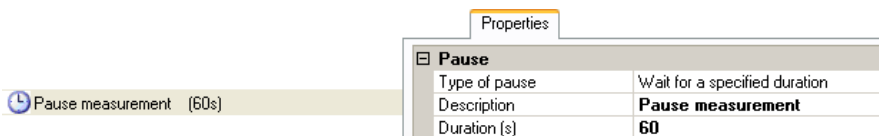

The screenshot shows a playlist item 'Pause measurement (60s)' with a clock icon. To its right is a 'Properties' dialog box for the 'Pause' action. The dialog box contains the following table:

Pause	
Type of pause	Wait for a specified duration
Description	Pause measurement
Duration (s)	60

A pause may be required to allow for thermal equilibration before proceeding.

Set temperature

To add a temperature change or setting between each playlist action, select the **Set temperature** icon. This will add a **Temperature** action into the playlist, with the properties displayed alongside.

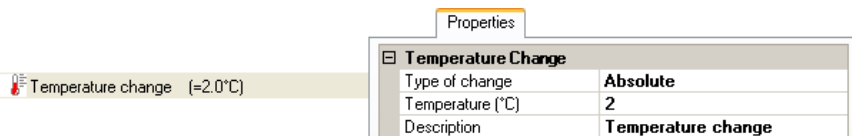

The screenshot shows a playlist item 'Temperature change (=2.0°C)' with a thermometer icon. To its right is a 'Properties' dialog box for the 'Temperature Change' action. The dialog box contains the following table:

Temperature Change	
Type of change	Absolute
Temperature (°C)	2
Description	Temperature change

Alter the properties as required. Enter the temperature **Description**, this will identify the temperature change in the playlist. Also enter the **Type of temperature change** and the **temperature** value to be achieved; note that this is dependent on the **Type of temperature change** option selected:

- **Type of change : Relative**

Enter the temperature “change” required from the current temperature.

If the current temperature is 25°C and the new temperature required is 23°C. then enter -2 as the value; the instrument will cool until that 23°C is achieved.

- **Type of change : absolute**

The temperature will go to the temperature requested.

If 10°C is entered, the instrument will cool, or heat, until that temperature is achieved. The temperature range available is that of the instrument: 2°C to 90°C.

The details entered will be shown alongside the temperature action in the playlist.

**Note**

Any temperature requested in the **Set temperature** action will override the temperature setting requested in any previous SOP action within the playlist. It is recommended to amend the **Set temperature** value **back** to ambient at the end of the playlist; otherwise, when the playlist finishes, the temperature will stay at the last value requested.

Result averaging

What is the average result of a selection of records?

Highlight the required records and either select **Edit>Create Average Result** or **right-click** on the records and select **Create Average Result** from the displayed menu. An averaged result record will then be generated and added to the end of the measurement file. The averaged result will display **Average** in the result's Origin column.

Before the averaged result is created a dialogue will appear so comments can be added and the sample name changed, if required.

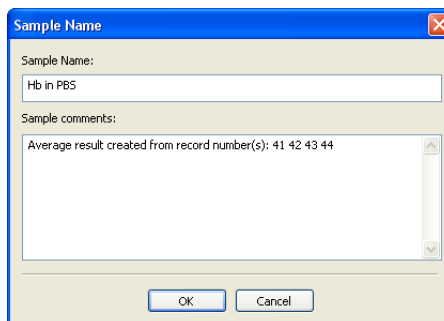
**Note**

When averaging, the result source must be the same. A previously averaged record cannot be averaged again.

Editing the result

It is possible to re-analyse a measurement record using different measurement parameters. The re-analysed record will be added to end of the current file. Comments on the reasons for editing can be added and viewed in the report views.

This option allows measurements to be reanalysed without the need for the instrument to be connected.

Select the menu item **Edit-Edit result** or right-click on a measurement record and select **Edit Result**; The **Edit Result** dialogues will appear - these will be similar dialogues to those within the **SOP Editor**. As with the **SOP Editor**, the dialogues shown will differ, depending upon the measurement type selected. The example below shows the **Edit result dialogues** available when a **Size measurement** is selected.

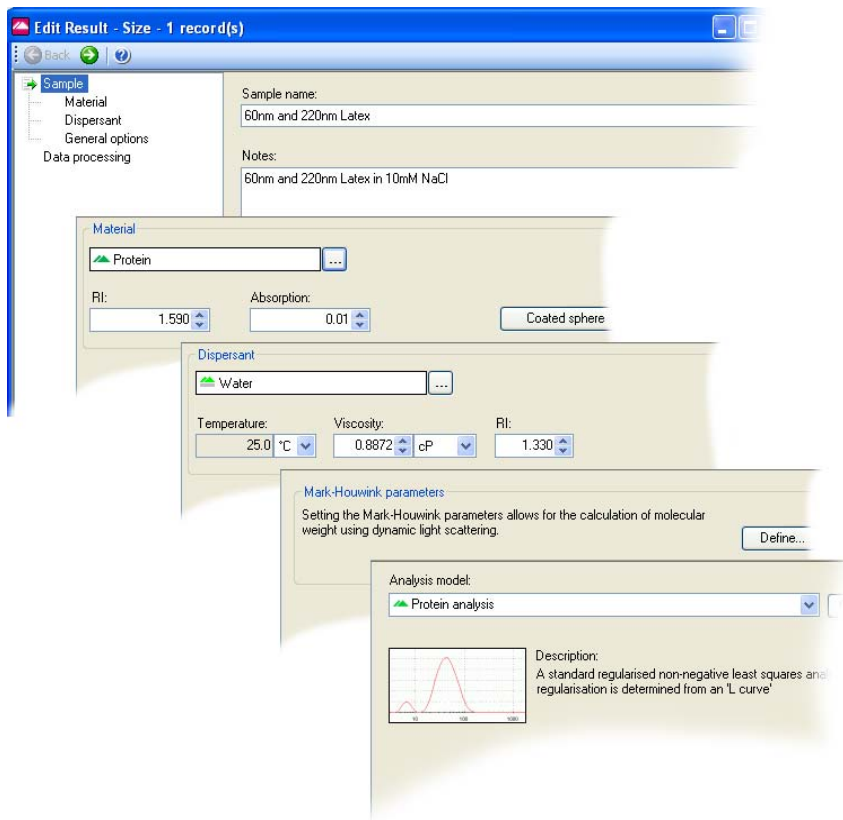

**Note**

Each edit result dialogue will be slightly different depending upon the measurement type originally performed. The picture above shows the size view.

Multiple results can be edited by selecting the records required before selecting the edit result dialogue.

► To Edit a result:

- **Right-click** on the required measurement record(s) and select **Edit Result**.
- Select the appropriate dialogues and alter the required parameters, then press **OK**. It is advisable to add the modified parameter to the records list so the altered records can be instantly identified.
- The result will instantly be reanalysed and the result added to the **Record view**.

Editing a Flow-mode result

When a flow-mode result is selected for editing, a flow-mode plot dialogue will be displayed. This will allow the flow-mode result to be edited and reanalysed, and the flow-mode plot to be viewed and the peaks inspected.

Refer to the **Editing and inspecting the Flow-mode result** in the **Flow-mode** section later in this chapter.

21 CFR Part 11

If the 21 CFR part 11 feature is installed, a **Reason for change** dialogue will appear so comments can be entered detailing what changes have been made.

The reasons for change, can be displayed in the **Records view** tab by selecting the **Measurement-Audit information-Reason** in the **Workspace settings** dialogue (Select **Configure-Workspaces-“..workspace choice..”** and then the **Record view** parameters tab).

Exporting results

The Zetasizer software allows any of the parameters from one or more records, as well as graph and table data to be exported to another application such as Excel, Word or Wordpad. There are several ways to export the required information:

- One or more records can be selected in the **Records view** tab and moved via “drag and drop” directly into another ‘visible’ application (provided that the application supports tab or comma separated formats e.g. Excel).
- A **table** or **graph** can be dragged and dropped into another application by holding the **Ctrl** key, selecting the item and dragging into the application.
- A **table** or **graph** can be copied by selecting the item then selecting **Edit-Copy**. The item can then be pasted into another application. Note that the edit menu selections available will depend on the contents of the report.
- Any of the parameters from one or more records can be exported as a text file. This file can then be loaded into a Word document or a spreadsheet. A template is used to specify which record parameters are exported. The **Tools-Settings-Data export templates** dialogue allows users to create and modify their own templates.
- A complete measurement file, or selection of records, can be exported using **File-Export...** Refer to the following section for details.

Exporting using Drag and Drop

As the name suggests, exporting data by “drag and drop” is simply a matter of dragging the records to another application and then dropping them.

Select a record then move the cursor to the boundary or edge of the record until a small rectangle and cross attaches. Press and hold the mouse button and drag the selected record(s) to the other application and release - i.e. drop.

The parameters exported will be those shown in the **Records view**.

The same technique can be applied when exporting tables or graphs.

Exporting using Menu controls

To export a complete measurement file, or selection of records, first open the required file and select **File-Export...**



Use the tabs - **File**, **Parameter**, **Settings** - and select the exporting options.

File tab

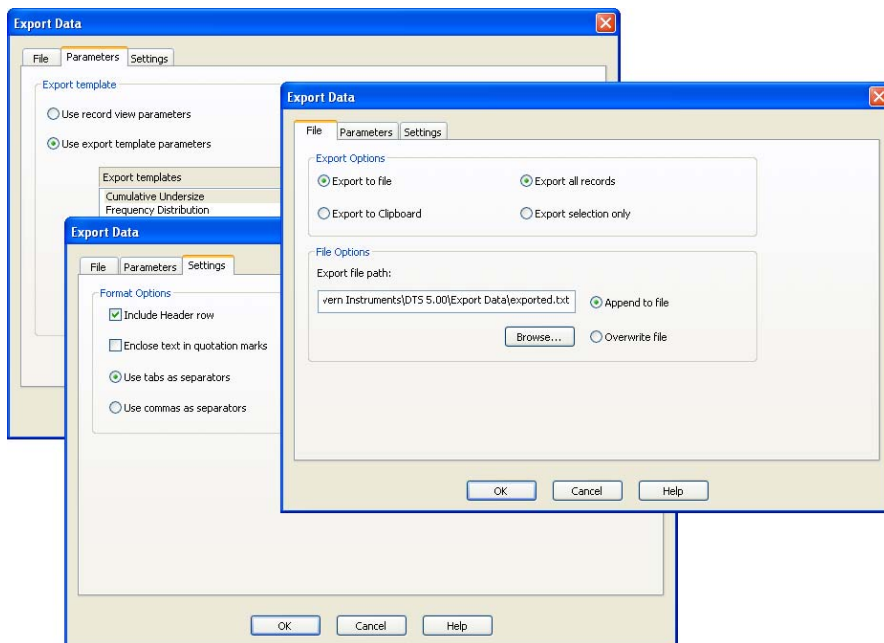
- The data can be either **Exported to file** or **Exported to Clipboard** by selecting the appropriate radio button.
- To **Export to file**, type the destination filename into the **File options** selection box and decide whether to **Append** (add) to the existing file or **Overwrite** it. Overwrite will delete any previous measurement results so only the last measurement will be available.
- **Export to Clipboard** will **copy** the data into the ‘clipboard’, where it can then be **pasted** into another application. The **File options** selection box will be greyed out when this option is chosen.
- **Export all records** will export the complete measurement file, whereas **Export selection only** will export only the records that have been highlighted.



Parameters tab

This enables exporting of selected parameters. Selecting **Use records view parameters** export parameters currently displayed in the Record view. User defined parameters can be exporting by selecting **Use export configuration parameters** and choosing the required template. If necessary, a new template can be created  or an existing one edited . This will be discussed later in this chapter - **Creating an export template**.

Settings tab

This tab determines how the data are exported. The **Format options** specifies the separator character that is used between each parameter.

Different spreadsheet packages require different field separation characters to correctly space the data output. Commas are the most usual but these should not be used if they are numerical separators in the localised Windows version.

Creating an export template

New export templates can be created (or existing ones modified) by selecting **Tools-Settings-Data exports templates**, and using the associated dialogue, shown here.

Two export templates are supplied as standard: **Cumulative Undersize** and **Frequency Distribution**.

To create a new export template select **New (insert)**  and type in a name. The name of a template can be changed by double-clicking the cursor over the name and typing a new one.

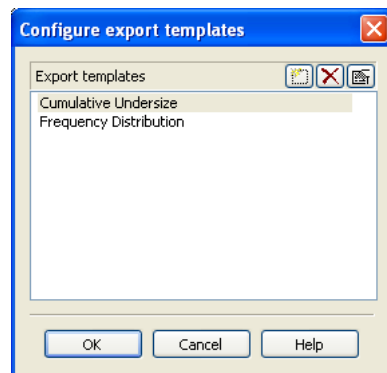

Once created, a template can be highlighted and either altered by pressing the **Edit**  button, or deleted by pressing the **Delete**  button.

When the **Edit**  button is pressed the **Export data** dialogue below will appear: only **Settings** and **Parameters** tabs are available.

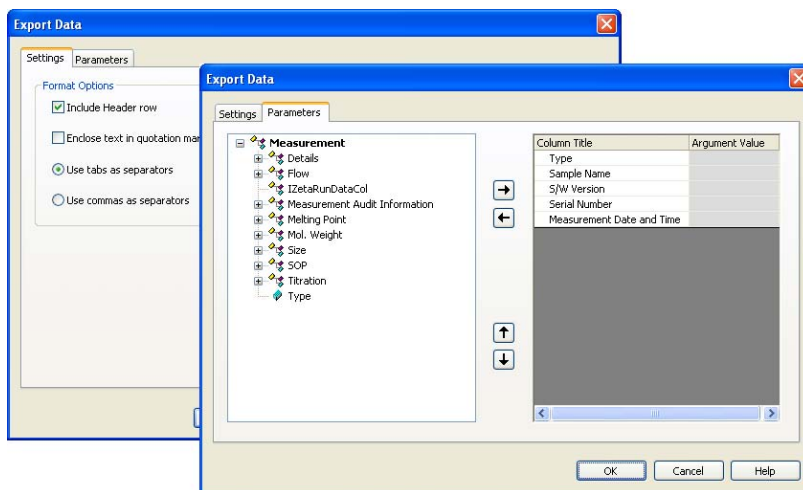

Settings tab

The settings tab works in the same way as previously described.

Parameters tab

- The list on the left displays all available parameters.
- The list on the right displays all parameters that will be included in the export template.

Parameters can be added or removed from this list by using the **Add** and **Remove**  keys.

Change the order in which the parameters are displayed by selecting a parameter, and using the **Move up** or **Move Down**  buttons.

Press **OK** to exit and return to the **Configure export templates** dialogue. Press **OK** again to save the template.

Parameters with arguments

Certain parameters allow specific values (or arguments) to be added.

Column Title	Argument Value
Type	
Sample Name	
S/W Version	
Serial Number	
Measurement Date	
Z-Average	
PDI	
Sizes	
Undersize By Intensity	
Undersize By Volume	
Dv(90)	
D(v) argument (0 to 1)	0.90

A Dv(90) percentile can be viewed by adding **Measurement-Size-D(v)** and then typing 0.90 as the argument value.

Column titles can be altered by double-clicking on them e.g. double-click on D(v) and alter to Dv(90) to reflect the particular percentile size viewed.



Note

The Export templates can also be selected and edited using the SOP creation procedures - **Export** dialogue.

Flow-mode

The **Flow-mode** option allows the Zetasizer μV to be connected, using a flowcell, to a flowing sample stream, such as the output of a chromatographic column, and measurements made without interrupting the flow.

In a flow-mode measurement, both the scattered light intensity and hydrodynamic diameter are plotted as a trend.

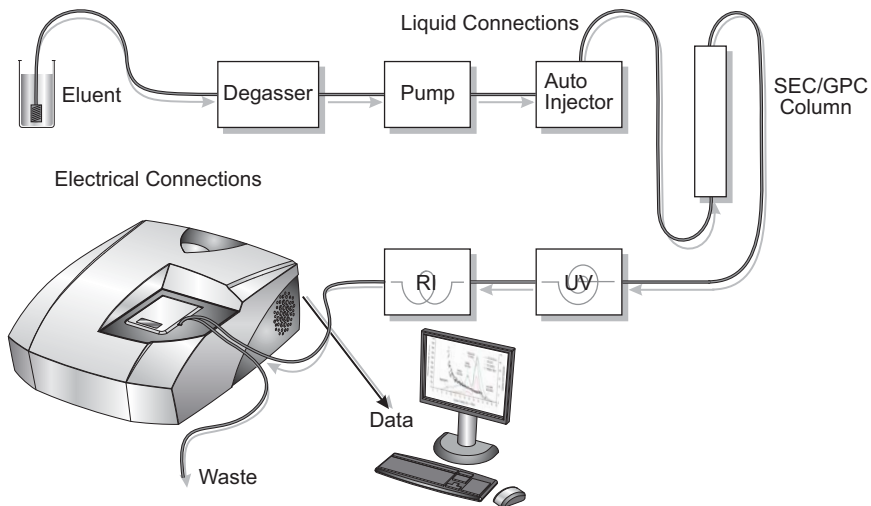

iii 8331

Applications

Applications for this feature include use as a chromatography detector and a process monitor.

Chromatography detector

When connected to a chromatography column, the Zetasizer μV acts as a sensitive light scattering detector, simultaneously plotting trends of the total intensity of light scattered, and the size as the hydrodynamic diameter.

Light scattering is an almost universal detector as most materials, such as proteins for example, will have a different refractive index to the buffer they are in, and hence will produce a light scattering signal.

Editing and inspecting a Flow-mode result

A flow-mode result can be edited by right-clicking on the measurement record and selecting **Edit-Result** (see the **Editing a Result** section earlier in the chapter). This will display the dialogue below.

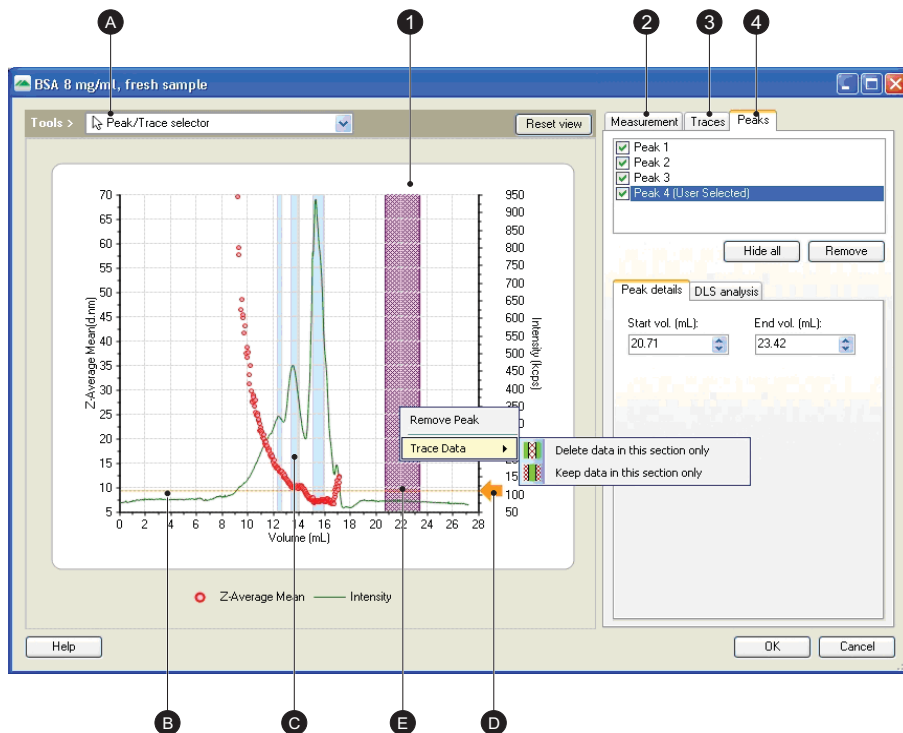

The dialogue shows the following:

ill 8209

① Flow-mode plot

This shows the flow-mode plot. By default the **Z-average mean** trace is always displayed on the left y-axis, with a second selectable parameter displayed on the right y-axis. Right-clicking on the y-axis text allows other available traces to be displayed. The available traces are displayed in the **Selected trace** area of the **Traces** tab.

Ⓐ Traces

The traces on the plot display the measured parameters with respect to the volume passed through the flow-mode system arrangement. Use the cursor to select each trace; the trace selected will be displayed in the plot legend and the displayed **Trace** tab.

The traces shown can be chosen by right-clicking on the y-axes or by using the **Trace** tab.

Generally the **Z-average mean** values are shown as dots on the plot, whilst the **Intensity** is shown as a continuous line.

Ⓑ Peaks

The **peaks** detected by the analysis are indicated by the **blue vertical bars** on the plot. The peaks displayed are determined by inspecting the Z-average mean data points.





When a peak is selected, by either clicking on the bar or selecting the peak check box, the **Peak** tab will be displayed. This shows the peak details (see below). Note that the selected peak will be highlighted deep blue.

Ⓒ Viewing tools

These enable different plot views to be shown. The tools can be selected and used in two ways:

- Select directly from the drop-down menu and perform the action.
- With the drop-down menu showing the Peak/trace highlighter, hold the appropriate control key down to perform the action.

The actions available are:

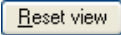
Name	Icon	Key	Action
Peak / Trace highlighter (cursor)			When the cursor is moved over the traces, peaks and axes of the plot, this will change to a hand, allowing the feature to be selected. When a trace or peak is selected the respective tab will be displayed.
Zoom		Alt	Use to place a "marquee" around a specific part of the plot and enlarge. The axes will automatically adjust to match the enlarged plot.
Scale		Control	Use to dynamically zoom in or out of the plot. This will be centred on the cursor position. The axes will automatically adjust to match the new scale.
Pan		Shift	Allows the plot to be moved left, right, up and down. The axes will automatically adjust to match the new position.
			Resets the view back the initial view. All zoom, scale and pan actions will be removed.

Ⓧ Baseline pointer

The **Baseline pointer** is used to set the datum level for the plot. When the measurement is originally performed the software will attribute an appropriate baseline level and use this as a filter to remove unwanted and erroneous data. All measurement data below this level will be removed from the measurement, plus any data above it that the software considers to be uncharacteristic of the measurement, in effect an “outlier”.

With reference to the originally attributed baseline level, the software will display any peaks that may have occurred during the measurement.

To observe the effect on the peaks when the baseline is adjusted, change a y-axis to **Intensity**, select the baseline pointer with the cursor and drag to a different position along the right y-axis. The peaks will be displayed in the **Peaks** tab (see below) - this will automatically be displayed when the baseline pointer is moved.

Note that when the baseline level is moved the software will remove any data that is below the new level. This may significantly alter any peaks shown.

The baseline pointer is only visible when an **Intensity** trace is displayed.

Ⓧ Remove Peak

Sections of the chromatogram can be removed from the flow-mode plot. To remove a part of the chromatogram, highlight a section by dragging the mouse over the graph; then right-click on the highlighted section and select **Trace data**.

Options will be given to either remove the highlighted section (**Delete data in this section only**), or to remove all data outside the highlighted section (**Keep data in this section only**).

② Measurement tab

This **Measurement** tab displays the measurement details. These are the same details as entered when the measurement was first performed. Refer to the appropriate SOP dialogues - **Sample** and **Flow settings** - for more details.

The **Edit settings** button will display the standard **Edit result** dialogue where the measurement details and parameters can be inspected and edited.

③ Traces tab

The **Traces** tab displays the traces available for viewing on the plot. The traces available will be determined by the flow-mode system arrangement and the measurement signals analysed.

The available traces could be the **Z-average mean**, **Intensity**, **RI** (Refractive Index) and **UV**. When **RI** is selected using the drop-down menu, the **Delay Volume**, **Offset** and **Gain** values will be displayed; These are the values entered in the **External Inputs** SOP dialogue when the SOP was originally performed. Refer to the **Flow-mode SOPs** section in **Chapter 9**.

Note that the default **External Inputs** values are defined in the **Options** dialogue, explained later in this chapter.

④ **Peaks tab**

The **Peaks** tab displays all the details about the calculated peaks shown in the flow-mode plot. To display a peak's details either select a blue peak bar in the plot, or select one of the peaks identified at the top the peak tab; the details in the tab will reflect the data appropriate to that peak. The selected peak will be highlighted on the plot.

The details displayed are the same as shown on the **Chromatogram summary** report.

The features of the **Peaks** tab are:

- **Peaks identified** box - this shows all the peaks identified in the measurement and plot. Selecting a peak will display its details in the accompanying boxes.
To show or hide a peak in the plot, select or de-select the check box alongside the peak.
- **Hide all** - press this button to hide all identified peaks. Peaks can be displayed again by selecting the peak check box.
- **Remove** - this will remove the highlighted peak in the Peaks identified box. When pressed, a message will appear to warn that the peak will be removed permanently.
- **Start vol. / End vol.** - this shows, in mL, the start and end volume points for the peak.
- **Peak analysis details** - displays the results from the measurement: **Molecular weight**, **Z-average**, **Width** and **Intensity area**.

Options dialogue

The **Options** dialogue enables extra features and programs for the Zetasizer software to be installed, and to configure the default folder for saving of data.

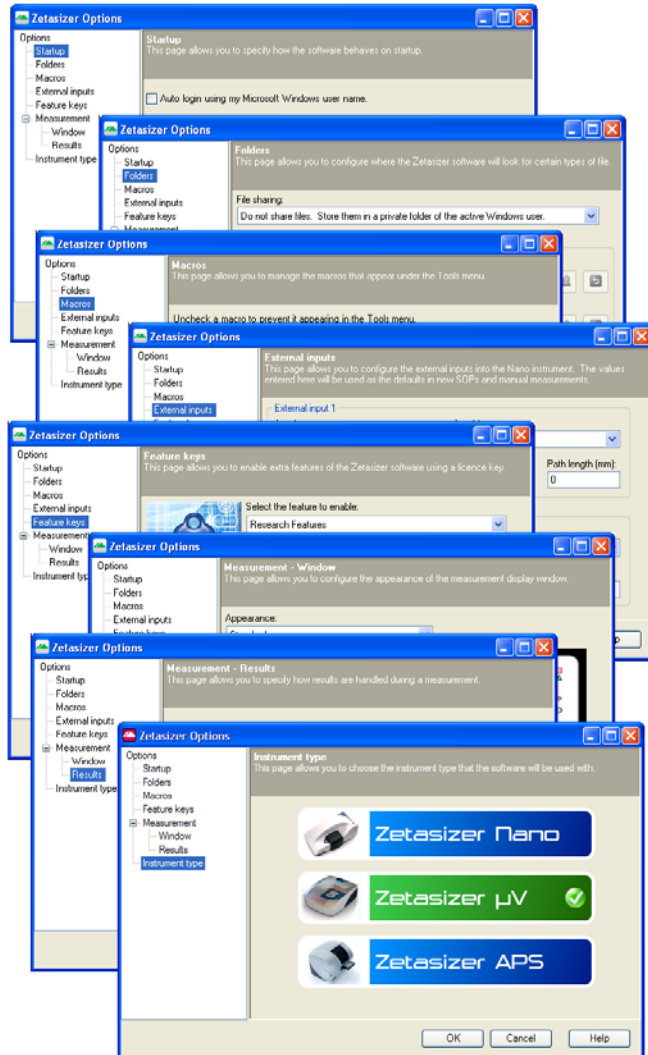

The **Options** dialogue enables extra features and programs for the Zetasizer software to be installed, and to configure the default folder for saving of data.

To open the Options dialogue, select **Tools-Options...**

The features available from the menus are described below.

Options



Startup

The Startup option specifies how the software will behave on startup. Either using the Microsoft Windows password to logon with, or one specific to the application software.

Folders

The **Folders** dialogue indicates and defines where the measurement data, SOPs and Export data are saved to. The Zetasizer software will look for certain types of file at these locations.

When the software is first installed, these file-paths will be configured to their **default** setting. This page allows the file-paths to be configured so the files can be saved to more appropriate locations.

- Pressing the  button allows another destination to be selected. This will open a **Browse for Folder** dialogue; select the new destination directory and press **OK**.
- When the file-path used is different to the default, the second button alongside will turn blue ; pressing the button will revert the file-path to the default location.

Macros

Additional and customised software programs can be added and installed by using the Macros option. This dialogue allows new macros programs (.zmac files) to be installed and selected.

The Macro programs are written by Malvern to enable the system to operate in a mode required for a specific application. Highlighting the Macro in the left box will display the Macro details in the right box.

Any installed and selected macros will be seen in the **Tools-Macros** menu (the list below is shown only as an example).

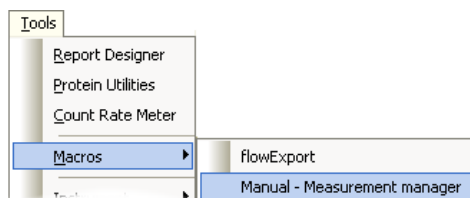

- Press the **Install new macro...** button, select the macro from its location (CD, floppy disc, computer folder, etc.) and press **Open**. This will copy the macro

to the **zetasizer/macros** directory and add the macro to the list of available programs.

- To **display** the Macro in the **Tools-Macros** menu, select the **check box** alongside the macro and press **OK**. When the **Tools-Macros** list is next viewed the macro will be available to use. Any un-checked macros will **not** be seen.
- **Uninstall Macro** will remove the macro from the computer. A warning message will appear to indicate the macro will be deleted: **“Are you sure you want to delete the selected macro?”**.

Feature keys

This page allows additional features of the Zetasizer software to be enabled using a licence key. Extra features available include **Research** software and **21 CFR Part 11** capability.

- Enabling is done by typing the licence key number supplied into the entry box and pressing the **Install Licence key** button.

Full details on installation and enabling will be sent with each additional software package.

Measurement

Window

This option allows the appearance of the measurement display to be changed and selected. The appearance choices are shown below, for each one an anti-aliasing view is also available.

Standard

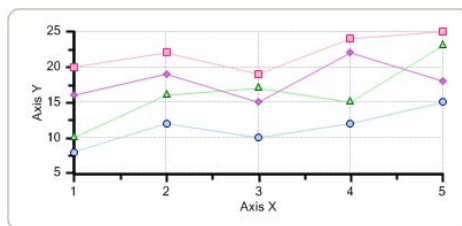

Style 1

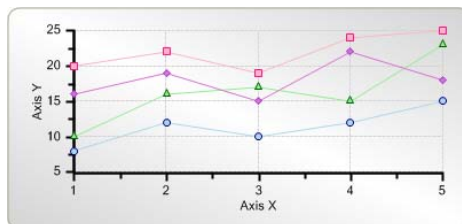

Style 2

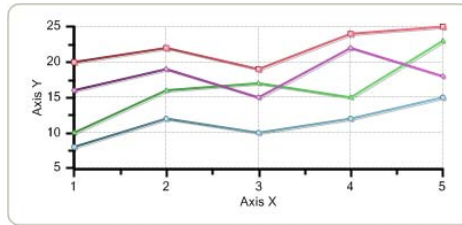

Style 3

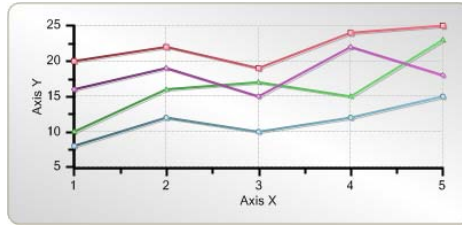

Results

This dialogue contains a check box that will allow measurements results to be saved even if the measurement is aborted before the measurement has finished collecting and analysing the data.

Instrument type

This dialogue provides the option to select which instrument type is currently in use. The software remembers the selection and uses the same mode the next time it is initialised.

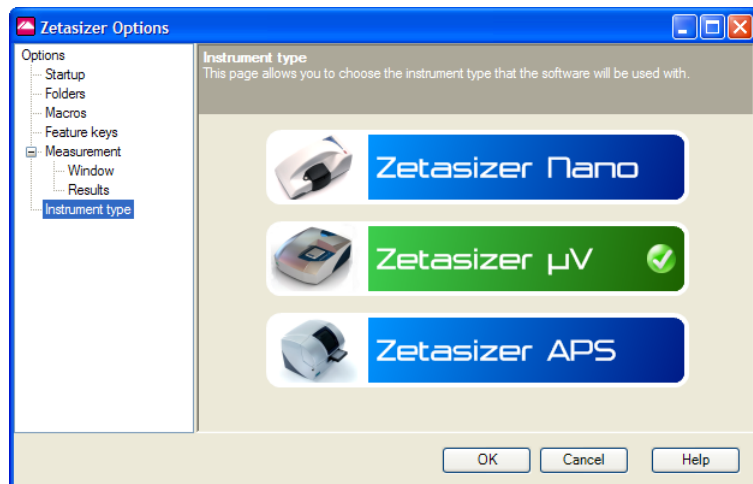

Expert Advice

Expert Advice enables a quality check to be performed on one or more completed measurement records. This will show how good the measurements are and whether they display any unwanted attributes, such as aggregation.

To enable the Expert System, choose **one or more** records, **right-click** on the **records** and select **Expert Advice**, or select **View-Expert Advice**. This will display the **Expert Advice** dialogue indicating the quality of the measurement. Advice may be given about how to rectify a poor measurement.

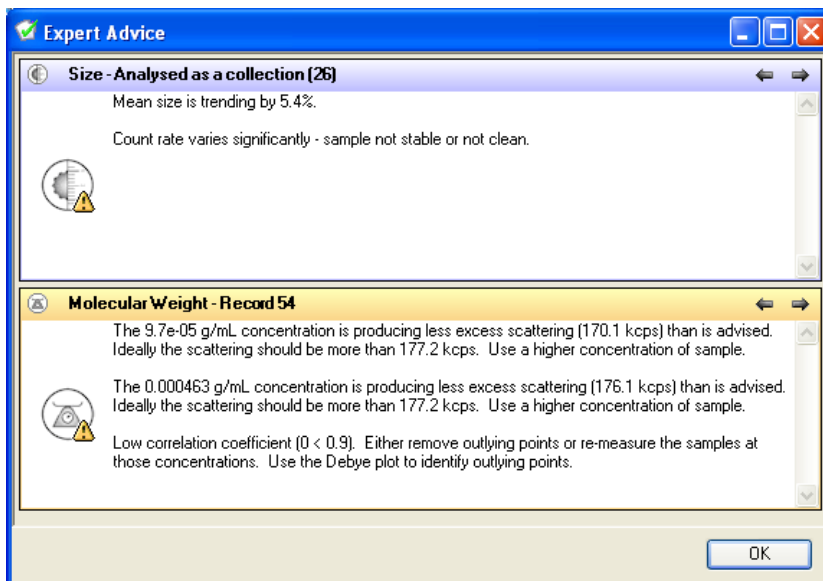





Explanation

In the above example Size and Molecular weight measurements have been selected. The quantity of records selected is indicated in the measurement header line (i.e. **Size [26]**).

The quality of the records chosen is indicated by either a **green** circle - for a good measurement, or an **amber** triangle for a poor or unacceptable measurement. This is followed by a brief description of the measurement quality and **tips** for improvement.

The sentence shown in the measurement title lines above - **Analysed as a collection** - indicates that the records selected for the expert system to look have been analysed as one. To see each measurement records advice individually, use the

← and → arrows to step through each record in turn. The record being inspected will then be indicated in the measurement type title line; e.g. **Record 39**.

Measurement type	Good Measurements (green circle)	Poor or unacceptable Measurements (Amber triangle)
Sizing		
Molecular weight		

**Note**

An **Expert Advice** tab is also available in the **Measurement display**. This enables the quality of the measurement to be inspected as it progresses.

Creating Custom Reports

Introduction

This chapter describes how to use the **Report Designer** to design custom reports. These can display parameters which are not on the default reports.



Note

The Malvern Instruments default reports described in **Chapter 5** will be sufficient for most users. These are identified with (M) appended to the name - e.g. Intensity PSD (M))

This chapter covers:



- An overview of screen and page layout views, what a report contains, and how to start the **Report Designer**.
- Opening an existing report.
- Creating a new report.
- Adding elements to the report.
- Setting up the report elements.
- Selecting elements.
- Aligning and sizing elements.
- Saving a report.
- Viewing the new report.
- Other information shown on a report.
- Protecting a report.

Overview

This section introduces the Report Designer.

Views

Two views must be created due to the different aspect ratios of the printed page and computer screen:

-  **Screen Layout** – shows the computer screen version.
-  **Page Layout** – shows the printed version. This tailors the same contents to the dimensions of the printed page.

The two views do not have to be identical; for example, company logos can be added to the printed reports but not shown on the screen display. Both views are saved in the same **.pag** file.

To change either layout, right-click on the screen and select **Properties**. For the page layout this allows changes to paper size, portrait/landscape orientation and margins. For the screen layout the screen size can be changed.

Report contents

The report can contain one or more of any of the following elements:

- **Text** – user-defined text.
- **Picture** – graphics files can be added to customise the report.
- **Frame** – used to separate parts of the report, this inserts a border around an area.
- **Parameter** – any parameter stored in a record can be added to the report.
- **Calculation** – custom calculations using system parameters. These can be used to provide pass/fail decisions.
- **Graph** – data in a selected record can be added to the report in the form of a trend graph or distribution graph.
- **Table** – a table summarising a required parameter.

These are added using a **Control Palette** toolbar.



Note

During creation of a report data from the current record(s) is used. If no record is selected dummy data is used.



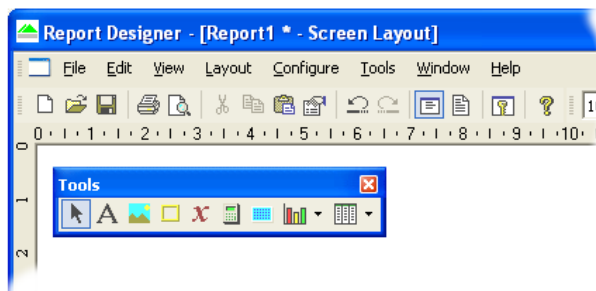

Getting started

To open the **Report Designer** select **Tools-Report Designer**. The **Report Designer** opens in a separate window as shown below.

In this example the small **Control palette** has been dragged from the toolbar to make it easier to use. This tool can be used in either position, depending on the user's preference.



These **Edit** menu commands are of general use:

- **Edit, Copy and Paste** – allow copying and pasting of text and graphics from other programs. The    toolbar buttons have the same function.
- **Undo** () and **Redo** () – for undoing or repeating commands, respectively.

Opening an existing report

To open an existing report use the **Report Designer's** menu command **File-Open....** Report files have the extension **.pag**.

Creating a new report

A new report can be created in two ways:

- Selecting **File-New** from a blank page and adding the report contents.
- Opening an existing report, editing it, then saving it with a new name.

For both methods the procedure for designing a report and customising its content is the same.

Adding elements to the report









This section shows how to add elements to a report, select any of these elements and move or align them on the screen. Add all the required elements to the report then move them to the correct positions before going on to the next stage.

The **Control palette** is used to design reports:



The palette can be moved anywhere on the screen. It can be switched on and off using the **View-Control Palette** command on the **Report Designer** menu.

Use the following buttons on the palette to add the listed elements to a report:

Button	Use this to add:
	Pointer - select elements.
	Text.
	Picture.
	Frame – used to split the report into sections.
	Parameter.
	Calculation.
	Well-plate - for use with Zetasizer APS results.
	Graph – use the list button to select a Trend graph, or a Distribution graph.
	Table – use the list button to select a Trend table, or a Distribution table.

► To add an element:

1. Click one of the above buttons.
2. Move the cursor away from the palette. When the cursor changes to a “+” shape, hold the left mouse button down and drag the cursor to draw a rectangle on the report. This is called a **marquee**.

- When the mouse button is released, the marquee receives the selected element. This will be marked initially by a hatched border like those shown below. This shows that the element is currently selected:

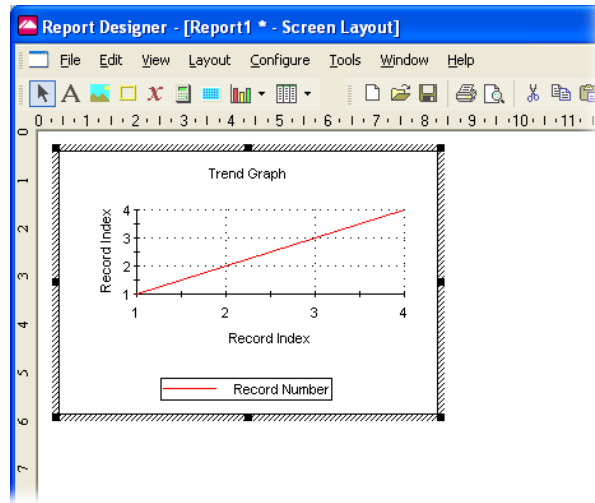

- Use the cursor to drag the selected element or the black resize handles around its border to resize the element if necessary.
- Right-click on the element and use the menu this displays to configure its properties, as described below.

Setting up the report elements

Set the properties of any added element by selecting it and double-clicking to open the **Properties** dialogue box. The on-line help in these dialogues details how to use each one. The sections below show the properties each type of element has.



Note

This dialogue can also be opened using **Edit-Properties**, by right-clicking and selecting **Properties**, or by typing **Alt-enter** on the keyboard.

Text

Use the **Text** tool to add general text such as a report name to the report.

With the element selected, use its **Properties** dialogue to edit the text and its style (including its alignment), colour and size. Edit text or type new text using the **Caption:** box on the **General** tab.

Picture

The **Picture** tool is generally used for company logos, etc. All the main graphics file formats are supported.

With the element selected, use its **Properties** dialogue to browse for the picture to insert. Use the **Keep Aspect ratio** check box if required to maintain the aspect ratio of the original image. Use the **Link to file** check box to link to rather than embed the file; this means that when the file is updated the contents of the report change too.

Parameter

Use the **Parameter** tool to display measurement variables such as **Dv90**, **SOP Name**, etc.

The parameter **Properties** dialogue has the same tabs as the text dialogue, plus a **General** tab to specify what the parameter is, as shown below:

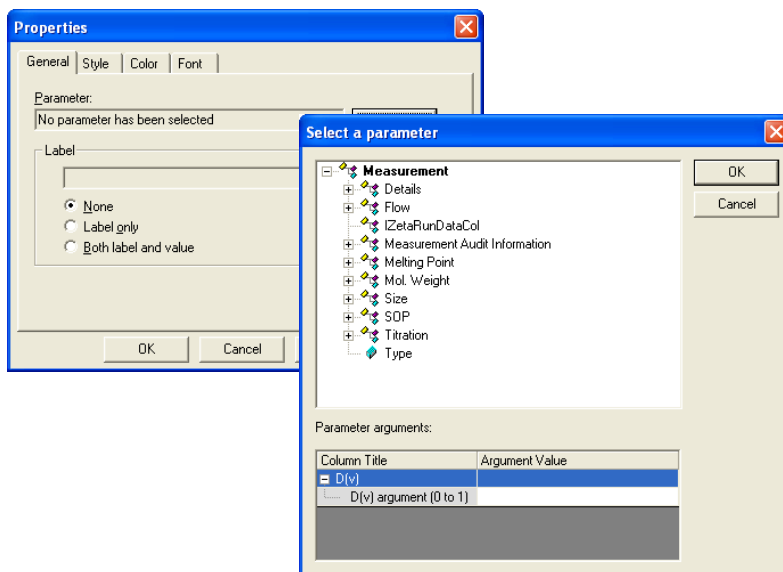

On the **General** tab click the **Select** button. In the **Select a parameter** dialogue select the appropriate parameter (see below) and click **OK**.

Use the **Label** selection area to add a parameter label alongside the parameter value. The style, colour and font of the label and value can also be defined here.

Parameters with arguments

Certain parameters allow specific values (or arguments) to be added.

A Dv(90) percentile can be viewed by double-clicking the cursor on **Measurement-Size-D(v)** and then typing 0.90 as the **Argument value**.

Parameter titles can be altered by double-clicking on them e.g. double-click on D(v) and alter to Dv(90) to reflect the particular percentile size viewed.

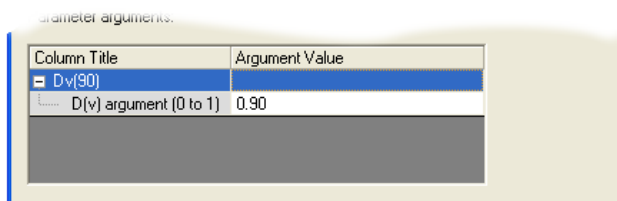

The **Label** selection area enables the parameter name to be added alongside the parameter value.

Frame

Use the **Frame** tool to split the report into relevant sections.

With the element selected, use its **Properties** dialogue to select the frame style – etched, raised, sunken, etc. – or change its colour.

Horizontal and vertical lines can be inserted into the report to divide sections.

To stop a frame overlaying other elements, right-click on it and select the **Send to back** option.

Calculation

In addition to the defined parameters described in the parameters list, custom calculations can be entered. This is useful for displaying “Pass” and “Fail” criteria for measurement parameters. New “derived” parameters can also be created. With the newly created element selected, use its **Properties** dialogue to configure the calculation.

The **Properties** dialogue is similar to that for a text element, but with the addition of a **General** calculation tab that enables editing of the calculation. Press the **Edit** button to open the **Calculation Editor**.

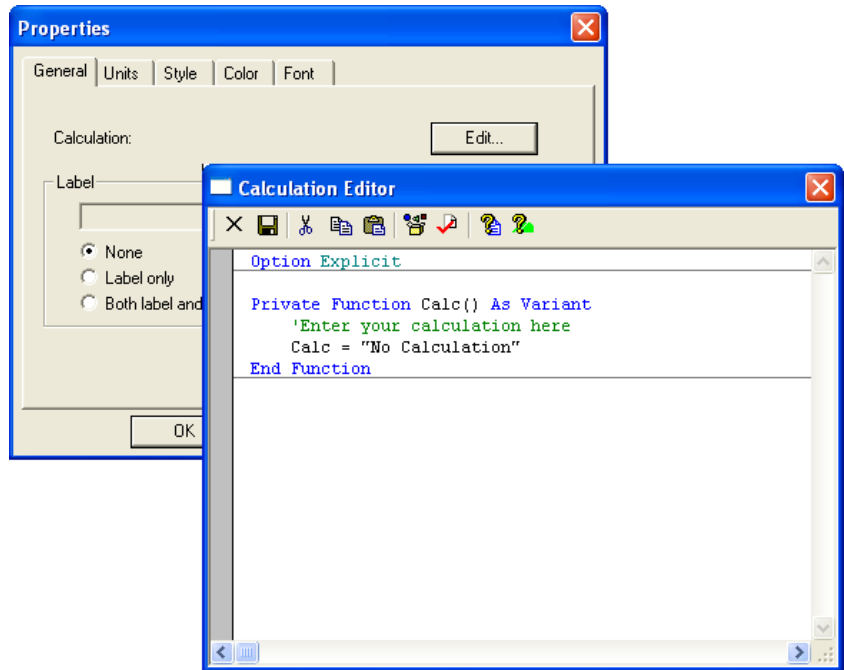



Calculation Editor

Use the **Calculation Editor** to load an existing calculation for editing or to create a new calculation. The language used, Sax Basic, is similar to Microsoft Visual Basic for Applications (VBA).

Select the browse icon  to choose functions from the library lists, which can be used to build up calculations. All details about a measurement and how it was performed can be accessed in the available data type lists, i.e. size results, measurement and result details.

More information is available from the **Calculation Editor** help buttons:

Button	Function
	Describes the Sax Basic language.
	Describes how to use the Calculation editor .

Graphs

A number of data graphs can be added to a report using the **Report Designer** control palette.

Select the graph icon and then choose one of the following graphs from the drop-down menus. The menus are split into **Trend**, **Titration**, **Size** and **Molecular weight** with accompanying graph choices.

Trend graphs

Trend graphs allow the measurement data from multiple records to be compared to investigate any trends in the information. Any parameter can be chosen for the X-axis, and any two other numerical parameters for the Y1 and Y2 axes.

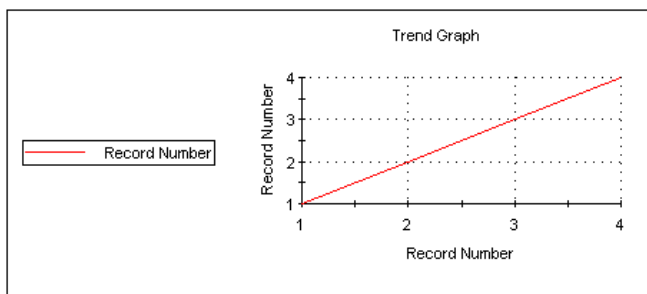

Size graphs

The following size graphs can be inserted.

Result

This shows the size result of the measurement. It can be displayed in different ways using its **Properties** box.

Correlogram

Displays the correlation function, which is the output of the contents of each of the correlation channels.

Residuals

This is the plot of the difference between the actual correlation function measured and the correlation function that is back calculated from the size distribution displayed.

Statistics

The statistics graph will show the mean, standard deviation, maximum and minimum of a group of selected measurement records. The statistics shown on the table can be altered using the **Properties** dialogue.

Fit

This is an overplot of the actual correlation function measured and the correlation

function that is back calculated from the size distribution displayed. The closeness of the fit is an indicator of the success of the algorithm used and the quality of the measurement.

Cumulants fit

Plots the difference between the correlation data and the polynomial that is the best fit to that data.

Cumulants residuals

Shows a plot of the difference between the cumulants fit and the measurement data.

Z Average trend

Shows a plot of the Z-average against selected records.

Melting point

Displays the temperature at which the Melting point is achieved.

Molecular weight graphs

The following Molecular weight graph can be inserted.

Debye

Displays the calculated Molecular weight as a Debye plot - the variation in intensity versus the concentration.

Graph properties dialogue - general

This dialogue allows the attributes of the graph to be altered.

- **Display** or **Option** – Depending on the graph type inserted, **Display** or **Option** will appear in the **Properties** dialogue.

The **Display** tab allows a choice of graph type and how it is to be displayed, i.e. as a histogram or curve.

The **Options** tab (or selection box in the above **Display** tab) allows the graph key position to be chosen. A graph tips option enables pop up tips (flags showing data points on the graph to appear on the report (not on the screen shown in the Report Designer).

- **Axis settings** – Allows both the X and Y axis settings to be defined. Whether **logarithmic** or **linear** axis are required and the axis scales - defined or auto-scaling. **Gtricule** (or grid) lines can also be shown on the graphs.
- **Font** – Allows the font style to be altered. The setting will apply to all annotations used on the graph.
- **Upper/Lower limits** – Further tabs allow the setting of **Upper** and **Lower** warning or action **limits**. The value shown is checked to be within the limits.

Trend graph properties

For a **Trend** graph the **Properties** dialogue has a **Properties** tab for selecting the parameters to view:

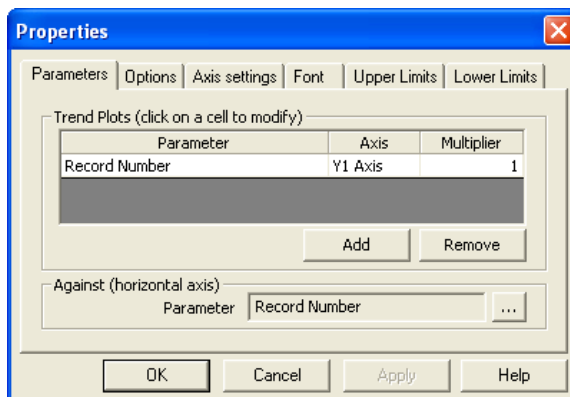

The **Trend plots** selection area is used for selecting the Y axes parameters. The Y1 parameter column is used to select the axis on the left of the graph and Y2 to select the axis on the right.

To choose a parameter press the **Add** button, select the appropriate parameter and press **OK**. Either highlighting the chosen parameter and pressing the **...** icon, or double-clicking the parameter will again display the **Select a parameter** dialogue.

Use the **Against** area to select the X axis parameter.

Line styles

Select **Configure-Line styles** to display a line styles dialogue. This enables each measurement result line in a graph to be either coloured, increased in thickness or have its line style changed.

Select the **Line style** from the list and use the **Symbols** tab to alter the symbols used for data points as required.

Tables

A number of data tables can be added to the report using the control palette. The data is taken from the current selected measurement record, or group of selected records for the trend and statistics tables.

Select the table icon and select one of the following tables from the drop-down menu. The menus are split into **Trend**, **Titration**, **Size** and **Molecular weight** with accompanying table choices.

Trend tables

Trend tables allow the measurement data from multiple records to be compared to investigate any trends in the information. Any two numerical parameters can be compared.

Size tables

The following size tables can be inserted.

Result

This shows the size result of the measurement. It can be displayed as Size/Intensity, Size/Volume and Size/Number using its **Properties** box.

Statistics

The statistics graph will show the mean, standard deviation, maximum and minimum of a group of selected measurement records. The statistics shown on the table can be altered using the **Properties** dialogue.

Molecular weight tables

The following Molecular weight table can inserted.

Debye

Shows the data used to generate a Debye plot in a tabular format.

Table properties dialogue

This dialogue is the same as that for the **text** dialogue, plus a **Table** tab that defines the type of table displayed and how many columns to use. The **Trend** table properties dialogue also contains a **Trend** Parameters selection area from which the required parameter can be selected - press the **Add** button, select the appropriate parameter and press **OK**. Refer to the **Parameters properties dialogue** for more details.

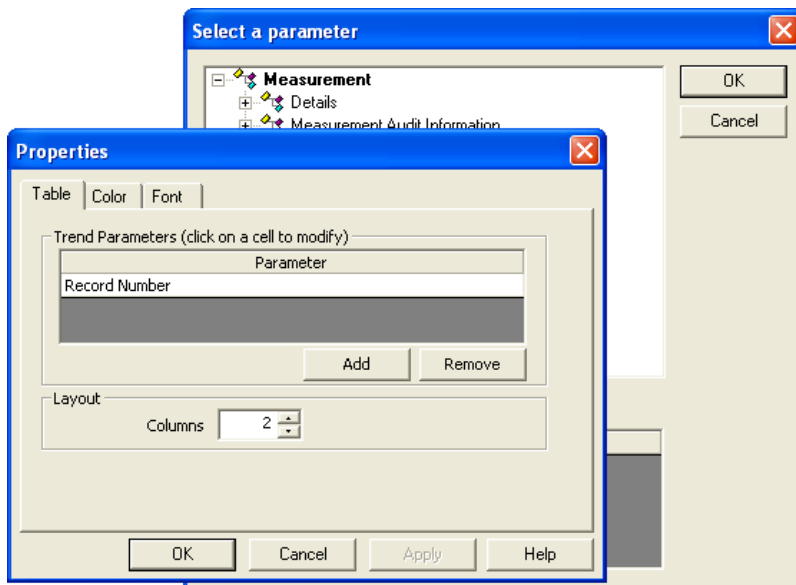

Any available parameter can be selected and inserted into the report. The parameter value displayed is taken from the selected measurement record.







Selecting elements

When selecting elements:

- To select one element, click on it.
- To select multiple elements, hold down the **Shift** or **Ctrl** key and click the mouse button on each element in turn. Alternatively, hold the left mouse button down and drag a box (**marquee**) over a group of elements.
- If one element is overlaid by another and cannot be selected, select any element and use the **Tab** key to step through all the elements one by one until the correct element is selected.

Aligning and sizing elements

Select two or more elements and use the following options of the **Layout** toolbar or menu to align/size them:

Button	Function	Button	Function
	Layout-Align-Align left		Layout-Make Same Width
	Layout-Align-Align right		Layout-Make Same Height
	Layout-Align-Align top		Layout-Make Same Size
	Layout-Align-Align bottom		

The **last** element selected, highlighted with **eight dark squares**, provides the reference position for alignment. The **Layout** menu also has commands to:

- **Space Evenly** several elements and **Centre** an element.
- **Send to front** or **Send to back** the selected element (when two or more elements are overlaid).



Note

Right-clicking on a selected element also brings up the layout options.



Saving a report

To save a report select **File-Save...** and save it in the **Report Pages** directory. It must be in this location if it is to be available for inclusion in a workspace. Reports are saved with the default file extension **.pag**.

If the report was designed solely in **Screen Layout** view, a prompt appears, advising that the **Print Layout** version is blank. In **Screen Layout** view select **Edit-Select All** and then **Edit-Copy**. Use **View-Page Layout** and then **Edit-Paste** to copy the content into the printed report page. If the printed layout is to be different from the **Screen Layout** version, make the changes here. All that is then required is some rearranging and formatting to line up all the elements.

A finished report

ill 6588

Using the tools described above a custom report can be created. For example a printed **Page layout**  is shown below with the corresponding **Screen layout**  alongside. The dotted lines indicate the edge of the printed page.

Remember if the custom report is to be printed then a **Page** version must also be created. Both screen and page versions of each report will be saved in the **My Documents\Malvern Instruments\Zetasizer\Reports...** directory.

An easy way to create a screen report from a page report (or vice versa) is to use **Edit-Select all** from the menu, then copy and paste the complete page from the printed layout and directly paste into the screen version; all that is then required is some rearranging and formatting to line up all the objects.

Viewing the new report

- ▶ To view a newly saved report in the main Zetasizer μV window:
 1. Select **Tools-Settings-Configure Workspace** and select the workspace to associate the new report with.

2. In the **Report Pages** tab select the check box for the newly created report. Click **OK**.
3. When the appropriate workspace is selected, the report will be shown as a tab in the measurement file window. Click the tab to see the report.

**Note**

If a report that is currently displayed by the main application is edited, saving the edited report immediately refreshes the view in the main window. Any changes made are shown immediately.

Other information shown on a report

The printed copy of a report shows the software version number and instrument serial number at the bottom of the page. This is important information if a call is made to the Malvern Instruments help desk. The name of the measurement file the report is based on is also shown.

Protecting a report

A report can be locked with a password to prevent unauthorised changes.

► **To password-protect a report:**

1. Open the report in the **Report Designer** and select **Tools-Protection-Protect report...**
2. A dialogue appears asking for a password to be entered and confirmed. Write the password down in a safe place as it will not be possible to edit the report without supplying it.
3. Click **OK**.

Protein Utilities

Introduction

One of the basic functions of the Zetasizer μV is its ability to perform accurate measurements of a sample's Molecular Weight. By measuring the sample scattering intensity over a range of concentrations and enter the necessary sample parameters, the Molecular weight can be determined.

If the hydrodynamic diameter is also measured from one of these concentrations, the molecule shape or conformation can also be estimated.

The **Protein Utility** enables the calculation of the Molecular weight and also provides other calculation tools.

To access the Protein utilities select **Tools-Utilities-Protein utilities**. The following tab selections are available:

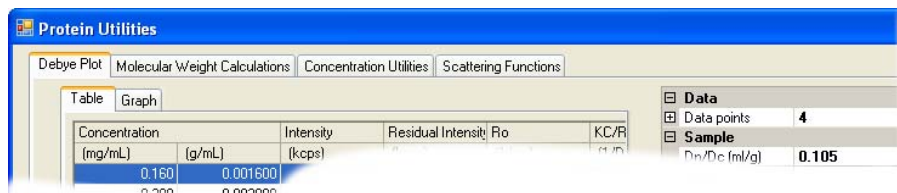

- **Debye Plot.** The protein utilities function enables a **Debye plot** to be constructed from freely available information, or from a record generated from actual data.
- **Molecular Weight Calculations.** A 'what if' calculation can be performed. If any two parameters from the **Molecular weight**, hydrodynamic size and conformation (**shape**) are known, then the third - either a Shape, Hydrodynamic diameter or Molecular weight parameter - can be estimated.

- **Concentration Utilities.** This dialogue contains features to establish the concentration and scattering levels that may be observed.
- **Scattering Functions.** A plot can be generated from entering the measurement data.

In each case the effect of changing any of the input parameters can be seen instantly in all of the derived parameters.

In this way it is possible to see directly the sensitivity of all the parameters required for the calculation on the result. This in turn will determine the accuracy of the instrumentation required to measure each parameter, for example the sample refractive index required to calculate the dn/dc value.

Debye plot

As mentioned in the introduction, the Protein utilities package includes the ability to generate a Debye plot, using inputted rather than measured data.

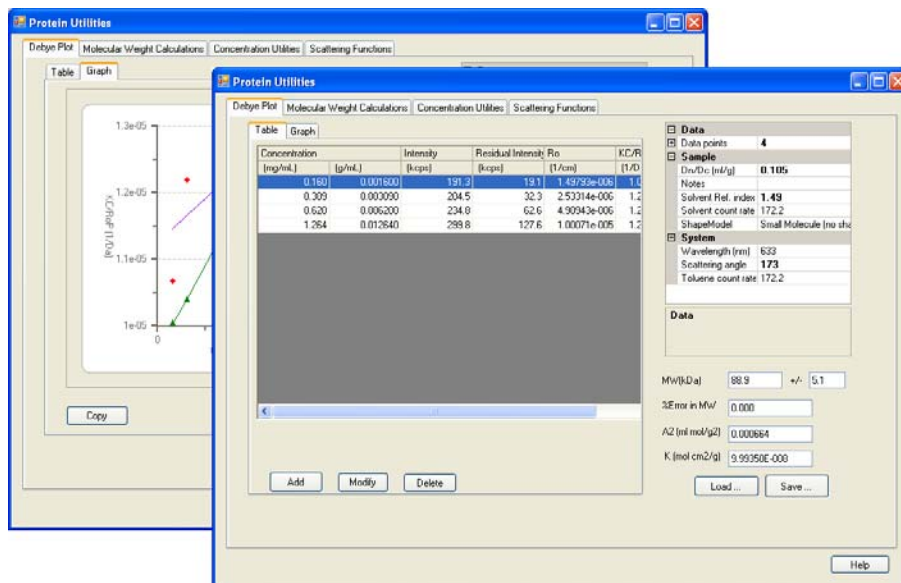

This feature can be useful for various reasons, for example:

- By combining individual measurements one single Debye plot can be generated
- A Debye plot can be created by entering the concentration points from an existing measurement, then adding additional concentration points.

- Any of the parameters in the dialogue box can be changed; the other parameters will be instantly recalculated. This can be used to investigate the sensitivity of the result to changes in any parameter.

For example, by first entering the concentration points from an existing measurement, a sample parameter - e.g. sample temperature - can be altered and the effect immediately observed on the Debye plot. This saves time in performing the original measurement again at the different temperature.

The format of the plot can be altered in the same way as the graphs in the main application, by moving the cursor over the graph and right clicking the mouse. The **Graph properties** dialogue will appear; refer to the **Size measurements - Graph** section in **Chapter 5** for details in altering the attributes.



Note

The Debye plot uses the reduced Rayleigh scattering equation as stated in **Chapter 14**.

Adding & editing sample parameters & table data

To generate a Debye plot, the sample parameters and table concentrations have to be entered.

To access the **Debye plot** select **Tools-Protein utilities** and then the **Debye plot** tab. Select the **Table** tab to begin entering data into the table.

Concentration		Intensity	Residual Intensity	Ro	KC/RoP	KC/RoP	
(mg/mL)	(g/mL)	(kcps)	(kcps)	▲ (1/cm)	(1/Da)	(1/Da)	
1.264	0.012640	299.8		127.6	1.00071e-005	1.26228e-004	1.262
0.160	0.001600	191.3		19.1	1.49793e-006	1.06745e-004	1.067
0.309	0.003090	204.5		32.3	2.53314e-006	1.21904e-004	1.219
0.620	0.006200	234.8		62.6	4.90943e-006	1.26205e-004	1.262

Adding data to, and editing the table

To access the **Debye plot** select **Tools-Protein utilities** and then the **Debye plot** tab. Select the **Table** tab to begin entering data into the table.

- To **define a new** concentration, press the **Add...** button. The table **Input values** dialogue will appear

Specify the **Concentration** and **Sample intensity** values - either new values or ones taken from an existing measurement.

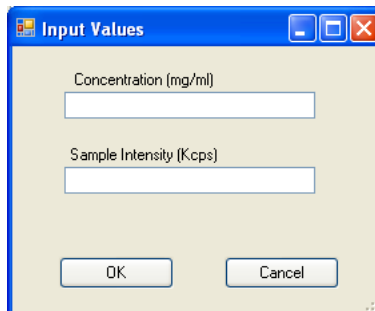

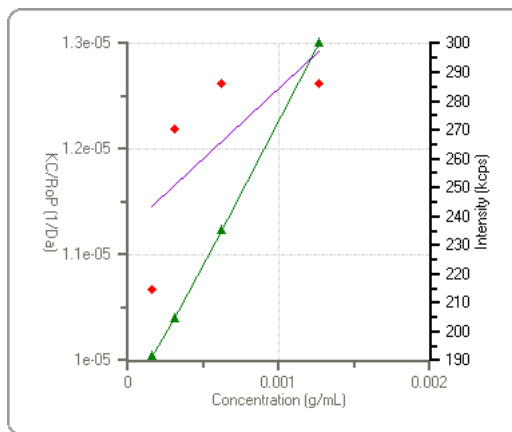

2. To **modify** a concentration, select it from the list and press the **Modify...** button. The **Input values** dialogue will appear, allowing the parameters to be changed.
3. A concentration can be **deleted** by selecting the concentration from the list and pressing the **Delete...** button.
4. Select the **Graph** tab to see the resultant **Debye plot**.



5. The table values and graph plot can be subsequently altered by changing the **Sample**, **Data** and **System** parameters in the measurement parameters table on the right of the dialogue. These parameters are described in the following section.

Measurement parameters table

Once all the concentration values have been added into the table, the measurement parameters table can be used to alter the result and Debye plot.

To view and alter each parameter setting, click on the plus  sign next to each parameter group to open the list (Click on the minus  symbol to close the list).

Default parameters are in “normal” type, altered parameters will be made **bold**.

☐ Data	
☐ Data points	None
☐ Sample	
Dn/Dc (ml/g)	1.05
Notes	
Solvent Ref. index	1.499
Solvent count rate	172.2
ShapeModel	Small Molecule (no shape c
☐ System	
Wavelength (nm)	633
Scattering angle	175
Toluene count rate	172.2

The parameters are described below.

Data

This indicates the data entries that have been entered into the debye plot table, see below.

Sample

Sample dn/dc (ml/g)

This is the differential refractive index increment; the change in refractive index as a function of the change in concentration.

Experiment notes

Used to record specific details about the experiment or calculation performed.

Hydrodynamic radius (nm)

The radius as measured using dynamic light scattering.

Solvent Ref. Index (Refractive index)

The refractive index of the solvent used.

Solvent count rate (Kcounts)

The count rate used to calculate the Rayleigh ratio (R_θ) is the 'residual' count rate, which is derived by subtracting the solvent count rate from the sample count rate.

Shape Model

The shape model that is used to estimate the radius of gyration from the hydrodynamic radius, and therefore calculate the angle dependent effects on KC/RoP for particles of sizes outside the Rayleigh region (Diameter > ~50nm).

System

Wavelength (nm)

The wavelength of the laser used in the Zetasizer μ V instruments, or for the measurement. Either 632.8nm 'red' or 532nm 'green' laser wavelengths are available.

Scattering angle (degrees)

The angle at which the measurement will be performed - either 173°, or 90° for the 'classical' optics arrangement.

Toluene count rate (Kcounts)

The scattering count rate of the toluene reference.

Saving the Debye plot

The parameters and data inputted to produce the plot can be saved by pressing the **Save** button, and then reviewed at a later stage by pressing the **Load** button.

Copying the Debye plot

The graph can be pasted into another application (such as Microsoft Word or Excel) by selecting the **Copy** button.

Results area

With both the table data and sample parameters entered the results will be automatically calculated and shown alongside the graph. The results displayed are:

MW (kDa) - Molecular weight

Shows the measured weight of a molecule within the sample expressed in atomic mass units; indicated in kiloDaltons. It is calculated from the intercept of the KC/RoP vs concentration Debye plot.

+/-

The expected error in the Molecular weight, derived from the scatter in the data about the least squares best fit line.

% Error in MW

The error in the calculated Molecular weight arising from the use of only a single angle. For isotropic scattering particles (diameter < ~50nm), this error should be negligible.

A₂ (ml mol/g²) - Second virial coefficient

A property describing the interaction strength between the molecule and the solvent. This is calculated from the slope of the plot

K (Mol cm²/g)

The instrument optical constant, as defined in **Chapter 14**.

Molecular weight calculations

The hydrodynamic size measured by Dynamic Light Scattering (DLS) is defined as “the size of a hypothetical hard sphere that diffuses in the same fashion as that of the particle being measured”. In practice though, macromolecules in solution are non-spherical, dynamic (tumbling), and solvated. Because of this, the diameter calculated from the diffusional properties of the particle will be indicative of the apparent size of the dynamic hydrated/solvated particle. Hence the terminology, **‘Hydrodynamic’ diameter**.

If the **Molecular weight** (or mass) and the partial **Specific volume** (inverse density) for the particle being measured are known, then a mass equivalent spherical size can be calculated. The closer the particle is to being spherical, the closer the mass equivalent spherical diameter will be to the DLS measured hydrodynamic diameter. In fact, it is the difference in these two values, coupled with **Perrin** theory (below), that allows **particle shape** information to be extracted from DLS measurements.

Once the **Molecular weight** - either measured or estimated - and the **specific volume** are known, the **particle shape** information can be estimated by using the **Protein utilities** tool. The Shape estimate calculator takes the entered data and then applies two equations - the **Stokes-Einstein** and the **Perrin** factor.

Stokes-Einstein equation

The measured data in a DLS experiment is the correlation curve. Embodied within this curve is all of the information regarding the diffusion of particles within the sample that has been measured.

By fitting the correlation curve to an exponential function, the diffusion coefficient (D) can be calculated (D is proportional to the lifetime of the exponential decay).

With the diffusion coefficient (D) now known, the **Hydrodynamic diameter** can be calculated by using a variation of the Stokes-Einstein equation.

The **Stokes-Einstein** equation for the Hydrodynamic diameter is :
$$D_H = \frac{kT}{f} = \frac{kT}{3\pi\eta D}$$

- D_H : Hydrodynamic diameter.
- k : Boltzmann constant.
- f : Particle frictional coefficient.
- η : Solvent viscosity.
- T : Absolute temperature.
- D : Diffusion coefficient.

The Stokes-Einstein equation was developed using the assumption of hypothetical hard spheres.

Perrin factor

For non-spherical particles, the **Perrin** or shape factor (F) can be used to estimate particle shape.

The Perrin factor is used to calculate the prolate and oblate axial ratios for ellipsoids with the same Perrin factor value.

The Perrin factor is defined as the ratio of the frictional coefficient for a sphere with the same volume as the particle being measured, to the frictional coefficient for a sphere with the same mass as the particle being measured.

$$\text{The Perrin factor } (F) \text{ is : } F = \frac{f_{Vol}}{f_{Mass}} = \frac{6\pi\eta D_{Vol}}{6\pi\eta D_{Mass}} = \frac{D_{Vol}}{D_{Mass}} = \frac{D_H}{D_{Mass}}$$

- D_H : Hydrodynamic diameter. The diameter as measured via DLS.
- D_{Mass} : The diameter by mass. This is calculated from the known Molecular weight and the specific volume of the particle.
- f : Particle frictional coefficient.
- η : Solvent viscosity.
- T : Absolute temperature.

Shape estimate calculation

Enter the **Molecular Weight** result, **Specific Volume** and **Hydrodynamic Diameter** (measured using dynamic light scattering) into the appropriate text boxes.

The Perrin (shape) factor (F), plus the Prolate and Oblate axial ratio will be automatically calculated and displayed in the results area.

Shape Estimates

Input values	Results
Molecular Weight (kDa) <input style="width: 50px;" type="text" value="2"/>	Perrin Factor(F) <input style="width: 80px;" type="text" value="0.858"/>
Specific Volume(ml/g) <input style="width: 50px;" type="text" value="2"/>	Prolate Axial Ratio <input style="width: 80px;" type="text" value="-0.501"/>
Hydrodynamic Diameter(nm) <input style="width: 50px;" type="text" value="2"/>	Oblate Axial Ratio <input style="width: 80px;" type="text" value="-0.290"/>
<input type="checkbox"/> Subtract solvent layer (2.5Å)	

If required, a solvent layer can be subtracted from the hydrodynamic radius when calculating the Perrin factor. To do this select the **Subtract solvent layer** check box.

Molecular weight estimate

Whilst the preferred method of measuring absolute Molecular weight is by performing concentration dependent light scattering measurements, this can be very time consuming, from the point of view of the sample preparation. Providing that only an estimate of the Molecular weight is required then it can be derived by utilising a relationship between the Hydrodynamic radius and the molecule conformation.

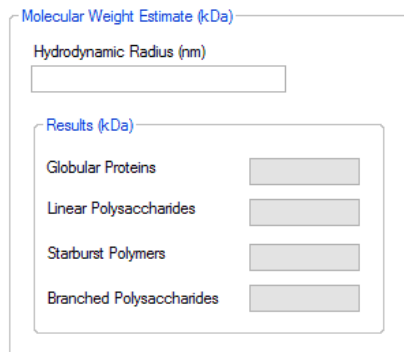

Molecular Weight Estimate (kDa)

Hydrodynamic Radius (nm)

Results (kDa)

Globular Proteins	<input type="text"/>
Linear Polysaccharides	<input type="text"/>
Starburst Polymers	<input type="text"/>
Branched Polysaccharides	<input type="text"/>

To find the Molecular weight estimate, enter the measured **Hydrodynamic radius** value into the text box and the estimated Molecular weight will automatically be calculated. The Molecular weight is displayed in four ways, which are representative of the four Molecular weight families:

**Globular
Proteins**

**Linear
polysaccharides**

**Branched
polysaccharides**

**Starburst
polymers**

Hydrodynamic radius estimate

This works in the same way as above, except the **Molecular weight** (in KDaltons) is entered to find the Hydrodynamic radius instead.

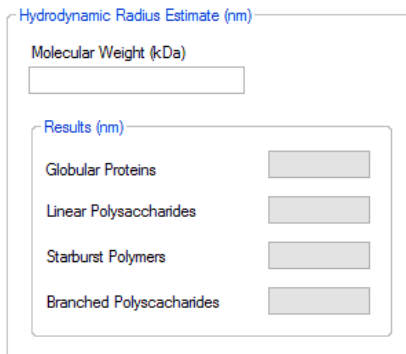

Hydrodynamic Radius Estimate (nm)

Molecular Weight (kDa)

Results (nm)

Globular Proteins	<input type="text"/>
Linear Polysaccharides	<input type="text"/>
Starburst Polymers	<input type="text"/>
Branched Polysaccharides	<input type="text"/>

Concentration utilities

Select the Concentration utilities tab to view concentration and scattering parameters.

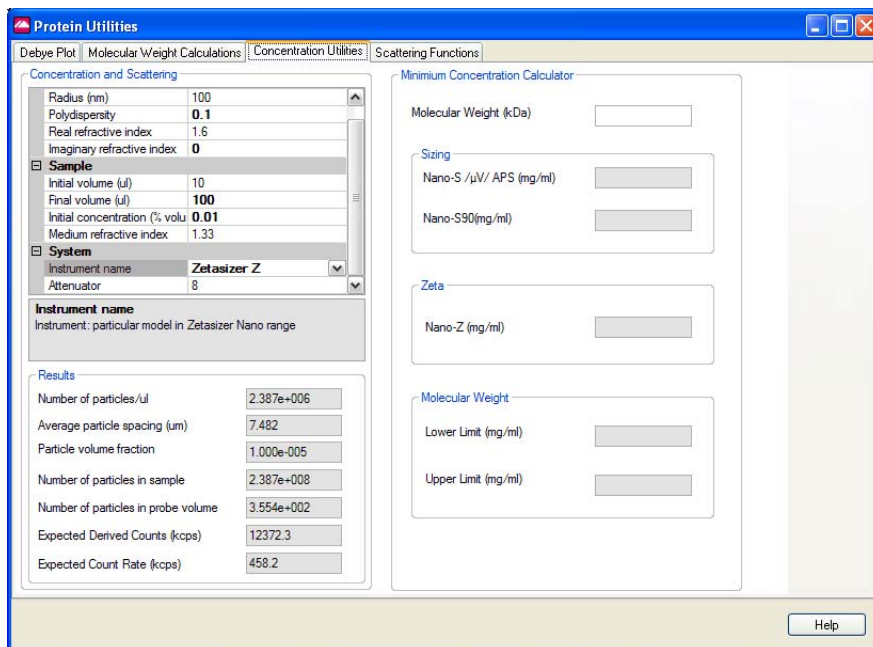

Concentration and Scattering

This area of the dialogue contains features to establish the concentration and scattering levels that may be observed from the sample.

Enter the values from the measurement into the table. On entering each value, press the return key afterwards and the results table will be updated.

The table can be displayed in a categorised view  or alphabetically .

Minimum Concentration Calculator

By entering only the Molecular weight the Sample concentration (mg/ml) values required for performing a measurement can be calculated.

Scattering functions

A scattering function plot can be generated by inputting the measurement data in the list on the right, in this dialogue:

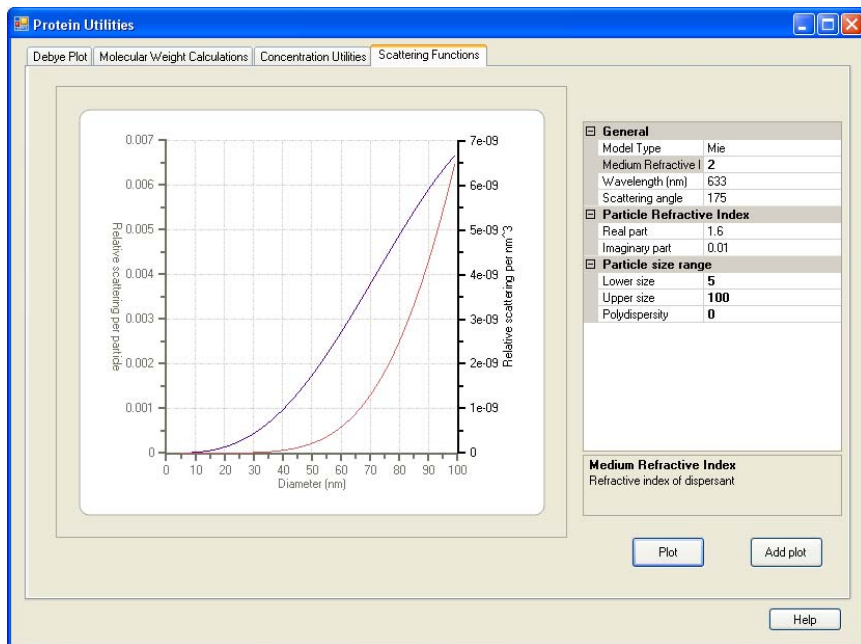

Enter the values from the measurement into the table and press **Plot** - the graph will update to show the values entered.

To see the result of changing a value, change the required value and press **Add plot** - a new plot line will be added to the graph.

Size theory

Introduction

The aim of this chapter is to describe the basic **Size** principles behind the Zetasizer μV . This will help in understanding the meaning of the results achieved.

The chapter is divided into two major sections. **What is Dynamic light scattering?** and **Operation of the Zetasizer μV - Size measurements**. The first section describes the theory, while the second describes the physical operation of how a size measurement is performed.

What is Dynamic Light Scattering?

The Zetasizer μV series performs size measurements using a process called **Dynamic Light Scattering (DLS)**.

Dynamic Light Scattering (also known as **PCS - Photon Correlation Spectroscopy**) measures **Brownian motion** and relates this to the size of the particles. It does this by illuminating the particles with a laser and analysing the intensity fluctuations in the scattered light.

Scattering intensity fluctuations

If a small particle is illuminated by a light source such as a laser, the particle will scatter the light in all directions.

If a screen is held close to the particle, the screen will be illuminated by the scattered light. Now consider replacing the single particle with thousands of stationary particles. The screen would now show a speckle pattern as shown alongside.

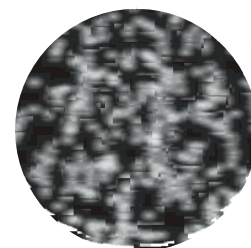

ill 7676

The speckle pattern will consist of areas of bright light and dark areas where no light is detected.

What causes these bright and dark areas? The diagram below shows the propagated waves from the light scattered by the particles. The bright areas of light are where the light scattered by the particles arrives at the screen with the same phase and interferes constructively to form a bright patch. The dark areas are where the phase additions are mutually destructive and cancel each other out.

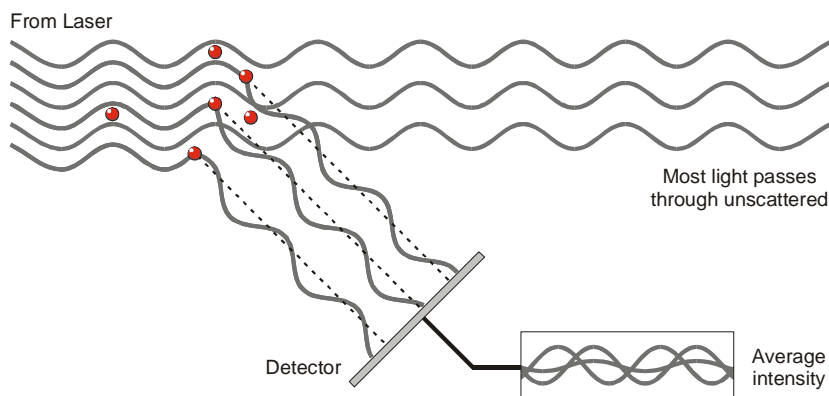

The scattered light falling on the detector.

In the above example we said that the particles are not moving. In this situation the speckle pattern will also be stationary - in terms of both speckle position and speckle size. iii 6091

In practice, particles suspended in a liquid are never stationary. The particles are constantly moving due to Brownian motion. Brownian motion is the movement of particles due to the random collision with the molecules of the liquid that surrounds the particle. An important feature of Brownian motion for DLS is that small particles move quickly and large particles move more slowly. The relationship between the size of a particle and its speed due to Brownian motion is defined in the **Stokes-Einstein** equation.

As the particles are constantly in motion the speckle pattern will also appear to move. As the particles move around, the constructive and destructive phase addition of the scattered light will cause the bright and dark areas to grow and diminish in intensity - or to put it another way, the intensity appears to fluctuate. The Zetasizer μ V system measures the rate of the intensity fluctuation and then uses this to calculate the size of the particles.

Interpreting scattering intensity fluctuation data

We know that the Zetasizer measures the fluctuation in scattering intensity and uses this to calculate the size of particles within the sample - but how does it do this?

Within the instrument is a component called a digital correlator. A correlator basically measures the degree of similarity between two signals over a period of time.

If we compared the intensity signal of a particular part of the speckle pattern at one point in time (say time = t) to the intensity signal a very short time later ($t + \delta t$) we would see that the two signals are very similar - or strongly correlated. If we then compared the original signal a little further ahead in time ($t + 2\delta t$), there would still be a relatively good comparison between the two signals, but it will not be as good as at $t + \delta t$. The correlation is therefore reducing with time.

Now consider the intensity of the signal at ' t ' with the intensity at a much later time - the two signals will have no relation to each other as the particles are moving in random directions (due to Brownian motion). In this situation it is said that there is no correlation between the two signals.

With DLS we are dealing with very small time scales. In a typical speckle pattern the length of time it takes for the correlation to reduce to zero is in the order of 1 to ten's of milliseconds. The "short time later" (δt) will be in the order of nanoseconds or microseconds!

If we compare the signal intensity at (t) with itself then we would have perfect correlation as the signals are identical. Perfect correlation is reported as 1 and no correlation is reported as 0.

If we continue to measure the correlation at ($t + 3\delta t$), ($t + 4\delta t$), ($t + 5\delta t$), ($t + 6\delta t$), etc, the correlation will eventually reach zero. A typical correlation function against time is shown below.

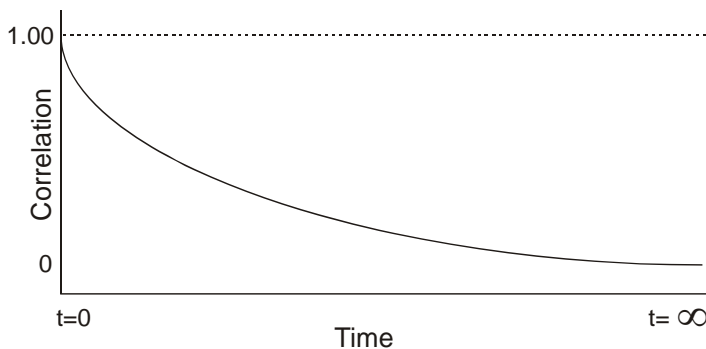

iil 6092

Using the correlation function

How does the correlation function relate to the Particle Size? We mentioned earlier that the speed of particles that are being moved by Brownian motion is related to the size of the particles (Stokes-Einstein equation). Large particles move slowly, while smaller particles move quickly. What effect will this have on the speckle pattern?

- If large particles are being measured, then, as they are moving slowly, the intensity of the speckle pattern will also fluctuate slowly.
- And similarly if small particles are being measured then, as they are moving quickly, the intensity of the speckle pattern will also fluctuate quickly.

The graph below shows the correlation function for large and small particles. As can be seen, the rate of decay for the correlation function is related to particle size as the rate of decay is much faster for small particles than it is for large.

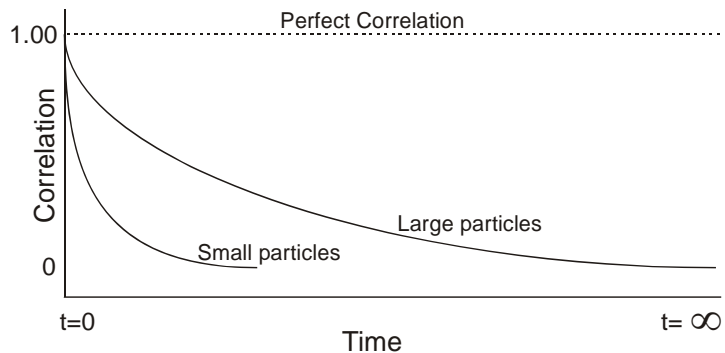

ill 6093

After the correlation function has been measured this information can then be used to calculate the size distribution. The Zetasizer software uses algorithms to extract the decay rates for a number of size classes to produce a size distribution.

A typical size distribution graph is shown below.

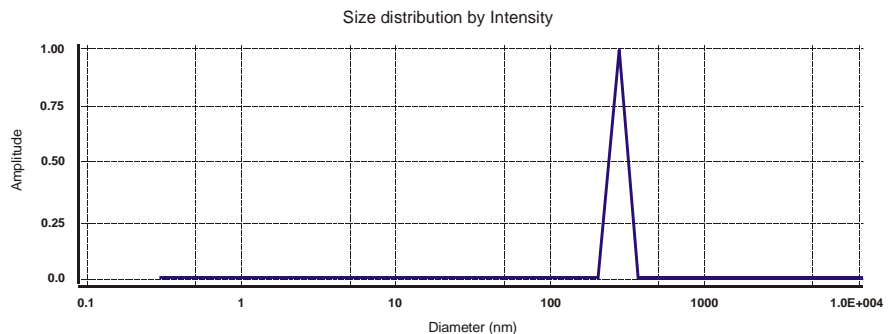

ill 6218

The X axis shows a distribution of size classes, while the Y axis shows the relative intensity of the scattered light. This is therefore known as an intensity distribution.

Although the fundamental size distribution generated by DLS is an intensity distribution, this can be converted, using Mie theory, to a volume distribution. This volume distribution can also be further converted to a number distribution. However, number distributions are of limited use as small errors in gathering data for the correlation function will lead to huge errors in distribution by number.

Intensity, volume and number distributions

What is the difference between intensity, volume and number distributions?

A very simple way of describing the difference is to consider a sample that contains only two sizes of particles (5nm and 50nm) but with equal numbers of each size particle.

The first graph below shows the result as a number distribution. As expected the two peaks are of the same size (1:1) as there are equal number of particles.

The second graph shows the result as a volume distribution. The area of the peak for the 50nm particles is 1000 times larger the peak for the 5nm (1:1000 ratio). This is because the volume of a 50nm particle is 1000 times larger that the 5nm particle (volume of a sphere is equal to $4/3\pi(r)^3$).

The third graph shows the result as an intensity distribution. The area of the peak for the 50nm particles is now 1,000,000 times larger than the peak for the 5nm (1:1000000 ratio). This is because large particles scatter much more light than small particles, the intensity of scattering of a particle is proportional to the sixth power of its diameter (from Rayleigh's approximation).

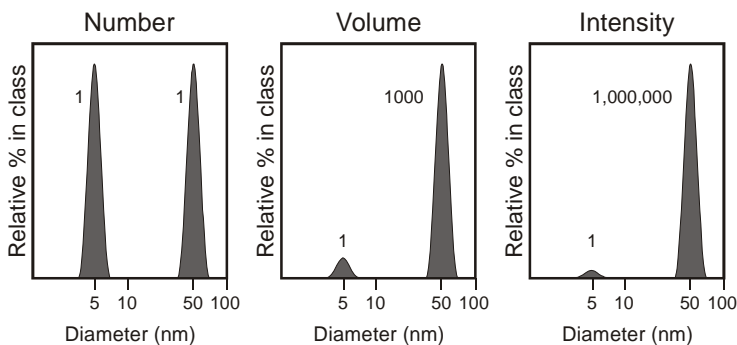

ill 6094

It is worth repeating that the basic distribution obtained from a DLS measurement is intensity - all other distributions are generated from this.

Operation of the Zetasizer μ V

- Size measurements

A typical DLS system comprises of six main components. First of all a **laser** ① is used to provide a light source to illuminate the sample particles within a **cell or measurement area** ②. Most of the laser beam passes straight through the sample, but some is scattered by the particles within the sample. A **detector** ③ is used to measure the intensity of the scattered light. As a particle scatters light in all directions, it is (in theory), possible to place the detector in any position and it will still detect the scattering.

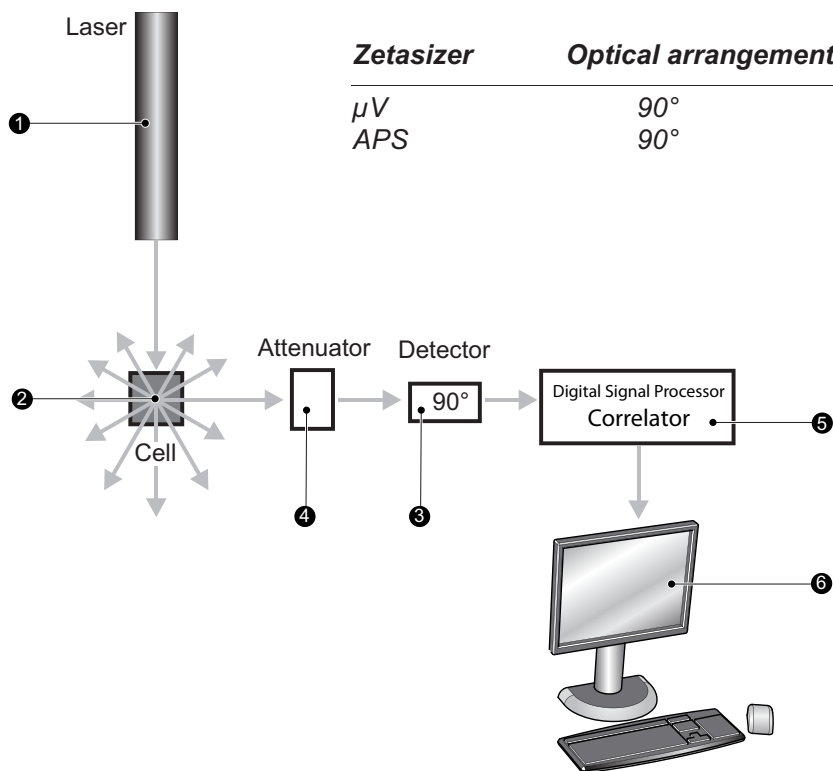

With the Zetasizer series, depending upon the particular model, the detector position will be at either 173° or 90°.

The intensity of the scattered light must be within a specific range for the detector to successfully measure it. If too much light is detected then the detector will

iii 8332

become overloaded. To overcome this an “**attenuator**” ④ is used to reduce the intensity of the laser and hence reduce the intensity of the scattering.

- For samples that do not scatter much light, such as very small particles or samples of low concentration, the amount of scattered light must be increased. In this situation, the attenuator will allow more laser light through to the sample.
- For samples that scatter more light, such as large particles or samples of higher concentration, the amount of scattered light must be decreased. This is achieved by using the attenuator to reduce the amount of laser light that passes through to the sample.

The appropriate attenuator position is automatically determined by the Zetasizer during the measurement sequence.

The scattering intensity signal for the detector is passed to a digital signal processing board called a **correlator** ⑤. The correlator compares the scattering intensity at successive time intervals to derive the rate at which the intensity is varying.

This correlator information is then passed to a **computer** ⑥, where the specialist Zetasizer software will analyse the data and derive size information.

Molecular Weight theory

Introduction

The aim of this chapter is to describe the basic **Molecular weight** principles behind the Zetasizer μV . This will help in understanding the meaning of the results achieved.

The chapter is divided into two major sections. **What is Static light scattering?** and **The Debye plot**. The first section describes the Molecular weight theory, while the second shows how a Molecular weight measurement is displayed.

What is Static light scattering?

The Zetasizer μV series performs Molecular weight measurements using a process called **Static Light Scattering (SLS)**. This is a non-invasive technique used to characterise the molecules in a solution.

In a similar way to Dynamic Light Scattering - the Size theory in **Chapter 13** - the particles in a sample are illuminated by a light source such as a laser, with the particles scattering the light in all directions. But, instead of measuring the time-dependent fluctuations in the scattering intensity, Static light scattering makes use of the time-averaged intensity of scattered light instead.

The intensity of light scattered over a period of time, say 10 to 30 seconds, is accumulated for a number of concentrations of the sample. This time averaging removes the inherent fluctuations in the signal, hence the term 'Static Light Scattering'.

From this we can determine the **Molecular weight (M_W)** and the **2nd Virial Coefficient (A_2)**.

The **2nd Virial Coefficient (A_2)** is a property describing the interaction strength between the particles and the solvent or appropriate dispersant medium.

- For samples where $A_2 > 0$, the particle 'likes' the solvent more than itself, and will tend to stay as a stable solution.
- When $A_2 < 0$, the particle 'likes' itself more than the solvent, and therefore may aggregate.
- When $A_2 = 0$, the particle-solvent interaction strength is equivalent to the molecule-molecule interaction strength – the solvent can then be described as being a **theta** solvent.

Static light scattering - theory

The Molecular weight is determined by measuring the sample at different concentrations and applying the **Rayleigh equation**. The Rayleigh equation describes the intensity of light scattered from a particle in solution.

The **Rayleigh equation** is

$$\frac{KC}{R_\theta} = \left(\frac{1}{M_w} + 2A_2C \right) P(\theta)$$

- R_θ : The Rayleigh ratio - the ratio of scattered light to incident light of the sample.
- M_w : Sample Molecular weight.
- A_2 : 2_{nd} Virial Coefficient.
- C : Concentration.
- P_θ : Angular dependence of the sample scattering intensity. Please refer to the Rayleigh scattering section.
- K : Optical constant as defined below.

$$K = \frac{4\pi^2}{\lambda_o^4 N_A} \left(n_o \frac{dn}{dc} \right)^2$$

N_A : Avogadro's constant.

λ_o : Laser wavelength.

n_o : Solvent refractive index.

dn/dc : The differential refractive index increment. This is the change in refractive index as a function of the change in concentration. For many sample/solvent combinations this may be available in literature; while for novel combinations the dn/dc can be measured by use of a differential refractometer.

The standard approach for Molecular weight measurements is to first measure the scattering intensity of the analyte used relative to that of a well described ‘standard’ pure liquid with a known Rayleigh ratio.

A **common standard** used in Static light scattering is **Toluene**, for the simple reason that the Rayleigh ratios of toluene are suitably high for precise measurements, are known over a range of wavelengths and temperatures and, maybe more importantly, Toluene is relatively easy to obtain. The Rayleigh ratio of Toluene can be found in many reference books, but for reference purposes the expression used to calculate the sample Rayleigh ratio from a toluene standard is given below.

$$R_{\theta} = \frac{I_A n_o^2}{I_T n_T^2} R_T$$

- I_A : Residual scattering intensity of the analyte (i.e. the sample intensity – solvent intensity).
- I_T : Toluene scattering intensity.
- n_o : Solvent refractive index.
- n_T : Toluene refractive index.
- R_T : Rayleigh ratio of toluene.

Rayleigh scattering

The P_{θ} term in the Rayleigh equation embodies the angular dependence of the sample scattering intensity. The angular dependence arises from constructive and destructive interference of light scattered from different positions on the same particle, as shown below.

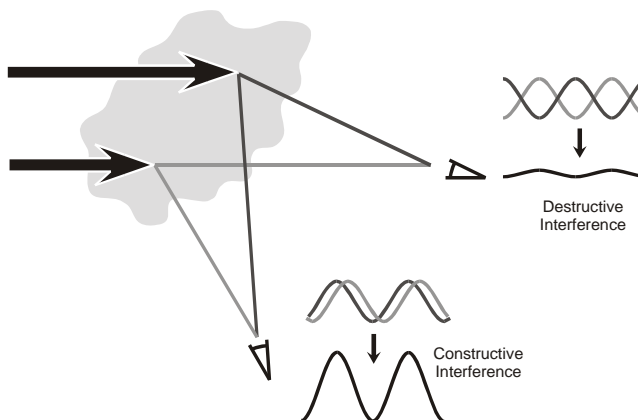

ill 6746

This phenomenon is known as **Mie scattering**, and it occurs when the particle size is of the same order as the wavelength.

However when the particles in solution are much smaller than the wavelength of the incident light, multiple photon scattering will be avoided. Under these conditions, P_0 will reduce to **1** and the angular dependence of the scattering intensity is lost. This type of scattering is known as **Rayleigh scattering**.

The Rayleigh equation will now be:

$$\frac{KC}{R_0} = \left(\frac{1}{M} + 2A_2C \right)$$

We can therefore stipulate that if the particle is small, Rayleigh scattering can be assumed and the Rayleigh approximation used.

With the Zetasizer μV series the applicable Molecular measurement weight range is from a few hundred g/mol to 500,000 for linear polymers, and over 20,000,000 for near spherical polymers and proteins.

The Debye plot

The intensity of scattered light that a particle produces is proportional to the product of the weight-average Molecular weight and the concentration of the particle.

The Zetasizer $\mu V S$ and ZS measure the **Intensity of scattered light** (KC/R_0) of various **concentrations** (C) of sample at **one** angle; this is compared with the scattering produced from a standard (i.e. Toluene).

The graphical representation of this is called a Debye plot and allows for the determination of both the Absolute Molecular Weight and 2nd Virial Coefficient.

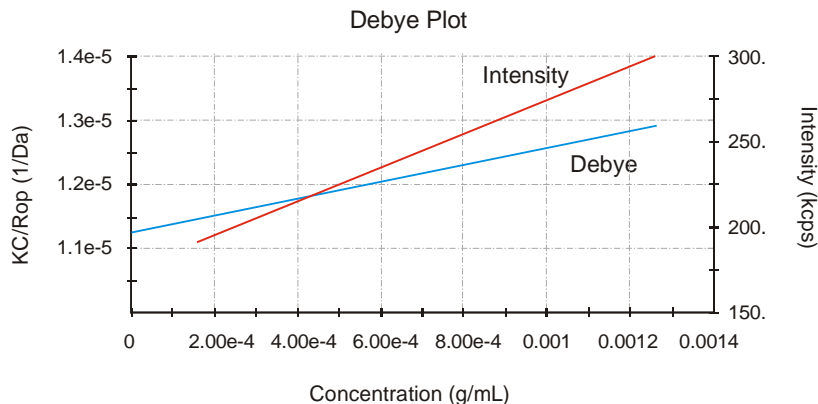

ill 7675

The weight-averaged Molecular weight (**Mw**) is determined from the intercept at zero concentration i.e. $\mathbf{KC/R_0 = 1/Mw}$ (for $c \rightarrow 0$) where the Mw is expressed in Daltons (or g/mol).

The **2nd Virial Coefficient (A_2)** is determined from the gradient of the Debye plot.

Each plot and Molecular weight measurement is performed by doing several individual measurements; from just the solvent used (a zero concentration measurement), through sample preparations of various concentrations.

The diagram below shows how the Molecular weight and 2nd Virial Coefficient are derived from the Debye plot.

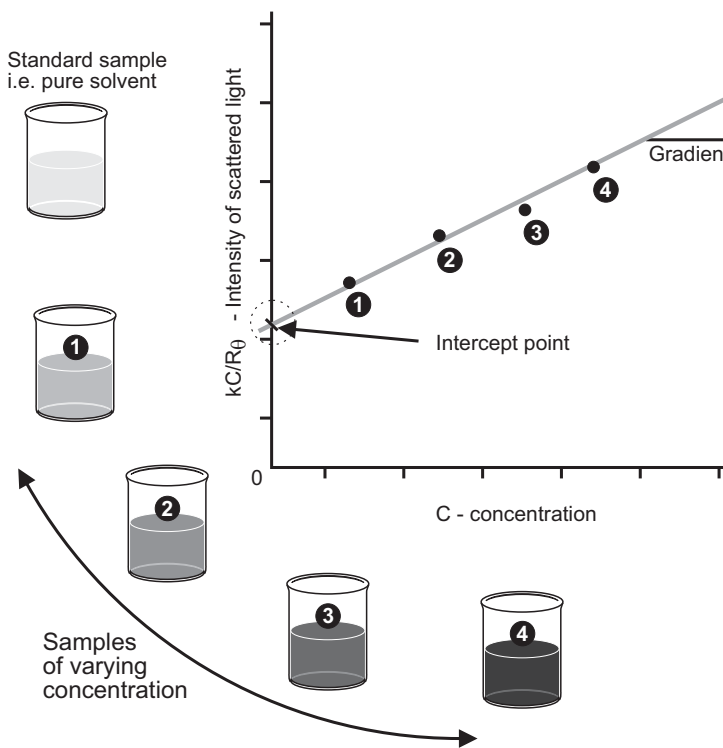

As only one measurement angle is used in this case, a plot of $\mathbf{KC/R_0}$ versus \mathbf{C} should give a straight line whose intercept at zero concentration will be $\mathbf{1/Mw}$ and whose **gradient** is proportional to $\mathbf{A_2}$.

ill 8208

Part 3 - Appendices

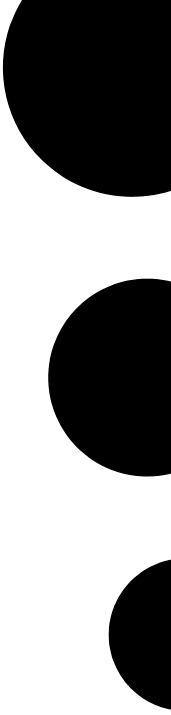

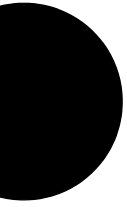
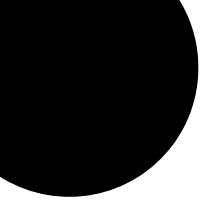

Specification

Specification

Parameter	Specification
Size range*	0.3nm to 0.5 microns
Molecular weight range*	380Da to > 20MDa
Minimum sample volume	2 μ L
Sensitivity at minimum volume	0.1mg/ml lysozyme
High concentration	Yes - optically clear samples
SEC detector mode	8 μ l flow cell
Laser	50mW, 830nm
Temperature range	2°C to 90°C \pm 0.1 °C
Weight	14kg
Dimensions	W:D:H, 350mm x 410mm x 170mm
Power	90V-260V AC, 50/60Hz, 100W
Dry air	100kPa (1bar), 4mm o.d. tubing
Computer interface	USB
Measurement technique	Dynamic light scattering (90 degrees)
Detector	Avalanche photodiode, Q.E. >50% at 830nm
Product laser class	Class 1 compliant, IEC 60825-1(1993)+A1(1997)+A2(2001)
Condensation control	Purge facility using dry air
Ambient operating conditions - Humidity	+10 to +35 °C (+50 to 95 °F) 10 to 90% (non-condensing)

Recommended computer specification

Contact the Malvern Helpdesk or website for the recommended computer specification, otherwise consult the Software Update Notification document supplied on the software CD.

* sample dependent

Chemical compatibility

Components of the Zetasizer μV that may come into contact with the sample are manufactured from materials that are considered to give the widest protection from chemical attack. However, it is important to check that any sample used is chemically compatible with the materials mentioned.



Warning!

It is advisable that the chemical compatibility is checked against the materials identified below before inserting a sample. It is also recommended that a test is performed on the material with the sample before more permanent usage is undertaken.

Cell area

As the sample measured is held within the cuvette or cell used, all components within the cell area will only come into contact with the sample if spillage occurs. The materials list below details all components that may come into contact if this occurs.

Component	Materials
Cell basin assembly (lid, basin and drain channel)	Polypropylene The outside of the cell basin and top of the cell lid is coated with a solvent resistant paint. This paint displays similar resistance properties to polypropylene. The inside of the cell basin and drain channel are not coated.
Drain tube	Tygon, F-4040-A
Electrodes	Gold plated beryllium/copper
Cell holder	Aluminium (anodised)

Cells and Cuvettes

Refer to the descriptions in **Chapter 4** for the materials used for each of the available cells.

Unpacking instructions

Appendix B of the Zetasizer μ V series User Manual MAN0425 Issue 3.1

Déballez l'instrument

Auspacken des Gerates

Desempaquetado del aparato

Desempacotamento do instrumento

1.

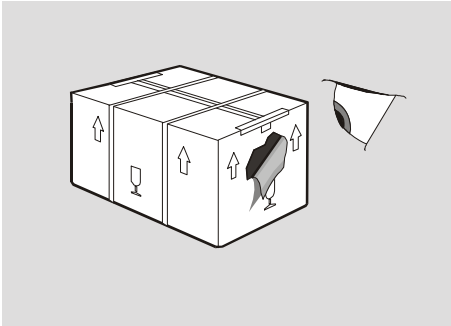

If there is any sign of damage contact the freight carrier immediately.

Si vous constatez des signes de dommages quelconques, contactez immédiatement le transporteur.

Bei irgendwelchen Zeichen von Transportschäden den Spediteur sofort benachrichtigen.

Si se advierte algún signo de deterioro, contactar inmediatamente con el transportista.

Contacte imediatamente a empresa transportadora se houver qualquer sinal de embalagem danificada.

2.

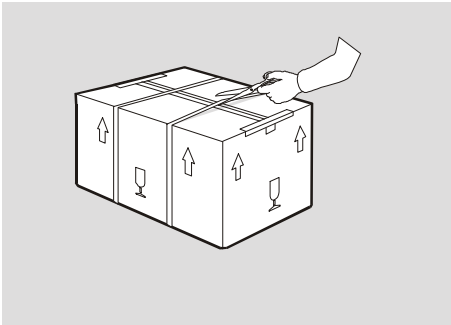

Cut through the plastic bonding straps.

Découpez les courroies d'attache en plastique.

Die Kunststoffbänder durchschneiden.

Cortar las tiras de sujeción de plástico del embalaje.

Corte as tiras plásticas que prendem o conjunto.

3.

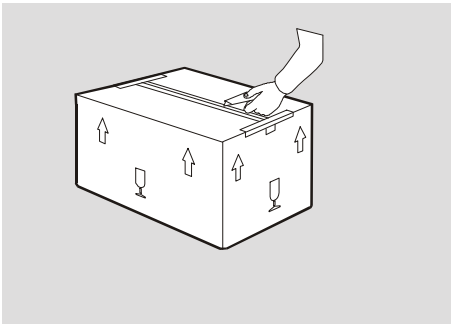

Carefully cut the plastic packing tape along the fold lines.

Découpez avec précaution le ruban d'emballage en plastique, le long des pliures.

Die Kunststoffverpackungsbänder vorsichtig entlang den Falzlinien durchschneiden.

Cortar con cuidado la cinta de embalaje de plástico por la líneas de doblado.

Com cuidado, corte a fita de embalagem plástica ao longo das dobras.

4.

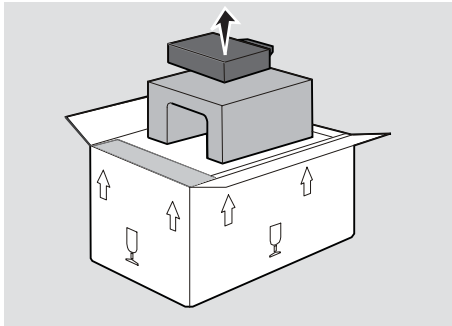

Open the wings of the carton and remove the top foam insert.

Ouvrez les rabats du carton et retirez les blocs de mousse du haut.

Die Klappen des Kartons öffnen und die oberen Schaumeinlagen entfernen.

Abrir los costados de la caja y extraer las piezas intercaladas de espuma de la parte superior.

Abra as abas da caixa e retire o enchimento de espuma que está em cima.

5.

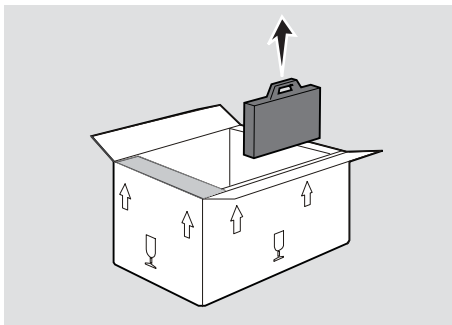

Remove all other packages from the carton and unwrap these.

Sortez tous les autres paquets du carton et déballez-les.

Sämtliche andere Pakete aus dem Karton nehmen und auspacken.

Retirar todos los demás paquetes de la caja y desenvolverlos.

Retire todas as outras embalagens da caixa e abra-as.

6.

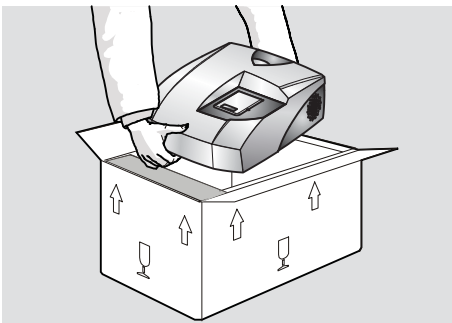

Lift the instrument out of the carton and place on the workbench.

Soulevez l'instrument pour le sortir du carton, et posez-le sur le banc.

Das Gerät aus dem Karton heben und auf der Werkbank aufstellen.

Levantar el aparato, sacarlo de la caja, y colocarlo sobre el banco de trabajo.

Tire o instrumento da caixa e coloque-o na bancada.

7.

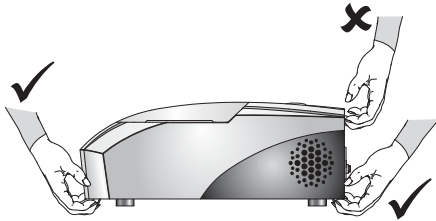
**Never lift the instrument by its covers.**

Pour soulever l'instrument, ne le tenez jamais par ses couvercles.

Niemals das Gerät an den Abdeckungen anheben.

No levantar nunca el aparato por sus cubiertas.

Nunca levante o instrumento pegando pelas suas tampas.

8.

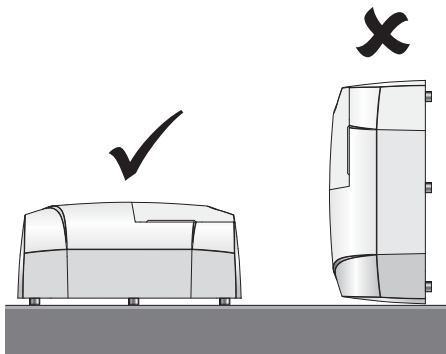
**Always place the instrument on its feet. Placing it on its side will damage the covers.**

Posez toujours l'instrument sur ses pieds. Si vous le posez sur le côté, vous endommagerez les couvercles.

Das Gerät stets auf seinen Füßen aufstellen. Ein seitliches Aufliegen beschädigt die Abdeckungen.

Se debe colocar siempre el aparato sobre sus patas.

Depositá-lo de costado dañaría las cubiertas.

Coloque sempre o instrumento na vertical, sobre os seus pés. Se o colocar de lado irá danificar as tampas.

9.

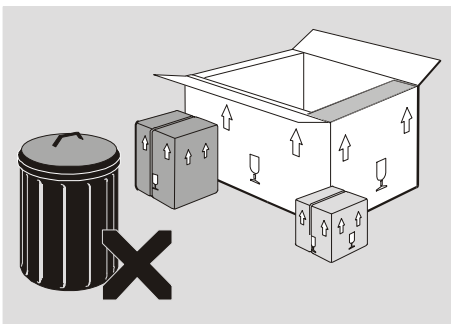
**Retain all packaging in case the instrument requires transporting in the future.**

Conservez tous les emballages, au cas où l'instrument devrait être transporté ultérieurement.

Das gesamte Verpackungsmaterial aufbewahren, falls in Zukunft ein weiterer Transport des Geräts erforderlich wird.

Conservar todo el material de embalaje por si el aparato debiera ser transportado en el futuro.

Guarde todo o material de embalagem, caso seja necessário no futuro transportar o instrumento.

Installation

Introduction

It should be noted that the Zetasizer μV system should initially be commissioned by Malvern trained personnel. This appendix will show how to re-install the system, typically required under the following circumstances:

- **Moving the instrument.**

Should it become necessary to move the system from one laboratory to another, read the information in this appendix to correctly reconnect the system.

- **Changing the computer.**

It may be company policy to periodically upgrade computers. Detail is given on actions required.

Only install the system in a suitable environment as detailed in the **Essentials Manual's** Environmental conditions section.



Warning!

Do not obstruct the ventilation slots underneath the instrument, nor the fans on the rear panel.

Installing the Zetasizer μ V

Installing the Zetasizer μ V is very simple.

► **To install the system:**

- Connect the USB cable to the connector marked **USB** on the rear panel of the Zetasizer μ V instrument. Connect the other end of the cable to the USB connection on the computer. ill 7905



Note

See **Chapter 3** for a detailed illustration of the rear panel.

-
- Connect the power cable to the power socket on the rear panel of the instrument.



Warning!

This product must be connected to a protective earth

-
- Make all computer connections (mouse, keyboard, power, etc) by following the instructions provided with your computer.

Installation options

- If purge air is required connect to the purge air port on the rear panel. Refer to the specification in **Appendix A**.

Changing the computer

If, at some point in the future, the computer used with the instrument is changed, the following actions will be required.

► **To install the system:**

1. Insert the **Zetasizer Software** CD into the CD drive.
2. If **Autorun** is enabled on the computer, the software will start to install automatically. Follow all on-screen instructions to complete the installation.
3. If Autorun is not enabled, select **Start-Run-Setup** and follow the on-screen instructions.

**Note**

If the software is subsequently updated with a new version, any custom reports, parameter settings, SOPs, etc will be preserved.

Regulatory Statements

Disposal of Electrical & Electronic Equipment

This regulation is applicable in the European Union and other European countries with separate collection systems.

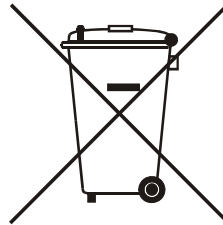

This symbol on the product or on its packaging indicates that when the last user wishes to discard this product it must not be treated as general waste. Instead it shall be handed over to the appropriate facility for the recovery and recycling of electrical and electronic equipment.

ill 7610

By not discarding this product along with other household-type waste, the volume of waste sent to incinerators or landfills will be reduced and natural resources will be conserved.

For more detailed information about recycling of this product, please contact your local city office, your waste disposal service, or your Malvern representative.



FCC Notice (US only)

The Federal Communications Commission (FCC) mark on this product signifies conformance to FCC regulations relating to Radio Frequency Devices. These have been satisfied by testing the product against, and being found to be compliant with: FCC CFR 47 Part 15:March 2003.Class A digital device.

The device complies with part 15 of the FCC Rules. Operation is subject to the following two conditions:

- 1) This device may not cause harmful interference, and
- 2) this device must accept any interference received, including interference that may cause undesired operation.

**Note**

This equipment has been tested and found to comply with the limits for a Class A digital device, pursuant to part 15 of the FCC rules. These limits are designed to provide reasonable protection against harmful interference when the equipment is operated in a commercial environment. This equipment generates, uses, and can radiate radio frequency energy and, if not installed and used in accordance with the instruction manual, may cause harmful interference to radio communications. Operation of this equipment in a residential area is likely to cause harmful interference in which case the user will be required to correct the interference at his own expense.

**Note**

Changes or modifications not expressly approved by Malvern Instruments Limited could void the user's authority to operate the equipment.

Canadian Regulatory Information

(This applies to Canada Only.)

This digital apparatus does not exceed the Class A limits for radio noise emissions from digital apparatus set out in the Radio Interference Regulations of the Canadian Department of Communications.

Note that Canadian Department of Communications (DOC) regulations provide, that changes or modifications not expressly approved by Malvern Instruments Limited could void your authority to operate this equipment.

This Class A digital apparatus complies with Canadian ICES-003.

Cet appareil numérique de la classe A est conforme à la norme NMB-003 du Canada.

VCCI acceptance (Japan only)

The Voluntary Control Council for Interference (VCCI) mark on this product signifies compliance to Japanese EMC regulations as specified by VCCI.

この装置は、情報処理装置等電波障害自主規制協議会（VCCI）の基準に基づくクラスA情報技術装置です。この装置を家庭環境で使用すると電波妨害を引き起こすことがあります。この場合には使用者が適切な対策を講ずるよう要求されることがあります。

III 6793

Translation:

This is a Class A product based on the standard of the Voluntary Control Council for Interference by Information Technology Equipment (VCCI). If this equipment is used in a domestic environment, radio disturbance may occur, in which case the user may be required to take corrective actions.

Index

Symbols

.dass 9-21
.del 8-8
.pag 8-2, 11-2
.sop 9-38
.sopl 3-19

Numerics

21 CFR Part 11 7-1, 10-11
21 CFR Part 11 icon 3-22
2nd Virial Coefficient 14-1, 14-4

A

A finished report 11-15
Absorption values 9-13
Access to the Instrument 1-3
Accessory button 4-14
Add workspace 8-3
Adding a group (security) 7-4
Adding a parameter 9-11
Adding a user (security) 7-5
Administrator account 7-2
Advanced (SOP) 9-6, 9-20, 9-29, 9-32
Advanced dialogue (SOP) 9-6
Advanced features 10-1
 Editing the result 10-10
 Expert Advice 10-25
 Exporting Results 10-12
 Flow-mode 10-16
 Options dialogue 10-21
 Result averaging 10-9
 Solvent Builder 10-2
 SOP Player 10-4
Ambient operating conditions A-1
Analysis mode 9-21
Analysis Model 9-21
Append to file 9-24
Appendices 1-2
Arguments 8-6, 10-15, 11-7
Atomic weights 2-3
Attenuator 6-5, 9-32, 13-7

Attenuator index 5-7
Audit trails 7-1
Automatic duration 9-29
Avogadro's constant 14-2

B

Baseline pointer 10-19
Batch print 3-12
Batch printing 8-8
Branched polysaccharides 12-9
Brownian motion 2-2, 13-1
Build option 1-5
Button bar 4-14

C

Calculation Editor 11-8
Calculation in report 11-7
Canadian Regulatory Information D-3
Cell
 Advice 4-3
 Choosing 4-3
 Cleaning 4-7
 Filling 4-7
Cell (SOP) 9-6
Cell area 3-8, 3-9
Cell basin 3-9
Cells 1-4, 3-10
Changing the computer C-1, C-2
Chemical compatibility 3-8
Chromatogram summary 10-20
Chromatographic column 10-16
Chromatography detector 10-16
Complex solvent 9-13, 10-2
 Building a... 10-3
Computer C-1
 Changing C-2
Concentration 6-3, 12-10
 Small particles 6-2
Concentration utilities 12-2, 12-10
Configure button 9-21
Control Palette (reports) 11-4

Correlation function 13-4

 Molecular weight 4-18

 Size 4-17

Correlator 13-7

Count rate

 Molecular weight 4-18

 Size 4-16

Count Rate Meter 3-16

Count rate meter 6-4

Count rate monitor 6-4

Covers 1-3

Create Average Result 3-13, 10-9

Create PDF 3-12

Creating an SOP 9-1, 9-8

Cumulants mean 5-7

Custom parameters 9-11

Cuvettes 1-4, 3-10, 4-4

D

Data export templates 3-16, 10-12

Data Processing - Export (SOP) 9-24, 9-32

Data Processing - Reports (SOP) 9-23, 9-32

Data Processing (SOP) 9-6, 9-20, 9-32

Debye

 Molecular weight 4-18

Debye plot 6-3, 12-1, 12-2, 14-4

Delay volume 9-33

Denaturation 9-35, 9-36

Detector type A-1

Dispersant Manager 9-13

Display range 9-22

Display the following...after... 9-19

Display the following...before... 9-19

Disposable cuvettes 3-10, 4-4

Disposable low volume polystyrene cuvette 4-5

Disposal of Electrical & Electronic Equipment D-1

Distributing an SOP 9-38

DLS 2-2, 13-1

Dn/Dc 5-12

dn/dc 12-5

Drag and Drop exporting 10-12

Dry-air supply 3-7

Dust filtration algorithm 6-4

Dynamic Light Scattering 2-2, 13-1

E

Edit result 3-13

Editing a group (security) 7-4

Editing a result 10-11

Editing a user (security) 7-5

Editing the result 10-10

Electrode voltage interlock 3-9

Engineering 3-16

Equilibration time 9-16

Equipment disposal D-1

European Commission Directives D-2

Existing SOP 9-2

Expert Advice 3-14, 4-15, 10-25

Expert Advice Tab 4-17, 4-18

 Flow-mode 4-19

Export 3-12

Export (SOP) 9-7, 9-24, 9-32

Export results 9-24

Export template 9-24, 10-14

Export to Clipboard 10-13

Exporting

 Parameters tab 10-13

 Settings tab 10-14

Exporting Results 10-12

External Inputs 3-17, 9-33

Extract SOP 3-13, 9-2, 9-3

Extracting an SOP 9-1, 9-37

F

FCC Notice D-2

Feature key 3-17, 7-1

Feature key (Options dialogue) 10-23

Federal Communications Commission D-3

File

 Creating 4-11

 Opening 4-11

File menu 3-12

Filling the cell 4-7

Filters 6-2

Filtration 6-2

Firmware version 1-1

Flow rate 9-34

Flow settings (SOP) 9-34

Flow-mode 9-33, 10-16

Flow-mode (Editing) 10-11, 10-17

Flow-mode (Inspecting) 10-17

Flow-mode measurements 4-18

Flow-mode measurements - Standard report 5-14

Flow-mode plot 10-17

Flow-mode SOPs 9-33

Folders 3-17
Folders (Options dialogue) 10-22
Folders toolbar 3-19
Frames in reports 11-7
Fundamental parameters 2-1

G

General notes 4-12
General options (SOP) 9-5, 9-15, 9-27
General Purpose 9-21
Glass - round aperture cuvette 4-5
Glass - square aperture cuvette 4-5
Glass cuvettes 3-10
Globular Proteins 12-9
Graph 5-8
 Control properties 5-8
Graphs in reports 11-9
Group name 7-4
Group properties 7-4

H

Hardware 3-5
Help desk 1-5
Help file 1-4, 4-14
Help menu 3-18
Help Topics 3-18
Humidity A-1
Hydrodynamic diameter 12-1, 12-7
 Estimate 12-9
Hydrodynamic radius 12-5

I

Icon
 21 CFR Part 11 3-22
 μ V 3-21
Initialisation routine 4-2
Installation C-1
Instructions (SOP) 9-6, 9-19, 9-29
Instrument
 Access 1-3
 Lifting B-4
 Moving C-1
 Specification A-1
Instrument Sub-menu 3-16
Instrument type 10-24
Intensity
 Size 4-17
Intensity distributions 13-5

Intensity PSD
 Molecular weight 4-18
 Size 4-17
Intercept 5-8
Interlock
 Laser safety 3-9

K

KC/Rq 14-4

L

Laser class A-1
Laser safety 3-9
Lid 3-9
Lifting the instrument B-4
Linear polysaccharides 12-9
Load Analysis settings... 9-21
Log sheet 4-15, 4-17, 4-18, 4-20
Log sheet Tab
 Flow-mode 4-19
Low volume cell
 Filling 4-8
Low volume Glass flow cuvette 4-6
Low volume quartz cuvette 4-4, 4-5

M

Macros 3-16, 3-17
Macros (Options dialogue) 10-22
Mains power input 3-6
Making a measurement 3-2, 4-2
Malvern logo 3-22
Malvern personnel 1-3
Malvern Website 1-5
Manual measurement 3-2, 4-1, 4-13
Mark-Houwink 9-15
Marquee 11-4
Material (SOP) 9-5, 9-12, 9-25
Materials Manager 9-12
Measure menu 3-15
Measure-Manual 3-3, 4-13
Measurement 3-17
 range 2-1
Measurement - Advanced (SOP) 9-20, 9-29
Measurement - Instructions (SOP) 9-19, 9-29
Measurement (Options dialogue) 10-23
Measurement (SOP) 9-6, 9-17, 9-28, 9-34
Measurement display 3-3, 3-21, 4-13
Measurement Duration 9-17, 9-31, 9-34

Measurement file window 3-19, 8-1
Measurement position 5-7, 9-20, 9-32
Measurement records 3-20
Measurement sequence 4-20
 Molecular weight 4-20
 Size measurements 4-20
Measurement tab 10-19
Measurement technique A-1
Measurement type (SOP) 9-5, 9-9
Measurements 9-18
Melting point 5-16
Melting point measurements 9-36
Melting point records 5-2
Melting point SOPs 9-35
Menu bar 3-12
Menu commands 1-4
Menus
 Edit 3-13
 File 3-12
 Help 3-18
 Measure 3-15
 Security 3-17
 Tools 3-16
 View 3-14
 Window 3-18
Mie scattering 14-4
Minimum Concentration Calculator 12-10
Model number 1-1, 1-5, 3-8
Modifying an SOP 9-1, 9-38
Molecular weight 2-1, 2-3
 Calculations 12-7
 Estimate 12-9
 Theory 14-1
 What is... 2-3
Molecular weight by Static Light Scattering 9-27
Molecular weight calculations 12-1
Molecular weight measurements - standard
 report 5-12
Molecular weight range A-1
Molecular weight SOPs 9-25
Moving the instrument C-1
Multiple Narrow Modes 9-21
Multi-view Tab 4-15, 4-17, 4-18
 Flow-mode 4-19

N

Naming convention 1-3
Navigation 8-8

Navigation toolbar 3-19
New SOP 9-2
Number distributions 13-5
Number PSD
 Molecular weight 4-18
 Size 4-17

O

Operator 1-3
Operators guide 1-2
Optical unit 3-6
Options 3-17
Options dialogue 10-21

P

Packaging B-4
Page Layout (reports) 11-2
Parameter
 Adding a... 9-11
Parameter icon 5-4
Parameters in reports 11-6
Partial Results 9-18, 9-31
Particle size 2-1
Password 7-5
 Changing the... 7-6
 Options 7-6
Passwords on reports 11-16
Pause (SOP Player) 10-8
PCS 13-1
Peak means 5-8
Peaks 10-18
Peaks tab 10-20
Perform size measurement 9-31
Permissions 3-17, 7-1, 7-5
Perrin factor 12-8
Photon Correlation Spectroscopy 13-1
Pictures in reports 11-6
Playlist 9-2, 10-4
Polydispersity 5-7
Power input socket 3-6
Power switch 3-7
Preparing the sample - Molecular weight 6-2
Preparing the sample - Size 6-1
Progress meter 4-15, 4-20
Protecting a report 11-16
Protein Analysis 9-21
Protein melting point 2-1
Protein utilities 3-16, 12-1

Q

Quartz cuvettes 3-10

R

Rayleigh equation 14-2

Rayleigh ratio 9-27

Rayleigh scattering 14-3

Rear Panel 3-6

Record type filter 8-4

Record view 3-3, 3-20, 5-1, 8-2, 8-5

Record view parameters 8-4

Records 5-1

 Moving and deleting 8-8

Refractive index 9-13, 12-5

Regulatory Statements D-1

Remote support 1-5

Report

 Adding elements to 11-4

 Creating 11-3

 Flow-mode measurements 5-14

 Molecular weight measurements 5-12

 Opening 11-3

 Protecting 11-16

 Saving 11-14

 Setting up elements 11-5

 Size measurements 5-6

 Trend measurements 5-16

Report Designer 3-20

 Introduction 11-1

 Opening 11-3

Report tabs 3-20, 5-4, 8-2, 8-7

Reports 5-1

Reports (SOP) 9-6, 9-23, 9-32

Result averaging 10-9

Result tab

 Flow-mode 4-18

 Molecular weight 4-18

 Size 4-15

Results 5-7

Run duration 9-29

S

Sample - Dispersant (SOP) 9-13

Sample - General Options (SOP) 9-27

Sample - General options (SOP) 9-15

Sample - Material (SOP) 9-12

Sample - Solvent (SOP) 9-25

Sample - Standard (SOP) 9-26

Sample - Temperature (SOP) 9-16, 9-28

Sample (Size) 9-10

Sample (SOP) 9-5

Sample concentration 6-1

Sample name 9-10

Sample preparation 4-3, 6-1, 6-2

Sample viscosity options 9-15

Scattering 12-10

Scattering functions 12-2

Scattering intensity fluctuations 13-1

Screen Layout (reports) 11-2

Second virial coefficient 5-13, 12-6

Security 7-1

 Configuration 7-3

 Configure Security 7-2

 Enabling 7-3

 Login 7-3

Security menu 3-17

Selecting a report 8-7

Selecting elements in reports 11-13

Sequence (SOP) 9-7, 9-36

Serial number 1-1, 1-5, 3-8, 11-16

Service engineer 1-3, 3-16

Settings sub-menu 3-16

Shape 12-1

Shape correction model 9-29

Shape estimate calculation 12-8

Shape model 5-12, 12-5

Size

 What is... 2-2

Size Measurement - Advanced (SOP) 9-32

Size measurement (SOP) 9-31, 9-37

Size measurements

 Operation 13-6

Size measurements - standard report 5-6

Size quality report 5-10

Size range

 Molecular weight 2-1

 Size 2-1, A-1

Size SOPs 9-10

Size theory 13-1

SLS measurement duration 9-28

Software

 Overview 3-11

 Starting 4-3

Software version 1-1, 1-5

Solvent (SOP) 9-5, 9-25

- Solvent builder 9-13, 10-2
- Solvents Manager 9-26
- SOP 2-1, 3-2, 4-1, 9-1
 - Creating an... 9-1, 9-8
 - Distributing an... 9-38
 - Existing 9-2
 - Extracting an... 9-1, 9-3, 9-37
 - Modifying an... 9-1, 9-38
 - New 9-2
 - SOP Player 10-4
 - Toolbar 9-3
 - Tree menu 9-4
- SOP dialogues
 - Data Processing 9-6
 - Data Processing - Export 9-7
 - Data Processing - Export (Molecular weight) 9-32
 - Data Processing - Export (Size) 9-24
 - Data Processing - Reports 9-6
 - Data Processing - Reports (Molecular weight) 9-32
 - Data Processing - Reports (Size) 9-23
 - Data Processing (Molecular weight) 9-32
 - Data Processing (Size) 9-20
 - Flow settings (Flow-mode) 9-34
 - Measurement 9-6
 - Measurement - Advanced 9-6
 - Measurement - Advanced (Molecular weight) 9-29
 - Measurement - Advanced (Size) 9-20
 - Measurement - Instructions 9-6
 - Measurement - Instructions (Molecular weight) 9-29
 - Measurement - Instructions (Size) 9-19
 - Measurement (Flow-mode) 9-34
 - Measurement (Molecular weight) 9-28
 - Measurement (Size) 9-17
 - Measurement type 9-4, 9-5, 9-9
 - Sample 9-5
 - Sample - Cell 9-6
 - Sample - Dispersant (Size) 9-13
 - Sample - Dispersant / Solvent 9-5
 - Sample - General Options 9-5
 - Sample - General Options (Molecular weight) 9-27
 - Sample - General Options (Size) 9-15
 - Sample - Material 9-5
 - Sample - Material (Molecular weight) 9-25
 - Sample - Material (Size) 9-12
 - Sample - Solvent (Molecular weight) 9-25
 - Sample - Standard 9-5
 - Sample - Standard (Molecular weight) 9-26
 - Sample - Temperature 9-6
 - Sample - Temperature (Molecular weight) 9-28
 - Sample - Temperature (Size) 9-16
 - Sample (Molecular weight) 9-25
 - Sample (Size) 9-10
 - Size Measurement - Advanced (Molecular weight) 9-32
 - Size Measurement (Molecular weight) 9-31
 - Size Measurement (Trend) 9-37
 - Trend - Sequence 9-7
 - Trend - Sequence (Trend) 9-36
- SOP Editor 9-3, 9-8
- SOP measurement 4-1, 4-11
 - Starting an... 4-12
- SOP Player 3-15, 3-19, 9-2, 10-4
- SOP Toolbar 3-19, 9-2, 9-8
- SOP Toolbar browser 9-2
- SOPs
 - Flow-mode 9-33
 - Melting point 9-35
 - Molecular weight 9-25
 - Size 9-10
 - Trend 9-35
- Sorting records 8-8
- Specification A-1, B-1
- Standard (SOP) 9-5, 9-26
- Standard Operating Procedures 2-1
- Standard toolbar 3-19
- Standards Manager 9-27
- Starburst polymers 12-9
- Start SOP 4-12
- Starting the measurement 4-14
- Startup 10-22
- Static light scattering 14-1
- Statistical deviation 9-30
- Statistics bar 3-14, 3-20, 5-3
- Status bar 3-14, 3-21, 4-14
- Status icons 3-21
- Stokes-Einstein equation 12-7, 13-2
- Stopping the measurement 4-14
- Summary 8-3
- Summary workspace 5-1
- Supervisor 1-3
- Supervisors guide 1-2

Systematic deviation 9-30

T

Tab views 4-15

Tables in reports 11-11

Temperature (SOP) 9-6, 9-16, 9-28

Text in reports 11-5

Theory

 Molecular weight 14-1

 Sizing 13-1

Tip of the day 3-18

Title bar 3-20

Toluene 14-3

Toolbars 3-14, 3-19

Tools 10-18

Tools menu 3-16

Traces 10-17

Traces tab 10-19

Tree menu (SOP) 9-4

Trend - Sequence (SOP) 9-36

Trend (SOP) 9-7

Trend measurements 2-1, 4-19

Trend measurements - Standard report 5-16

Trend SOPs 9-35

Turning on 4-2

U

Ultrasonics 6-2

Units conversion 3-22, 5-3, 5-5

Unpacking instructions B-1

USB cable C-2

User groups 7-1, 7-4

Username 7-5

Users (security) 7-5

V

Variation factors 9-30

VCCI acceptance D-3

View menu 3-14

Viewing a report 11-15

Viewing tools 10-18

Volume distributions 13-5

Volume PSD

 Molecular weight 4-18

 Size 4-17

Voluntary Control Council for Interference D-4

W

Website 1-5

Window menu 3-18

Workspace settings 5-1, 8-3

Workspace toolbar 3-19

Workspaces 3-14, 3-17, 8-1, 8-3

 Creating 8-3

 Deleting 8-5

 Displaying 8-3

 Exporting 8-5

 Importing 8-5

 Measurement files 3-20

 Modifying 8-4

www.Malvern.com 1-5

Z

Z-average mean 10-17

Z-average Size 5-7

Zetasizer model number 1-1

